

## Rod Locks RLSS Series

Nexen's new generation of linear holding/locking devices take rod locking technology to the next level. With superior performance, these spring-engaged, air-released units supplement air cylinders and guide rods for holding in power-off/e-stop situations. High clamping forces ensure positive holding with minimal air required for release. Choose from our standard products, or we will work with you to meet your unique application specifications.



### Precision Operation Maintains Accurate Positioning

The RLSS series of Rod Locks guarantees accurate positioning and provides precision holding while other operations are performed. The Rod Lock engages without causing any rod displacement, and also features extremely low backlash making them ideal for precision applications.

### Large Clamping Surface Ensures Consistent Performance

The RLSS line is designed with a large clamping surface that provides uniform force to the rod contact area on every engagement. The clamping mechanism utilizes numerous ball bearing to reduce friction.

### Spring-engaged Units Engage in Power-off Situations

Nexen's Rod Locks are spring-engaged, so they operate even in power-off situations to promote safety for operators and machinery. Multiple springs ensure reliable performance and redundancy. The fast response time of these spring-engaged products also increases positioning accuracy. Nexen's Rod Locks also feature locking mode sensing capability that allows engagement/disengagement feedback with the use of an optional inductive sensor.

### Sealed to Withstand Harsh Environments

Every RLSS Rod Lock is sealed to protect internal components. These seals are designed to withstand even harsh wash-down environments and are IP67 rated (anodized models exceed NEMA 4X rating). Consult Nexen for use in wash-down of humid environment applications. Rod Locks are available in natural brushed aluminum or with a black anodized coating.

### Manual Release

The cam operated manual release feature mechanically disengages the rod lock with the simple turn of a hex screw using a standard wrench. The default-to-lock function springs back to the engaged position when released.



**NEXEN'S STATIC ROD LOCKS** deliver precision holding with virtually no backlash, providing high accuracy in demanding applications. These spring-engaged, air-released units come in both ISO and NFPA sizes and will accept standard accessories.

The Rod Lock's large clamping surface ensures high clamping/holding force and Nexen offers models for use on a pneumatic cylinder or as a stand-alone unit on a guide rod. Customers can further increase holding forces by stacking multiple Rod Locks together. The patent pending design is sealed and features a natural brushed aluminum finish or a corrosion-resistant, anodized finish. Whatever your application, precision operation with hassle-free performance come standard with each compact unit.

## APPLICATIONS >>>

- MACHINE TOOLS
- HYDRAULIC PRESSES
- SCISSOR-LIFT TABLES
- POSITIONING EQUIPMENT
- AMUSEMENT RIDE EQUIPMENT
- PRINTING & PAPER HANDLING EQUIPMENT
- THEATRICAL EQUIPMENT (PLATFORMS)
- INJECTION MOLDING MACHINES
- AUTOMATION EQUIPMENT
- ELEVATORS AND LIFTS
- MINING APPLICATIONS

## UNDERSTANDING ROD LOCK NOMENCLATURE

The diagram below explains the components of a Rod Lock model number. In this example, the Nexen Rod Lock listed is a cylinder mounted, spring-engaged, black anodized, static rod lock for a two inch cylinder with a one inch rod.

RLSSB-200-100-C-A-MR

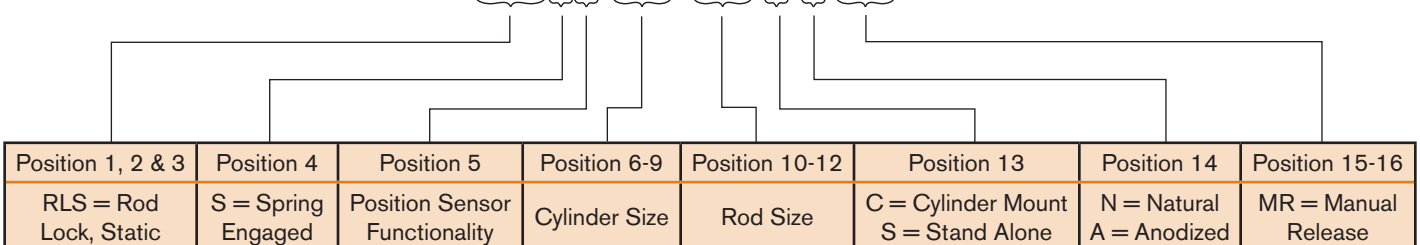

## ROD LOCK CUTAWAY (WITH MANUAL RELEASE)

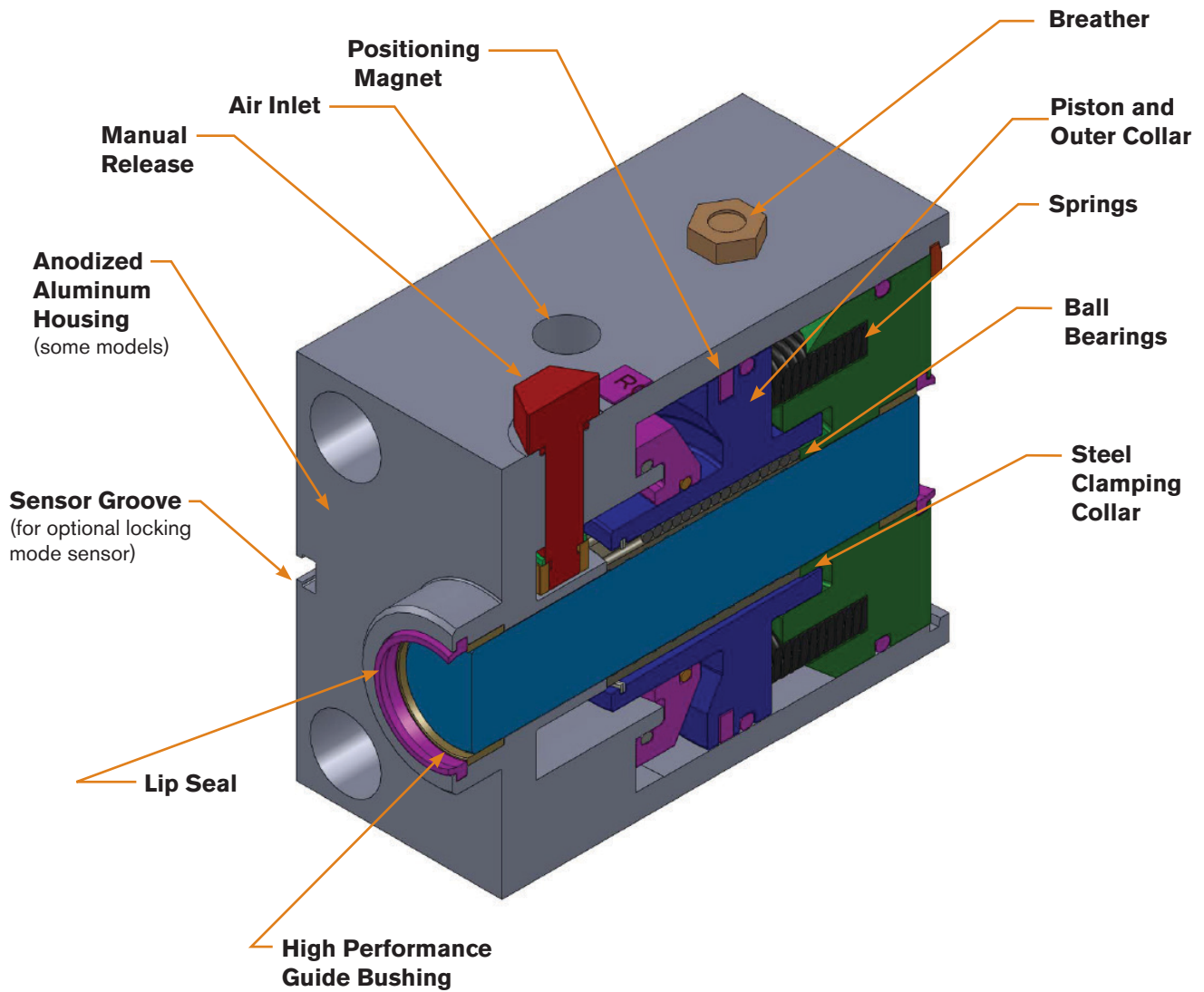

### FEATURES

- No Rod Displacement on Engagement
- Large Clamping Surface
- IP67 Rated [exceeds NEMA 4X]
- Fast Response Time
- Extremely Low Backlash
- Spring-Engaged Units
- Profile Matches Cylinder
- 4 bar [60 psi] Release Pressure
- Manual Release
- Sensor (Optional)

### BENEFITS

- Maintains Accurate Positioning
- Consistent Clamping Force
- Suitable for Wash-Down Areas (Consult Nexen)
- High Cycle Rates, Accuracy
- Precision Holding
- Holds Load During Power/Pressure Loss
- Compact Unit, Easy Integration
- Broad Application
- Release Without Air Pressure
- Detects Locking Mode

# STAND-ALONE Rod Locks FOR GUIDE ROD APPLICATIONS

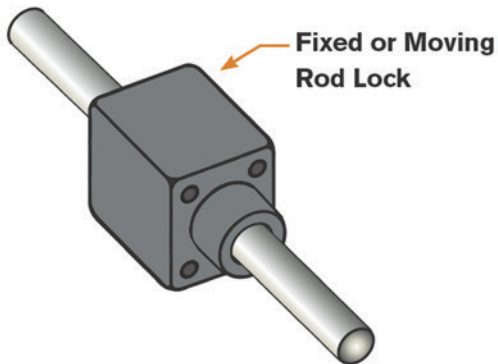

**ROUND GUIDE ROD APPLICATION**

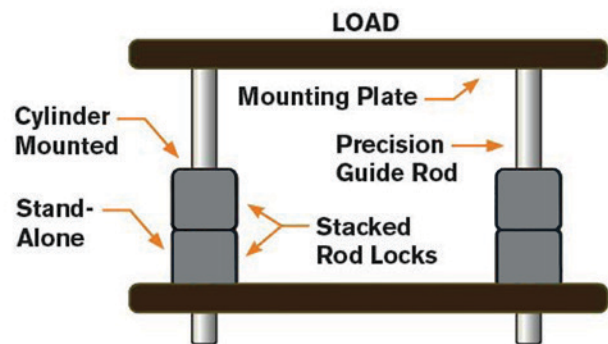

## STAND-ALONE ROD LOCK SPECIFICATIONS

### Inch Rod Locks

Rod Diameter	Model	Holding Force	Anodized P/N	Natural Finish P/N
0.625 in	RLSSB 150-063-S	180 lbs	966221	966220
0.625 in	RLSSB 200-063-S	314 lbs	966228	966227
0.625 in	RLSSB 250-063-S	491 lbs	966242	966241
1.000 in	RLSSB 200-100-S	250 lbs	966235	966234
1.000 in	RLSSB 325-100-S	830 lbs	966249	966248
1.000 in	RLSSB 400-100-S	1256 lbs	966256	966255
1.000 in	RLSSB 500-100-S	1963 lbs	966270	966269
1.375 in	RLSSB 400-138-S	1256 lbs	966263	966262
1.375 in	RLSSB 500-138-S	1963 lbs	966277	966276
1.375 in	RLSSB 600-138-S	2830 lbs	966284	966176

### Metric Rod Locks

Rod Diameter	Model	Holding Force	Anodized P/N	Natural Finish P/N
12 mm	RLSSB 032-012-S	800 N	966088	966068
16 mm	RLSSB 040-016-S	890 N	966089	966069
20 mm	RLSSB 050-020-S	1400 N	966090	966070
20 mm	RLSSB 063-020-S	2225 N	966091	966071
25 mm	RLSSB 080-025-S	3560 N	966092	966072
25 mm	RLSSB 100-025-S	5500 N	966093	966073
32 mm	RLSSB 125-032-S	8560 N	966094	966074

### Locking Mode Sensors

Sinking (NPN) Normally Open	966190
Sourcing (PNP) Normally Open	966195

# CYLINDER MOUNTED Rod Locks



Nexen's cylinder mounted RLSS Rod Locks match the cylinder profiles for easy, compact integration.

## CYLINDER REQUIREMENTS

- Longer cylinder rod  
Extra length = rod lock length (F) – cylinder pilot length  
(for dimensions, see pages 9 & 11)
- Hardened rod (preferred) or hard chrome plating: See Requirements for Optimal Performance for specifications.
- Longer tie rods on NFPA cylinders
- Mounting bolts included with ISO cylinders

## CYLINDER MOUNTED ROD LOCK SPECIFICATIONS

### NFPA Rod Locks, 'FM' Mounts

Rod Diameter	Bore Size	Holding Force	Rod Lock Model	Anodized P/N	Natural Finish P/N
0.625 in	1.500 in	180 lbs	RLSSB 150-063-C	966304	966303
0.625 in	2.000 in	314 lbs	RLSSB 200-063-C	966307	966306
0.625 in	2.500 in	491 lbs	RLSSB 250-063-C	966327	966326
1.000 in	2.000 in	250 lbs	RLSSB 200-100-C	966309	966308
1.000 in	3.250 in	830 lbs	RLSSB 325-100-C	966333	966332
1.000 in	4.000 in	1256 lbs	RLSSB 400-100-C	966337	966336
1.000 in	5.000 in	1963 lbs	RLSSB 500-100-C	966357	966356
1.375 in	4.000 in	1256 lbs	RLSSB 400-138-C	966339	966338
1.375 in	5.000 in	1963 lbs	RLSSB 500-138-C	966359	966358
1.375 in	6.000 in	2830 lbs	RLSSB 600-138-C	966363	966362

### ISO Rod Locks

Rod Diameter	Bore Size	Holding Force	Rod Lock Model	Anodized P/N	Natural Finish P/N
12 mm	32 mm	800 N	RLSSB 032-012-C	966048	966036
16 mm	40 mm	890 N	RLSSB 040-016-C	966049	966029
20 mm	50 mm	1400 N	RLSSB 050-020-C	966050	966030
20 mm	63 mm	2225 N	RLSSB 063-020-C	966051	966031
25 mm	80 mm	3560 N	RLSSB 080-025-C	966052	966032
25 mm	100 mm	5500 N	RLSSB 100-025-C	966053	966033
32 mm	125 mm	8560 N	RLSSB 125-032-C	966054	966034

### Locking Mode Sensors

Sinking (NPN) Normally Open	966190
Sourcing (PNP) Normally Open	966195

## ROD LOCK OPERATION SPECIFICATIONS

- › All of Nexen's Rod Locks will operate in both directions, engaging with the same holding force.
- › Rod Locks can be mounted in any position.
- › Rod rotation is not allowed when a Rod Lock is engaged (not intended for torsional braking).
- › Nexen's Rod Lock complies with ISO 15552 standards.
- › Release pressures can range from 4–8 bar [60–120 psi].
- › The Buna-N seals used are rated to 100°C [212°F].
- › Allowable operating temperatures range from 0.5°C–66°C [33°F–150°F]. Units are capable of intermittent use at temperatures up to 100°C [212°F].

## ROD LOCK AIR CHAMBER VOLUME & ENGAGEMENT TIME

### NFPA Rod Locks

Model	Air Chamber Volume	Approximate Engagement Time (sec)
RLSSB 150-063	0.25 in <sup>3</sup>	0.030
RLSSB 200-063	0.71 in <sup>3</sup>	0.040
RLSSB 250-063	1.26 in <sup>3</sup>	0.045
RLSSB 200-100	0.68 in <sup>3</sup>	0.040
RLSSB 325-100	3.20 in <sup>3</sup>	0.070
RLSSB 400-100	6.73 in <sup>3</sup>	0.100
RLSSB 500-100	11.50 in <sup>3</sup>	0.150
RLSSB 400-138	4.78 in <sup>3</sup>	0.100
RLSSB 500-138	9.50 in <sup>3</sup>	0.130
RLSSB 600-138	14.08 in <sup>3</sup>	0.175

### ISO Rod Locks

Model	Air Chamber Volume	Approximate Engagement Time (sec)
RLSSB 032-012	4.75 cm <sup>3</sup>	0.030
RLSSB 040-016	6.72 cm <sup>3</sup>	0.030
RLSSB 050-020	9.18 cm <sup>3</sup>	0.035
RLSSB 063-020	13.44 cm <sup>3</sup>	0.045
RLSSB 080-025	31.95 cm <sup>3</sup>	0.060
RLSSB 100-025	112.74 cm <sup>3</sup>	0.100
RLSSB 125-032	163.70 cm <sup>3</sup>	0.130

## REQUIREMENTS FOR OPTIMAL PERFORMANCE

Nexen's series of Static Rod Locks must be used in an application that meets the following specifications:

- Nexen's Static Rod Lock is suitable for infrequent dynamic braking (emergency stops) when used with hardened shaft material. Because the RLSS line is designed for static applications, repeated dynamic stops will cause rod and/or collar wear and reduce holding forces.
- If personnel safety is required, an unrelated, redundant safety system is recommended.
- Nexen recommends the following rod material for cylinder rods and guide rods. Deviations from these specifications will result in poor rod lock performance and shaft damage.

Hardness Specification	Hard Chrome Plating Thickness
Less than 52 HRC	20 microns [0.0008 inch]
Greater than 52 HRC	8 - 13 microns [0.0003 - 0.0005 inch]

- Nexen recommends a surface roughness Rmax of 1.6 microns [63 micro inch] or better.
- The Rod Lock requires clean, dry, pressure regulated air. Lubrication is not required.
- The rated holding force corresponds to static load conditions. If the rated value is exceeded, slipping may occur.
- The rod must be kept clean and dry to maintain optimum holding forces.
- Cylinder pilot must properly mate with rod lock seal for IP67 rating. Consult Nexen for use in wash-down or humid environment applications.
- The rod diameter must be within the h8 tolerance range. Refer to USAS (ANSI) B4.1-1967 (1974), ISO 286-1-1988, ISO 286-2-1988. Specify precision, hardened and ground, HRC, linear shafting.

# AIR CONTROLS AND PROGRAMMING

Minimum release pressure = 4 bar [60 psi]  
 Maximum pressure = 8 bar [120 psi]

## CYLINDER MOUNTING

**NOTE:** Avoid repeated overlapping conditions when programming the Rod Lock into your system. (i.e.: forced motion during engagement or disengagement of the Rod Lock.) Shaft and/or collar wear will result. Design the control system to use the Rod Lock in static conditions.

Cylinder functioning is regulated by a 5/3 (5 ported, 4-way, 3 [center] position) valve (use cylinder manufacturers' recommended Cv valves), center open on the central port and supplied by exhaust ports.

**NOTE:** Do not use a valve with a closed center. This will cause imbalance in the piston if any of the circuits leak.

One-directional flow reducers can be used to control the speed of the cylinder rod. To ensure fast braking of the rod, a quick exhaust valve can be installed on or near the rod lock.

A normally closed (NC) 3-way solenoid valve directs air supply to the rod lock, keeping it disengaged until the electrical signal is interrupted.

**Vertical Mounting:** The force on the piston must not exceed its locking capacity when it is combined with the force of the load.

Use of a 5/3 (5 ported, 4-way, 3 [center] position) valve provides a braking effect and maintains accurate rod positioning. Stopping precision is determined by the rate of speed of the rod and loads in motion.

**Horizontal Mounting:** Pressure is maintained on both sides of the cylinder piston, keeping it balanced and preventing rod displacement upon release. Use exhaust ports 3 and 5 (see below).

**STAND-ALONE MOUNTING:** Specifications match those of the cylinder models listed above.

Air Control Products		Part Number
Quick Exhaust Valve		170048
3-way Solenoid Valve, NC	24 V	964650
3-way Solenoid Valve, NC	115 V	948804

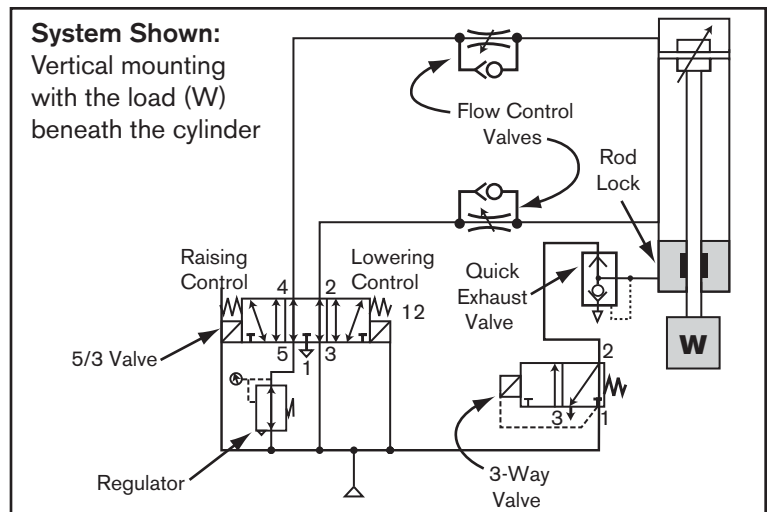
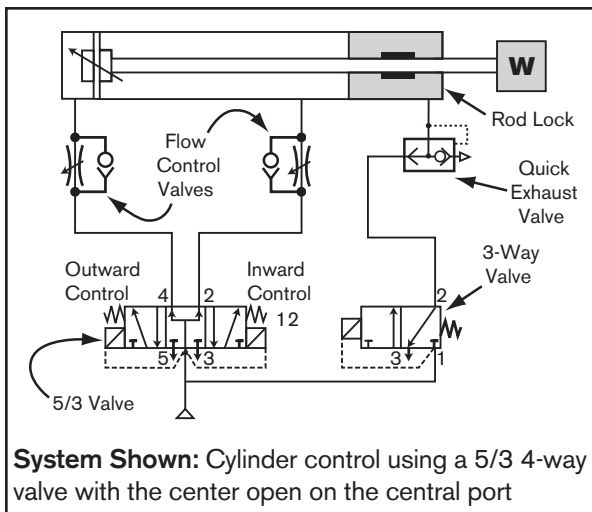
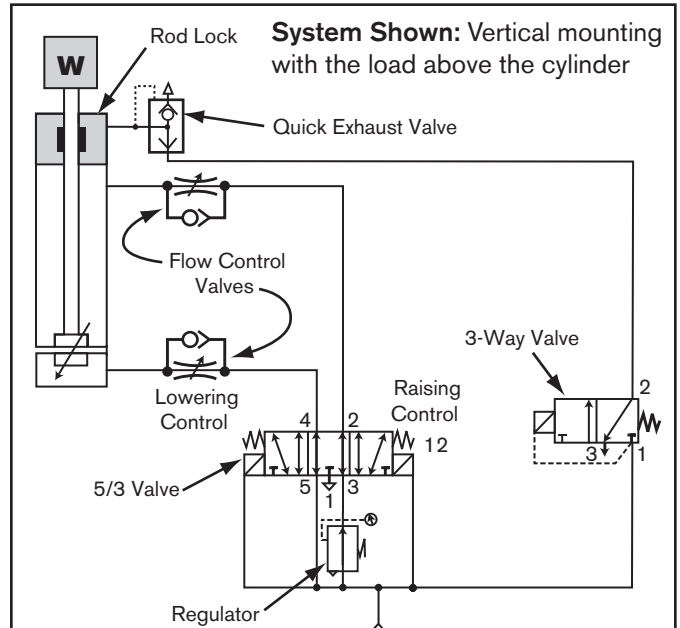

## Stand-alone Rod Locks for Inch Guide Rods, Approximate Dimensions

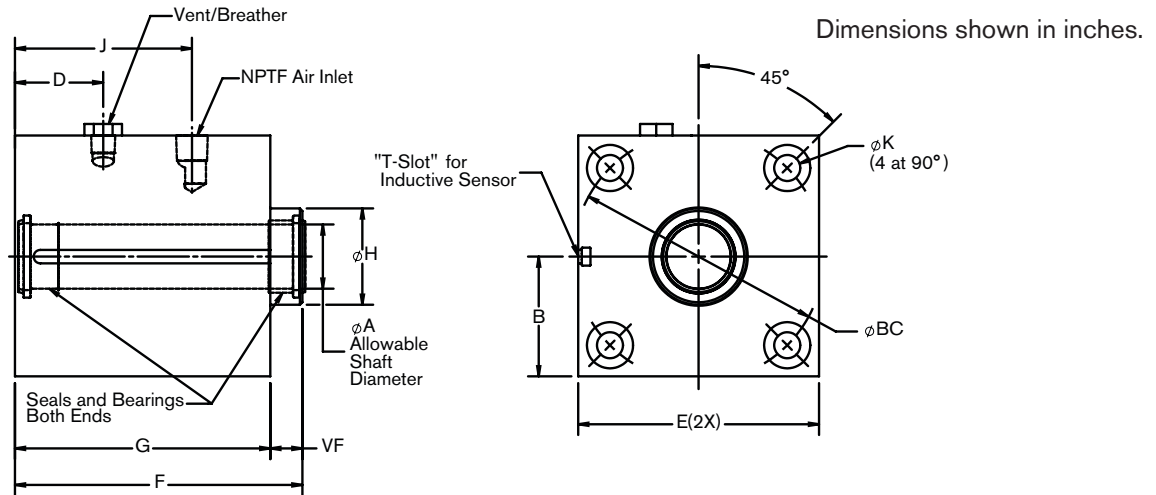

RLSSB Model	Product Number	$\phi A$ <sup>+0.00</sup> / <sub>-0.02</sub>	B (to slot)	$\phi BC$	D	E	F	VF	G	$\phi H$ <sup>-0.01</sup> / <sub>-0.03</sub>	J	K			NPT Air Inlet
												$\phi$	$\perp$	$\nabla$	
150-063-S	See page 4 for product numbers.	0.625	0.990	2.022	1.01	2.00	2.77	0.375	2.397	1.125	1.91	0.281	0.438	0.91	1/8-27
200-063-S		0.625	1.240	2.602	1.00	2.50	2.80	0.375	2.422	1.125	1.98	0.344	0.516	1.03	1/8-27
250-063-S		0.625	1.490	3.097	1.04	3.00	2.92	0.375	2.540	1.125	2.09	0.344	0.516	1.03	1/8-27
200-100-S		1.000	1.240	2.602	1.59	2.50	3.88	0.500	3.375	1.500	2.71	0.344	0.516	1.03	1/8-27
325-100-S		1.000	1.865	3.903	1.37	3.75	4.48	0.500	3.976	1.500	2.76	0.406	0.719	1.28	1/4-18
400-100-S		1.000	2.559	4.695	1.69	4.50	4.48	0.500	3.976	1.500	2.83	0.406	0.719	1.28	1/4-18
500-100-S		1.000	2.740	5.798	1.50	5.50	4.94	0.500	4.443	1.500	3.23	0.531	0.844	1.50	1/4-18
400-138-S		1.375	2.240	4.695	1.63	4.50	4.92	0.750	4.165	2.000	2.92	0.406	0.719	1.28	1/4-18
500-138-S		1.375	2.740	5.798	1.54	5.50	5.72	0.625	5.095	2.000	3.66	0.531	0.844	1.50	1/4-18
600-138-S		1.375	3.661	6.901	1.87	6.46	5.93	0.625	5.306	2.000	3.64	0.545	0.844	1.50	1/4-18

## Stand-alone Rod Locks for Metric Guide Rods, Approximate Dimensions

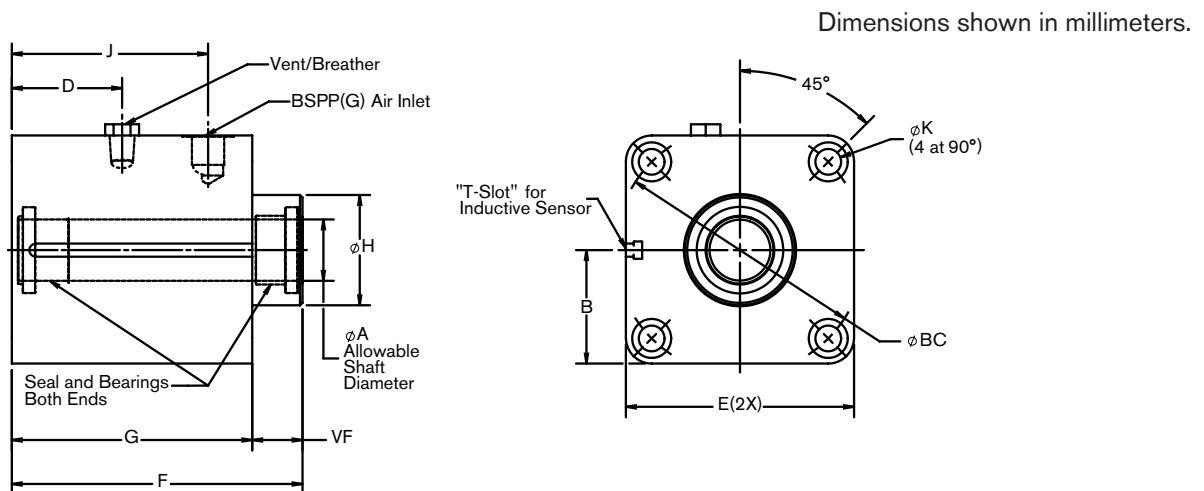

RLSSB Model	Product Number	$\phi A$	B (to slot)	$\phi BC$	D	E	F	VF	G	$\phi H$	J	K			BSPP Air Inlet
												$\phi$	$\perp$	$\nabla$	
032-012-S	See page 4 for product numbers.	12.000 +0/-0.034	29.41	45.96	27.6	48.0	89.8	17.00	70.82	30.00 -0.08/-0.23	48.8	6.35	10.00	24.00	1/8-28
040-016-S		16.000 +0/-0.034	26.75	53.74	31.5	54.0	87.0	21.50	64.50	35.00 -0.08/-0.23	56.1	6.35	10.00	24.00	1/8-28
050-020-S		20.000 +0/-0.041	31.75	65.76	47.2	64.0	105.3	24.30	79.50	40.00 -0.08/-0.23	71.5	8.40	13.00	26.50	1/8-28
063-020-S		20.000 +0/-0.033	47.19	79.90	46.5	75.0	104.5	20.00	83.00	45.00 -0.08/-0.13	75.0	8.40	13.00	26.50	1/8-28
080-025-S		25.000 +0/-0.041	46.25	101.82	44.9	93.0	118.5	20.50	98.00	45.00 -0.08/-0.13	80.0	10.50	15.90	44.60	1/4-19
100-025-S		25.000 +0/-0.041	72.96	125.87	44.5	110.0	124.5	20.50	104.00	55.00 -0.08/-0.13	93.0	10.50	15.90	44.60	1/4-19
125-032-S		32.000 +0/-0.039	69.75	155.56	76.0	140.0	174.5	27.50	147.00	60.00 -0.08/-0.13	116.0	12.50	19.05	56.40	1/4-19

## Rod Locks for NFPA Cylinders, Approximate Dimensions

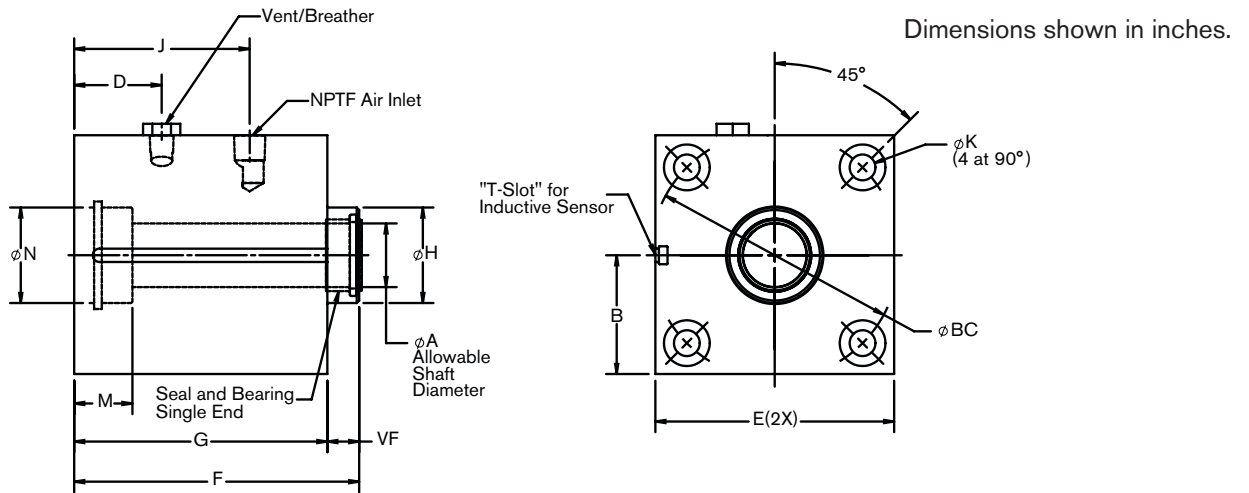

RLSSB Model	Product Number	$\phi A$ <sup>+0.00</sup> / <sub>-0.02</sub>	B (to slot)	$\phi BC$	D	E	F	VF	G	$\phi H$ <sup>-0.01</sup> / <sub>-0.03</sub>	J	K			M	$\phi N$ <sup>+0.03</sup> / <sub>+0.01</sub>	NPT Air Inlet
												$\phi$	$\perp$	$\nabla$			
150-063-C	See page 5 for product numbers.	0.625	0.990	2.022	1.01	2.00	2.77	0.375	2.397	1.125	1.91	0.281	0.438	1.25	0.65	1.125	1/8-27
200-063-C		0.625	1.240	2.602	1.00	2.50	2.80	0.375	2.422	1.125	1.98	0.344	0.516	1.03	0.67	1.125	1/8-27
250-063-C		0.625	1.490	3.097	1.04	3.00	2.92	0.375	2.540	1.125	2.09	0.344	0.516	1.03	0.67	1.125	1/8-27
200-100-C		1.000	1.240	2.602	1.59	2.50	3.88	0.500	3.375	1.500	2.71	0.344	0.516	1.03	0.90	1.500	1/8-27
325-100-C		1.000	1.865	3.903	1.37	3.75	4.48	0.500	3.976	1.500	2.76	0.406	0.719	1.28	0.91	1.500	1/4-18
400-100-C		1.000	2.559	4.695	1.69	4.50	4.48	0.500	3.976	1.500	2.83	0.406	0.719	1.28	0.88	1.500	1/4-18
500-100-C		1.000	2.740	5.798	1.50	5.50	4.94	0.500	4.443	1.500	3.23	0.531	0.844	1.50	0.87	1.500	1/4-18
400-138-C		1.375	2.240	4.695	1.63	4.50	4.92	0.750	4.165	2.000	2.92	0.406	0.719	1.28	1.07	2.000	1/4-18
500-138-C		1.375	2.740	5.798	1.54	5.50	5.72	0.625	5.095	2.000	3.66	0.531	0.844	1.50	1.07	2.000	1/4-18
600-138-C		1.375	3.661	6.901	1.87	6.46	5.93	0.625	5.306	2.000	3.64	0.545	0.844	1.50	1.05	2.000	1/4-18

## Rod Locks for ISO Cylinders, Approximate Dimensions

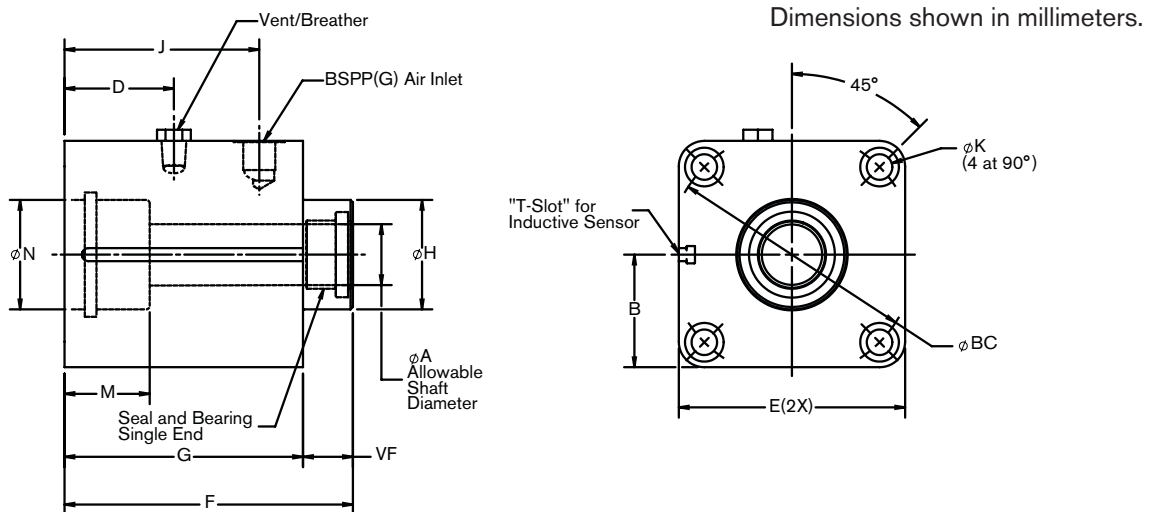

RLSSB Model	Product Number	$\phi A$	B (to slot)	$\phi BC$	D	E	F	VF	G	$\phi H$	J	K			M	$\phi N$	BSPP Air Inlet
												$\phi$	$\perp$	$\nabla$			
032-012-C	See page 5 for product numbers.	12.000 +0/-0.034	29.41	45.96	27.6	48.0	89.8	17.00	70.82	30.00 -0.08/-0.23	48.8	6.35	10.00	24.00	20.6	30.00 +0.25/-0	1/8-28
040-016-C		16.000 +0/-0.034	26.75	53.74	31.5	54.0	87.0	21.50	64.50	35.00 -0.08/-0.23	56.1	6.35	10.00	24.00	22.5	35.00 +0.25/-0	1/8-28
050-020-C		20.000 +0/-0.041	31.75	65.76	47.2	64.0	105.3	24.30	79.50	40.00 -0.08/-0.23	71.5	8.40	13.00	26.50	29.6	40.00 +0.23/+0.08	1/8-28
063-020-C		20.000 +0/-0.033	47.19	79.9	46.5	75.0	104.5	20.00	83.00	45.00 -0.08/-0.13	75.0	8.40	13.00	26.50	29.5	45.00 +0.23/+0.08	1/8-28
080-025-C		25.000 +0/-0.041	46.25	101.82	44.9	93.0	118.5	20.50	98.00	45.00 -0.08/-0.13	80.0	10.50	15.90	44.60	35.0	45.00 +0.25/-0	1/4-19
100-025-C		25.000 +0/-0.041	72.96	125.87	44.5	110.0	124.5	20.50	104.00	55.00 -0.08/-0.13	93.0	10.50	15.90	44.60	38.5	55.00 +0.25/-0	1/4-19
125-032-C		32.000 +0/-0.039	69.75	155.56	76	140.0	174.5	27.50	147.00	60.00 -0.08/-0.13	116.0	12.50	19.05	56.40	50.8	60.00 +0.25/-0	1/4-19

# ROD LOCKS WITH MANUAL RELEASE FOR NFPA AND ISO CYLINDERS

(Patent Pending)

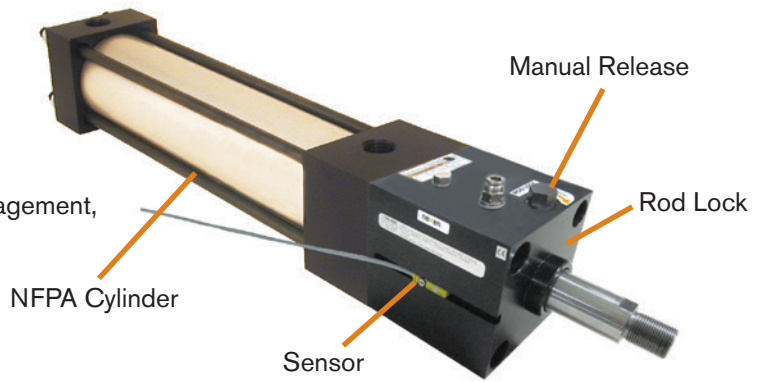

## Manual Release Specifications

- Cam operated, default to the lock function
- No special tools needed for manual disengagement, uses standard size hex head
- Stainless steel disengagement screw
- Locking mode feedback sensor (optional)
- Tested and rated to 5,000 cycles

## NFPA Models

Description	Bore Size (in)	Air Chamber Volume (in <sup>3</sup> )	Approximate Engagement Time (t <sub>e</sub> ) (seconds)	Rated Holding Force (F) (lbs)	Minimum Torque to Override (ft-lbs)	Anodized Product Number	Natural Product Number
<b>.625" Cylinder Rod</b>							
RLSSB 150-063-C-MR	1.50	0.25	0.030	180	2	966105	966106
RLSSB 200-063-C-MR	2.00	0.71	0.040	314	5	966116	966126
RLSSB 250-063-C-MR	2.50	1.26	0.045	491	7	966123	966128
<b>1.000" Cylinder Rod</b>							
RLSSB 200-100-C-MR	2.00	0.68	0.040	250	5	966117	966127
RLSSB 250-100-C-MR	2.50	1.49	0.050	491	7	966124	N/A
RLSSB 325-100-C-MR	3.25	3.20	0.070	830	17	966134	966139
RLSSB 400-100-C-MR	4.00	6.73	0.100	1256	45	966144	966157
RLSSB 500-100-C-MR	5.00	11.50	0.150	1963	72	966155	966159
<b>1.375" Cylinder Rod</b>							
RLSSB 325-138-C-MR	3.25	2.11	0.060	830	17	966136	N/A
RLSSB 400-138-C-MR	4.00	4.78	0.100	1256	45	966147	966158
RLSSB 500-138-C-MR	5.00	9.50	0.130	1963	72	966156	966165
RLSSB 600-138-C-MR	6.00	14.08	0.175	2830	135	966162	966166
* RLSS 800-138-C-MR	8.00	22.66	0.265	5026	160	966383	N/A
<b>1.750 Cylinder Rod</b>							
RLSSB 600-175-C-MR	6.00	12.75	0.165	2830	135	966385	N/A
* RLSS 800-175-C-MR	8.00	23.21	0.265	5026	160	966384	N/A
<b>2.500 Cylinder Rod</b>							
* RLSS 800-250-C-MR	8.00	17.53	0.210	4020	160	966388	N/A

\* These products do not have locking mode sensor T slot provisions.

## ISO Models

Description	Bore Size (mm)	Air Chamber Volume (cm <sup>3</sup> )	Approximate Engagement Time (t <sub>e</sub> ) (seconds)	Rated Holding Force (F) (N)	Minimum Torque to Override (N-m)	Anodized Product Number	Natural Product Number
<b>12mm Cylinder Rod</b>							
RLSSB 032-012-C-MR	32	4.75	0.030	800	3	966046	966038
<b>16mm Cylinder Rod</b>							
RLSSB 040-016-C-MR	40	6.72	0.030	890	3	966019	966039
<b>20mm Cylinder Rod</b>							
RLSSB 050-020-C-MR	50	9.18	0.035	1400	7	966020	966040
RLSSB 063-020-C-MR	63	13.44	0.045	2225	12	966021	966041
<b>25mm Cylinder Rod</b>							
RLSSB 080-025-C-MR	80	31.95	0.060	3560	22	966022	966042
RLSSB 100-025-C-MR	100	112.74	0.100	5500	65	966023	966043
<b>32mm Cylinder Rod</b>							
RLSSB 125-032-C-MR	125	163.70	0.130	8560	100	966024	966044

## Locking Mode Sensors

Sinking (NPN) Normally Open	966190
Sinking (PNP) Normally Open	966195

# Rod Locks with Manual Release for NFPA and ISO Cylinders, Approximate Dimensions

Product numbers on previous page.

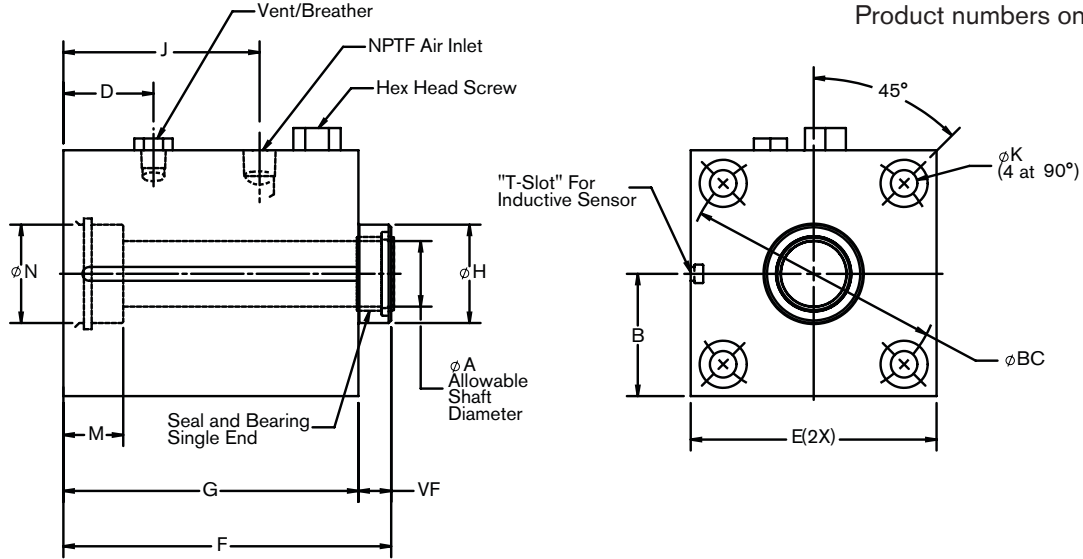

NFPA (Dimensions shown in inches)

Description	øA <sup>+0.000</sup> <sub>-0.002</sub>	B (to slot)	øBC	D	E	F	VF	G	øH <sup>-0.001</sup> <sub>-0.003</sub>	J	K			M	øN <sup>+0.003</sup> <sub>+0.001</sub>	NPT Air Inlet	Hex Head
											ø	└┘	└┘				
<b>.625" Cylinder Rod</b>																	
RLSSB 150-063-C-MR	0.625	0.990	2.022	1.01	2.00	3.00	.0375	2.625	1.125	1.91	0.281	0.438	.091	0.65	1.125	1/8-27	5/16
RLSSB 200-063-C-MR	0.625	1.240	2.602	1.00	2.50	3.25	0.375	2.875	1.125	1.98	0.344	0.516	1.03	0.67	1.125	1/8-27	1/2
RLSSB 250-063-C-MR	0.625	1.490	3.097	1.04	3.00	3.38	0.500	2.875	1.125	2.12	0.344	0.516	1.03	0.67	1.125	1/8-27	1/2
<b>1.000" Cylinder Rod</b>																	
RLSSB 200-100-C-MR	1.000	1.240	2.602	1.67	2.50	4.38	0.500	3.875	1.500	2.81	0.344	0.516	1.03	0.90	1.500	1/8-27	1/2
RLSSB 250-100-C-MR	1.000	1.490	3.097	1.55	3.00	4.50	0.500	4.000	1.500	2.88	0.344	0.516	1.03	0.90	1.500	1/8-27	1/2
RLSSB 325-100-C-MR	1.000	1.865	3.903	1.37	3.75	5.00	0.500	4.500	1.500	2.99	0.406	0.719	1.28	0.91	1.500	1/4-18	5/8
RLSSB 400-100-C-MR	1.000	2.559	4.695	1.69	4.50	5.38	0.500	4.875	1.500	3.15	0.406	0.719	1.28	0.88	1.500	1/4-18	7/8
RLSSB 500-100-C-MR	1.000	2.740	5.798	1.50	5.50	5.88	0.500	5.375	1.500	3.38	0.531	0.844	1.50	0.88	1.500	1/4-18	7/8
<b>1.375" Cylinder Rod</b>																	
RLSSB 325-138-C-MR	1.375	1.865	3.903	1.68	3.75	5.50	0.625	4.875	2.000	3.23	0.406	0.719	1.28	1.00	2.000	1/4-18	5/8
RLSSB 400-138-C-MR	1.375	2.240	4.695	1.63	4.50	5.88	0.750	5.125	2.000	3.45	0.406	0.719	1.28	1.08	2.000	1/4-18	7/8
RLSSB 500-138-C-MR	1.375	2.740	5.798	1.54	5.50	6.50	0.750	5.750	2.000	3.42	0.531	0.844	1.50	1.07	2.000	1/4-18	7/8
RLSSB 600-138-C-MR	1.375	3.661	6.901	1.87	6.46	7.13	0.755	6.375	2.000	3.67	0.545	0.844	1.50	1.06	2.000	1/4-18	1-5/16
* RLSS 800-138-C-MR	1.375	N/A	9.108	1.99	8.50	7.38	0.755	6.625	2.000	3.74	0.656	---	---	1.05	2.000	1/4-18	1-5/16
<b>1.750" Cylinder Rod</b>																	
RLSSB 600-175-C-MR	1.750	3.661	6.901	1.95	6.46	7.75	0.875	6.875	2.375	3.82	0.545	0.844	1.50	1.20	2.375	1/4-18	1-5/16
* RLSS 800-175-C-MR	1.750	N/A	9.108	2.10	8.50	8.00	0.875	7.125	2.375	3.98	0.656	---	---	1.23	2.375	1/4-18	1-5/16
<b>2.500" Cylinder Rod</b>																	
* RLSS 800-250-C-MR	2.500	N/A	9.108	2.75	8.50	8.88	1.380	7.500	3.125	4.35	0.656	---	---	1.57	3.125	1/4-18	1-5/16

\* These products do not have locking mode T slot provisions.

ISO (Dimensions shown in millimeters)

Description	øA	B (to slot)	øBC	D	E	F	VF	G	øH	J	K			M	øN	BSP	Hex Head
											ø	└┘	└┘				
<b>12 mm Cylinder Rod</b>																	
RLSSB 032-012-C-MR	12.000 +0/-0.034	29.41	45.96	27.6	48	89.8	17.00	70.82	30.00 -0.08/-0.23	48.0	6.35	10.00	24.00	20.6	30.00 +0.25/0	1/8-28	8
<b>16 mm Cylinder Rod</b>																	
RLSSB 040-016-C-MR	16.000 +0/-0.034	26.75	53.74	31.5	54	97.5	21.50	75	35.00 -0.08/-0.23	54.5	6.35	10.00	24.0	22.5	35.00 +0.25/0	1/8-28	8
<b>20 mm Cylinder Rod</b>																	
RLSSB 050-020-C-MR	20.000 +0/-0.041	31.75	65.76	47.2	64	123.8	24.30	98	40.00 -0.08/-0.23	71.0	8.40	13.00	26.5	29.6	40.00 +0.23/+0.08	1/8-28	13
RLSSB 063-020-C-MR	20.000 +0/-0.033	47.19	79.90	46.5	75	118.5	20.00	97	45.00 -0.08/-0.13	76.7	8.40	13.00	26.5	29.5	45.00 +0.23/+0.08	1/8-28	13
<b>25 mm Cylinder Rod</b>																	
RLSSB 080-025-C-MR	25.000 +0/-0.041	46.25	101.82	44.9	93	136.5	20.50	116	45.00 -0.08/-0.13	80.0	10.50	15.90	44.6	35.0	45.00 +0.25/0	1/4-19	16
RLSSB 100-025-C-MR	25.000 +0/-0.041	72.95	125.87	44.4	110	147.5	20.50	127	55.00 -0.08/-0.13	93.0	10.50	15.90	44.6	38.5	55.00 +0.25/0	1/4-19	22
<b>32 mm Cylinder Rod</b>																	
RLSSB 125-032-C-MR	32.000 +0/-0.039	69.75	155.56	76.0	140	194.5	27.50	167	60.00 -0.08/-0.13	116.0	12.50	19.05	56.4	50.9	60.00 +0.25/0	1/4-19	22

## Rod Lock Sample Calculations for Emergency Stops

E-stops performed with rod locks should be limited, as the rod lock and/or shaft friction surface may wear. Depending on the energy dissipated during a stop, the rod locks performance may be reduced after each stop.

### SAMPLE DATA

Lock Model <sup>1</sup>	Lock Force <sup>1</sup> (F)	Lock Engagement Time (t <sub>e</sub> ) <sup>1</sup>	Acceleration of Gravity (g)	Mass of Load (m)	Load Velocity (V)
RLSSB 032-012-S	800 N	0.030 seconds	9.8 m/s <sup>2</sup>	45.4 kg	0.50 m/s

<sup>1</sup>For lock specifications, see page 10.

### HORIZONTAL TRAVEL (X and Y axis)

#### Dynamic Stopping Time (in seconds):

$$t_T = \frac{m \cdot V}{F} + t_e$$

$$t_T = \frac{45.4 \cdot 0.50}{800} + .030 = 0.058 \text{ seconds}$$

#### Dynamic Stopping Distance (in meters):

##### Distance of Travel During Lock Engagement (L<sub>e</sub>)

$$L_e = V \cdot t_e$$

$$L_e = 0.5 \cdot 0.030 = 0.015 \text{ meters}$$

##### Stopping Distance (L<sub>s</sub>) at Full Lock Force

$$L_s = \frac{0.5 \cdot m \cdot V^2}{F}$$

$$L_s = \frac{0.5 \cdot 45.4 \cdot 0.50^2}{800} = 0.007 \text{ meters}$$

#### Total Travel Distance

$$L_T = L_e + L_s$$

$$L_T = 0.015 + 0.007 = 0.022 \text{ meters or } 22 \text{ mm}$$

In this example, the load will travel 22 mm [0.87 in] from the time the lock engages until the system is brought to a complete stop.

### VERTICAL TRAVEL (DOWNWARD) (Z axis)

#### Dynamic Stopping Time (in seconds):

$$t_T = \frac{m \cdot (g \cdot t_e + V)}{[F - (m \cdot g)]} + t_e$$

$$t_T = \frac{45.4 \cdot (9.8 \cdot 0.030 + 0.50)}{[800 - (45.4 \cdot 9.8)]} + 0.030 = 0.132 \text{ seconds}$$

#### Dynamic Stopping Distance (in meters):

##### Distance of Travel During Lock Engagement (L<sub>e</sub>)

$$L_e = 0.5 \cdot (t_e^2) \cdot g + V \cdot t_e$$

$$L_e = 0.5 \cdot (.030^2) \cdot 9.8 + .5 \cdot .030 = 0.019 \text{ meters}$$

##### Stopping Distance (L<sub>s</sub>) at Full Lock Force

$$L_s = 0.5 \cdot [(t_e \cdot g) + V] \cdot (t_T - t_e)$$

$$L_s = 0.5 \cdot [(0.030 \cdot 9.8) + 0.5] \cdot (0.132 - 0.030)$$

$$L_s = 0.040 \text{ meters}$$

#### Total Travel Distance

$$L_T = L_e + L_s$$

$$L_T = 0.019 + 0.040 = 0.059 \text{ meters or } 59 \text{ mm}$$

In this example, the load will travel 59 mm [2.32 in] from the time the lock engages until the system is brought to a complete stop.

E-stop travel distance must be less than 100 mm

[www.nexengroup.com](http://www.nexengroup.com)

In accordance with Nexen's established policy of constant product improvement, the specifications contained in this document are subject to change without notice. Technical data listed in this document are based on the latest information available at the time of printing and are also subject to change without notice. For current information, please consult [www.nexengroup.com](http://www.nexengroup.com)

**nexen**<sup>®</sup>

Nexen Group, Inc.  
560 Oak Grove Parkway  
Vadnais Heights, MN 55127

800.843.7445  
Fax: 651.286.1099  
[www.nexengroup.com](http://www.nexengroup.com)

Nexen has sales offices throughout the United States, Europe, Japan, and Australia.