



# Round Shaft Technology

Linear Bearings & Shafting



Configure Online at  
[pbclinear.com](http://pbclinear.com)

1-800-962-8979

# Contents

I Inch Series

M ISO Metric Series

J JIS Metric Series

16 Applications

7 Product Overview – Plain & Ball Bearing

9 Plain Bearings – Performance Benefits

18 Plain Bearings – Ordering Information

31 Ball Bearings – Overview

33 Ball Bearings – Ordering Information

## I INCH SERIES

### I Simplicity® Linear Plain Bearings

20 Closed FL      Open FLN



### I Linear Precision Ball Bearings

34 Closed IP      Adjustable IPxx-AJ      Open IPxx-OP



### I Linear Ball Bearings – Precision Plus Self-Aligning

35 Closed IPS      Open IPSxx-OP



### I Linear Ball Bearings – Double Wide

40 IP-W



### I Simplicity Pillow Blocks

22 Closed P      Open PN



### I Simplicity Pillow Blocks – Twin

23 Closed PW      Open PWN



### I Linear Ball Bearing Pillow Blocks

36 Closed IPP      Open IPPN



34 with Lubrication Port IPPS

### I Linear Ball Bearing Pillow Blocks – Twin

37 Closed IPPW      Open IPPWN



35 with Lubrication Port IPPSW

### I Simplicity Flange Mounts

24 Single SFP      Double DFP

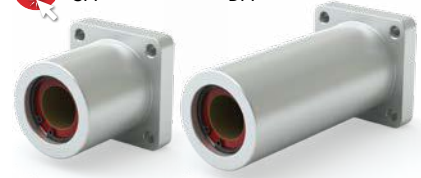

### I Die Set Flange Mounts

25 Single SDS      Double DDS



### I Die Set Bushings

28 PAC



### I Simplicity Sleeve Bearings

26 PS      With Flange PSF

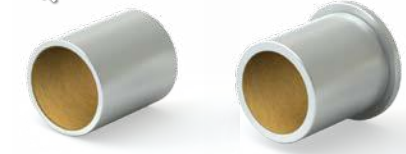

I Roller Pillow Block Bearings

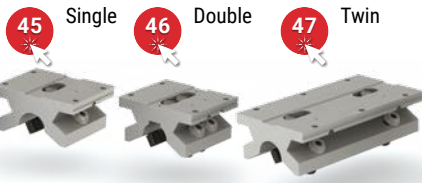

I Shaft & Rail Systems

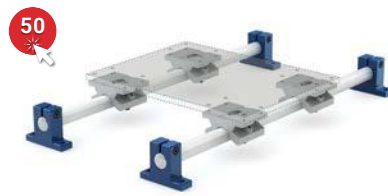

I Support Rail Systems



I Simplicity® 60 Plus® Shafting



I Support Rails & Assemblies



I Square Shafting, Bearings & Plugs



M ISO METRIC SERIES

M Simplicity Linear Plain Bearings

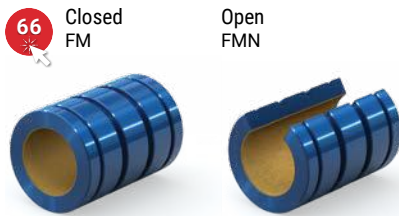

M Linear Ball Bearings – Precision Plus Self-Aligning



M Linear Precision Ball Bearings



M Linear Ball Bearings – Double Wide



M Simplicity Pillow Blocks

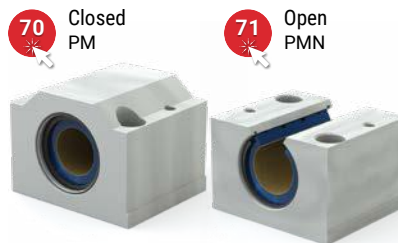

M Linear Ball Bearing Pillow Blocks

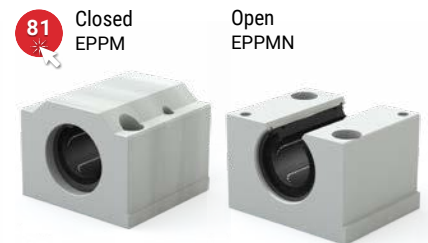

M Thin Wall Ball Bearings



M Thin Wall Plain Bearings



M Simplicity Flange Bearings – Single



M Simplicity Flange Bearings – Double

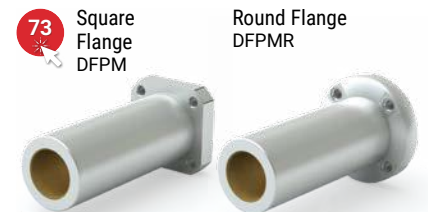

# Contents

**I** Inch Series

**M** ISO Metric Series

**J** JIS Metric Series

**M** Simplicity Flange Bearings – Center Flange

- 74** Square Flange CFPM
- Round Flange CFPMR



**M** Linear Ball Bearings – Single

- 82** Square Flange EPK
- 83** Round Flange EPF



**M** Linear Ball Bearings – Double

- 84** Square Flange EPK-W
- 85** Round Flange EPF-W



**M** Linear Ball Bearings – Center Flange

- 86** Square Flange EPKC
- 87** Round Flange EPFC



**M** Die Set Bushings

- 75** PACM



**M** Simplicity Sleeve Bearings

- 76** PSM
- 77** With Flange PSFM



**M** Roller Pillow Block Bearings

- 89** Single
- 89** Double
- 89** Twin



**M** Simplicity® 60 Plus® Shafting

- 91** RC60 Steel, Stainless Steel, NIM & NIMxxSS
- 92** Predrilled Shafts, Ceramic Coated, CCM & CCMDL

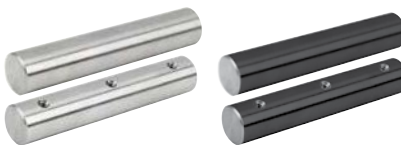

**M** Support Rails & Assemblies

- 93** Aluminum SRA, Ceramic Coated, CCR
- Aluminum SR & SRxxPD



**J** JIS METRIC SERIES

**J** Simplicity Linear Plain Bearings

- 95** Closed FJ
- Open FJN



**J** Linear Precision Ball Bearings

- 99** Closed JP
- Adjustable JPxx-AJ
- Open JPxx-OP



**J** Linear Ball Bearings – Double Wide

- 101** JP-W



J Simplicity Flange Bearings – Single

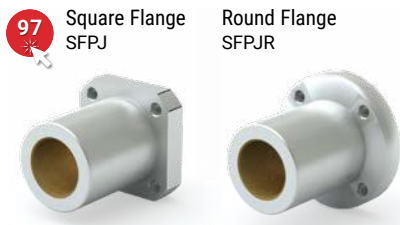

J Simplicity Flange Bearings – Double

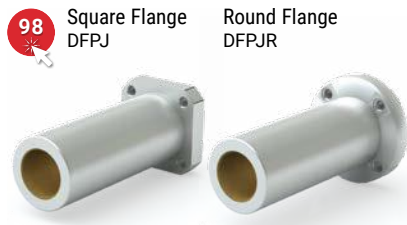

J Simplicity Flange Bearings – Center Flange

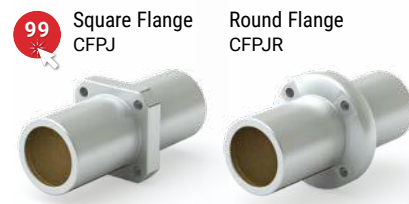

J Linear Ball Bearings – Single

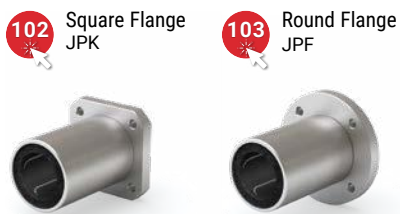

J Linear Ball Bearings – Double



J Linear Ball Bearings – Center Flange

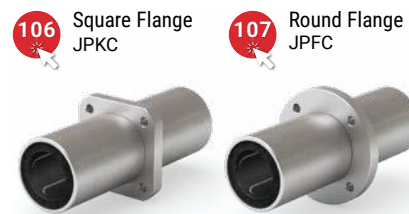

INCH SERIES PLAIN BEARING & BALL BEARING LINEAR SLIDES

Ordering information found on product pages

I Simplicity Linear Slides

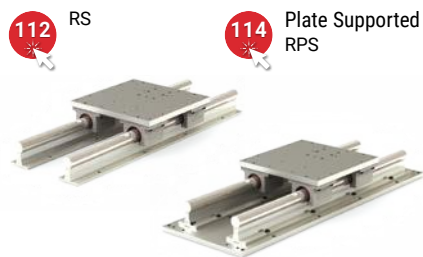

I Simplicity Linear Slides



I Simplicity Linear Slides



I Simplicity Linear Slides

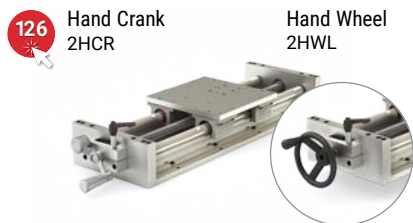

I Simplicity Linear Slides



@ Email an Application Engineer

TECHNICAL INFORMATION

Simplicity Linear Plain Bearings

- P138 - Ratings for Plain Bearings
- P139 - Types & Effects of Lubrication
- P140 - Load Capacity
- P141 - Wear Rate
- P142 - Coefficient of Friction

P143 - Cantilevered Loads

P145 - Shaft Deflection

P147 - Installation

P151 - Chemical Reaction Chart

Linear Ball Bearings

P152 - Load Ratings

P153 - Rating Life

P155 - Clearance & Mounting

Roller Pillow Block Bearings

P157 - Load & Sizing

P158 - Adjustments & Curves

P159 - Cross Reference Guide

# Check Out PBC Linear Configurators

Shafting • Roller Pillow Block • Support Rail Assembly

The PBC Linear configuration tools allow you to customize and configure linear components to exact specifications.

- Simple steps to configure and select product offerings
- Custom CAD file delivered in minutes
- Custom quote generated quickly and easily

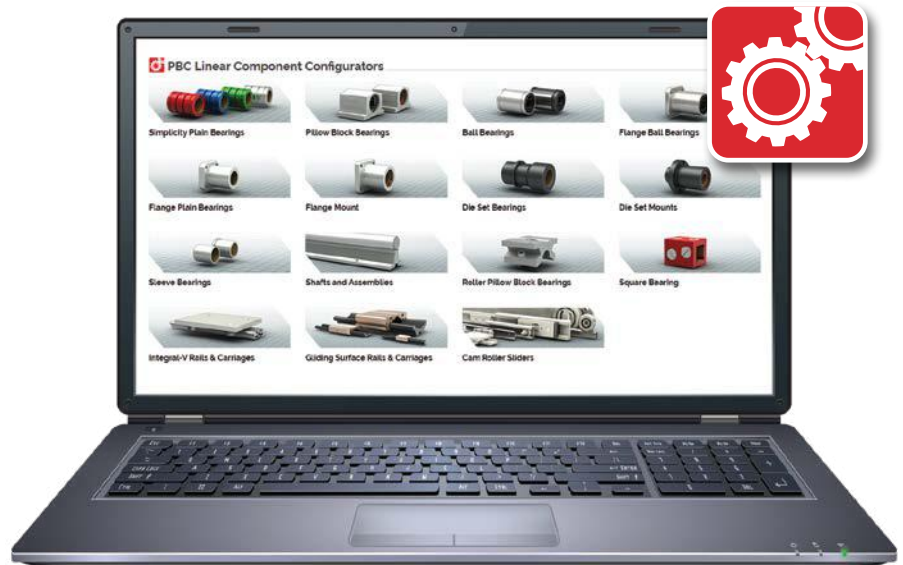

- Visit [pbclinear.com/tools/configure-quote](http://pbclinear.com/tools/configure-quote) and start designing!

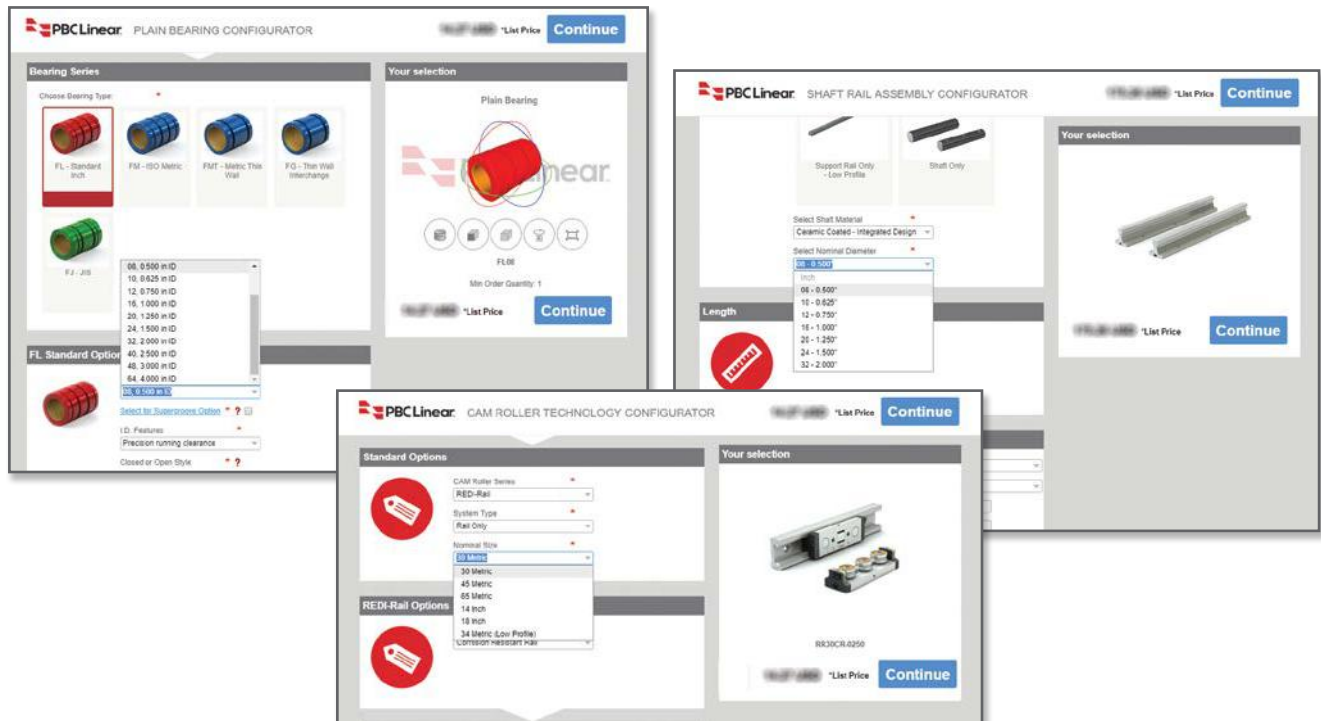

# Linear Shafting

Engineered for Maximum Linear Bearing Performance

**Simplicity**  
**60 PLUS**  
S H A F T I N G

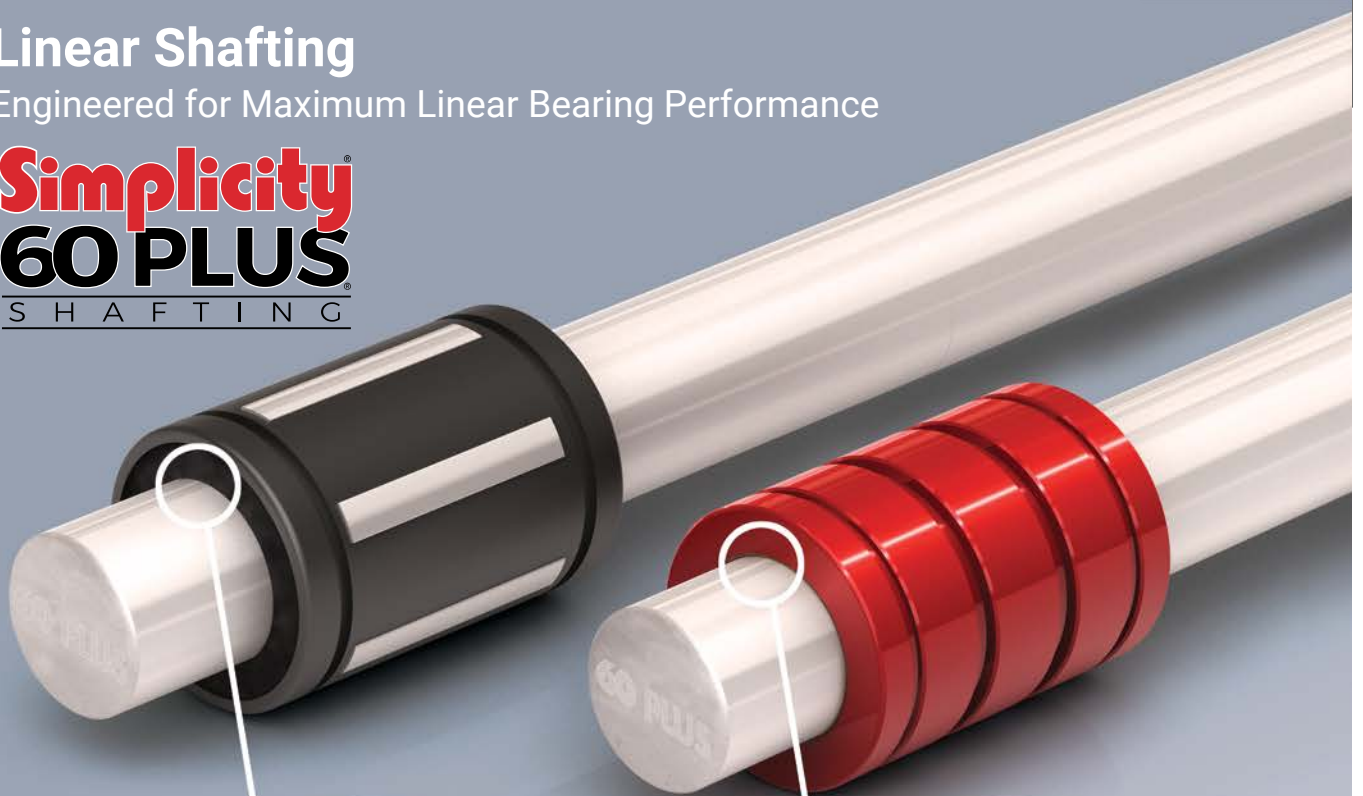

Optimized shaft finish  
for ball bearings

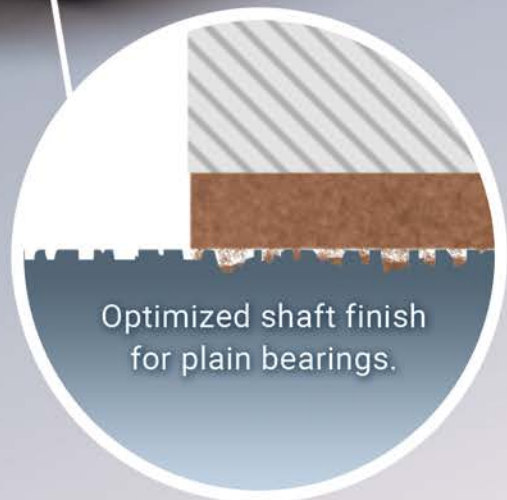

Optimized shaft finish  
for plain bearings.

## Linear Ball Bearings

The right amount of microscopic surface texture holds lubrication for consistent smooth ball rotation minimizing the effects of metal-to-metal contact.

- **Excellent Rigidity:** providing smooth, quiet operation
- **Extremely Low Friction:** rolling elements provide consistent anti-friction movement
- **Outer Shell:** Available with steel jacket or self-aligning super bearing shell

## Simplicity Plain Bearings

The Frelon® break-in and transfer process operates at maximum efficiency with Simplicity 60 Plus Shafting resulting in true self-lubrication and the longest life possible.

- **Self-Lubricating:** maintenance-free, additional lubrication optional
- **Wide Temperature Ranges:** (-400°F/+400°F), (-240°C/+204°C)
- **Vibration Damping:** eliminates fretting corrosion



Only certified *Simplicity 60 Plus* Shafting provides maximum bearing performance.











**Inch Series—page 52 Metric Series—page 90**

# Product Selection Guide

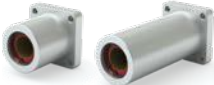
I Inch Series

M ISO Metric Series

J JIS Metric Series

Shape	Sizes	Product Type & Description	Available In:			Found On Page		
			Open	Closed	Wide	I	M	J
Round Bearings	I	<b>Plain</b> Materials: aluminum alloy, stainless steel						
	M	 Self lubricating bearing with patented compound of PTFE developed for improved performance over other bearings. Standard sizes in stock.	●	●		20	66	95
	J							
	I	<b>Ball</b> Materials: steel and polymer						
	M	 Each ball bearing consists of an outer cylinder, ball retainer, balls, and double seals.	●	●	●	34	78	100
	J							
	M	<b>Thin Wall</b> Materials: aluminum alloy housing anodized or steel with polymer retainer			●		88	
Round Bearings with Housings	I	<b>Sleeve &amp; Sleeve with Flange</b> Materials: aluminum alloy housing						
	M	 Replaces Oilite, bronze, and plastic bearings. Ideal for slow or moderate speeds for oscillating or rotary motion.		●		26	76	
	I	<b>Roller Pillow Blocks</b> Materials: aluminum and coated steel rollers						
	M	 Well suited for high loads and high speeds. Excels in contaminated environments and under high temperatures.	●			45	89	
	I	<b>Open &amp; Closed Pillow Blocks</b> Materials: aluminum alloy housing with clear anodized coating						
	M	 Available with either plain or ball bearings. Self aligning for ease of mounting. Standard sizes in stock.	●	●	●	22	70	
Round Bearings with Housings	I	<b>Flange Mount</b> Materials: aluminum alloy housing with clear anodized coating and inner plain bearing						
	M	 Ease of mounting. Compact design.	●		●	24		
	J							
	M	<b>Flange Bearing</b> Materials: aluminum alloy housing with clear anodized coating or steel with polymer retainer						
	J	 Both plain and ball bearing available. Ease of mounting. Compact design.		●	●		72	97
Round Shafting	I	<b>Die Set Flange Bushings</b> Materials: aluminum housing with black anodized coating and inner plain bearing						
	M	 Mounting precision. Size interchangeable with industry standard die sets.		●	●	25	75	
	M							
Pre-Assembled Round Shaft	I	<b>Round Shafting</b> Materials: ceramic coated aluminum, hardened steel, 440 stainless steel						
	M	 Cut to length, random lengths, machined, pre-drilled, or tapped. Shaft assemblies and support rails also available.				52	91	
Square Bearings & Shafting	I	<b>Linear Slide Assemblies</b> Materials: alloy steel, 440 stainless steel, ceramic coated, or chrome plated 303 SST shafts, aluminum support rails, standard Simplicity pillowblocks						
	M	 Plain bearing and ball bearing slide assemblies. Standard components include mounting plate, pillow block assemblies, steel shafts, and support rails. Options include shaft materials, lead screws, ball screws, hand cranks, and motors.				109		
Square Bearings & Shafting	I	<b>Square Bearings &amp; Shafting</b> Materials: aluminum alloy housing with red anodized coating and stainless steel square shafting						
	M	 Resists torque and eliminates extra costly components in parallel shafts.		●		61		

# Simplicity® Plain Bearing Product Overview

## Linear Plain and Ball Bearings



Good engineering principles dictate that the best bearing design be utilized for any given bearing application. Each type of bearing has advantages and disadvantages. Strengths or limitations can make it a clear choice depending on the application environment. At other times, an engineer will have a choice because multiple types of bearings can meet the need.

In 1983, PBC Linear® created the self-lubricating Simplicity linear bearing – a technology that solves problems in dirt, vibration, shock loading, cleanrooms, welding, foundry, and washdown situations where linear ball bearings regularly fail.

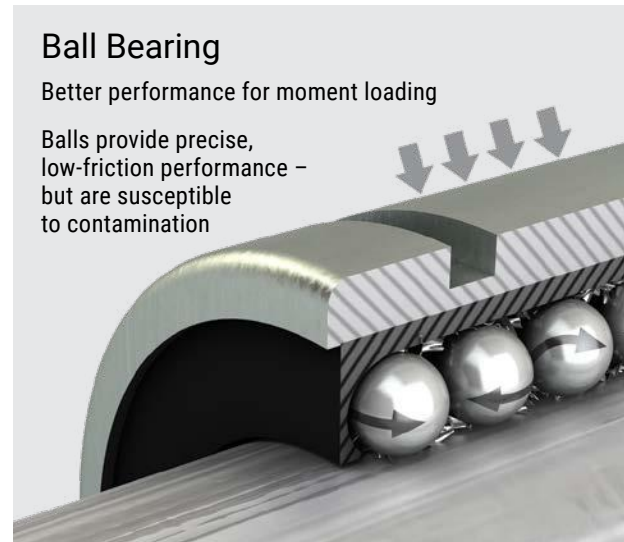
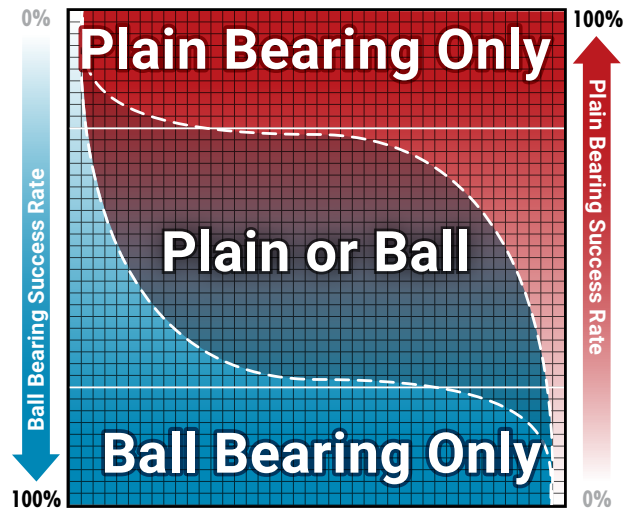
Today, PBC Linear provides a full range of linear motion solutions for both plain bearing and ball bearing applications – giving engineers the versatility to choose the right bearing for the application. Chart to the right here is intended to help guide in that decision making process.



PERFORMANCE

Bearing Type	Load	Moment Loads	Linear Speed	Coefficient Of Friction	Precision	Environment
 <b>Plain</b>	Up to 20x ball bearings	Limited due to 2:1 ratio  <a href="#">Link to 2:1 Ratio</a>	Up to 300 sfm (1.524 m/sec) dry running Up to 825 sfm (4.19 m/sec) with lubrication	FrelonGOLD® = 0.125 Consistent over life and in a variety of environments	Precision running clearance = 0.0005" (0.0127 mm) per side	Excels in contaminated, wet, dry, and clean room applications
 <b>Ball</b>	Limited due to point-to-point contact of balls to shaft	Moderate to good High moment loads can cause increased wear and shorten bearing life	Up to 3 m/sec (590 sfm) Always requires lubrication	Average = 0.002 Can change dramatically dependent on environmental conditions	Can be preloaded, virtually eliminating play This can shorten life	Will corrode and fail in contamination

# Performance Benefits Simplicity® Plain Bearings

## Frelon® + Precision Bearing Technology = Simplicity

- The Frelon liner is bonded to the bearing shell at the molecular level, which transfers the load and dissipates heat buildup throughout the bearing
- Will not rust or corrode due to anodized aluminum or 316 stainless steel shell
- Patented self-aligning capabilities are standard
- Provides both linear, oscillating, rotary, or any combination of motions
- Maintenance free operation
- Smooth and quiet operation – plus long life
- Highly accurate – all critical surfaces are ground on precision bearing grinders
- Will not catastrophically fail or damage shaft

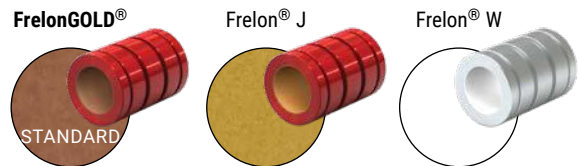
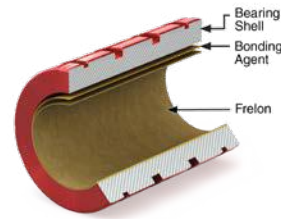

## Frelon Bearing Liner Materials

The Frelon liners are compounds of PTFE and fillers developed for improved performance over other bearings. They provide low wear, low friction, self-lubrication, and high strength.

### PTFE Features:

- Self-lubricating (runs without added lubricant)
- Embeddability of hard particulate
- Wide temperature range (-400°F to +400°F) (-240°C to +204°C)
- Chemically inert
- Vibration damping (no metal-to-metal contact)

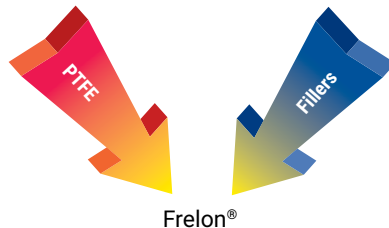

### Filler Benefits:

- High load capacity
- High strength
- Low wear rate vs. other materials

- FrelonGOLD® – dark gold high performance material compatible with RC60 hardened steel shafting, RC70 ceramic coated, & 400 series stainless steel shafting.
- Frelon J – yellow material formulated to provide the optimum performance with 300 series stainless steel and softer shafting such as bare aluminum.
- Frelon W – white color, food-grade liner, FDA compliant, compatible with stainless steel and softer metal shafting.
- PBC Linear's unique bonding process facilitates the ability to provide solutions for applications with a range of additional bearing liner materials. Contact PBC Linear to discuss your specific application.



Email an Application Engineer

PERFORMANCE

## Simplicity 60 Plus® Shafting

The PBC Linear development team, working in close conjunction with engineers from Lee Linear®, have together formulated a linear shaft designed specifically for optimal bearing performance – *Simplicity 60 Plus Shafting*. Advanced process capabilities maintain the ideal surface finish resulting in the longest life and highest performing shaft-to-bearing combination.

Don't be misled—all shafting is not alike! Don't settle for below average performance. The smoothest shafting is NOT always the best for all situations. **In most applications, smoother does not equal better; in fact, it means decreased performance and shortened life.** A shaft surface finish of 8-12 Ra is the optimal smoothness for linear plain and ball bearings.

**Simplicity 60 Plus Shafting provides maximum linear bearing performance and the following features:**

- Optimized shaft surface finish for plain bearings
- Customizable length and machined features via the configurator with no minimum quantities
- Faster Made in the USA



**Only certified Simplicity 60 Plus Shafting provides maximum linear bearing performance.**

**Inch Series—page 52 Metric Series—page 90**

# Plain Bearings Simplicity®

## Running Clearance

Simplicity bearings are available with two classes of running clearance:

### PRECISION—"FL":

- Performs like a preloaded ball bearing
- Tightest running clearance approximately 0.001" (0.025 mm)
- Used in applications that require high precision

**CAUTION** *Not recommended for all parallel shaft applications. Any misalignment can cause binding on the shaft. Recommend—"FLC" (see below).*

### COMPENSATED—"FLC":

- Performs like a standard ball bearing
- Additional clearance built into the I.D.—all other dimensions are the same as the precision bearings
- Ideally suited for parallel shaft applications

**Note:** Many parallel shaft applications will run "FL" precision on one rail and "FLC" compensation on the opposite rail to accommodate slight misalignments.

## Bearing Shell

Simplicity bearings are available in a variety of configurations to help meet specific application needs:

- Standard is aluminum alloy with anodized finish
- 316 stainless steel (no plating)

### MATERIALS:

**Aluminum Alloy** – Is a heat treated and artificially aged aluminum with good strength and corrosion resistance.

**316 Stainless Steel** – Has an excellent corrosion resistance and is widely used by the paper, food, and other industries.

### FINISHES:

**Standard Anodized** – A sulfuric bath anodizing with a nickel acetate seal that will stand up to 14 days exposure in a 5% salt spray solution at 96°F. It is applied at a 0.0002" thickness.

## RUNNING CLEARANCE

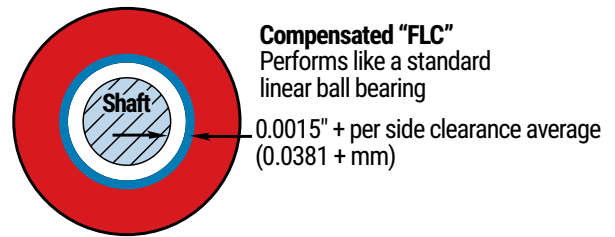
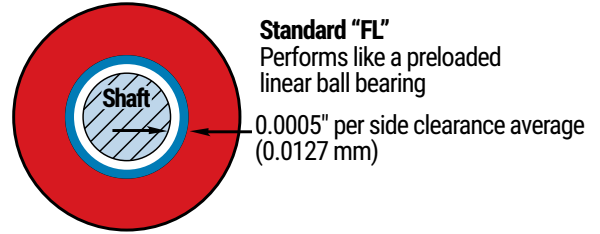

PERFORMANCE

 [Link to the Simplicity Video](#)

 [More Information about Simplicity's Chemical Resistance](#)

 **Only certified Simplicity 60 Plus Shafting provides maximum linear bearing performance.**  
**Inch Series—page 52 Metric Series—page 90**

### Standard



Inch Series

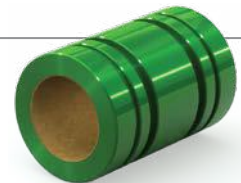

JIS Metric Series

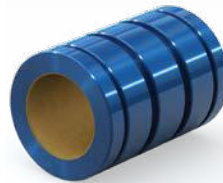

ISO Metric Series

### Optional



316 Stainless Steel

# Plain Bearings Simplicity®

## Self-Alignment Feature

Simplicity bearings are available with a standard straight O.D. or a crowned self-aligning O.D.

### FL – (Standard):

- Straight O.D.
- Standard pillow blocks have the self-aligning capability designed into the block using standard "FL" bearings for the final assembly

### FLA – (Self-aligning O.D.):

- Has a crown on the O.D. allowing the bearing to re-align itself in binding situations
- Specifically designed to easily retrofit straight bore housings
- The bearing will allow 1/2° of misalignment capability from centerline (1° overall)
- O-rings can be used on either side of the crown to cushion and eliminate clatter in operation (sold separately)

## Pillow Blocks

- Made of aluminum alloy
- Pillow blocks are interchangeable with industry standard ball bearing pillow blocks
- Critical centerline dimensions hold accuracy within  $\pm 0.001"$  on inch sizes and  $\pm 0.015$  mm on metric sizes

### FINISHES:

- Clear anodized finish (Standard)

### Standard pillow blocks have built-in self-alignment in all directions:

- Standard pillow blocks have 1/2° misalignment from centerline
- This feature is built into the housing with a spherical radius at the midpoint of the block
- This self-aligning capability will allow for some shaft deflection and misalignment

### Rigid or straight bore housings are available:

- This does not allow for any self-alignment and provides a very rigid assembly
- They are typically used in single shaft applications

## Open Bearings Orientation

Simplicity bearings can operate in any orientation. Load capacities will vary on open bearings depending on the orientation in which they are being used.

### Standard FL – Straight O.D.

**Note:** Standard pillow blocks use FL bearings with self-alignment built into the I.D. of the block.

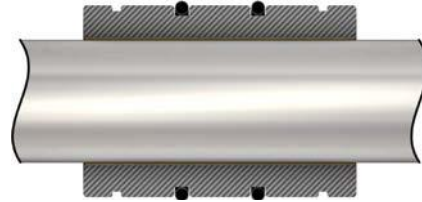

### Self-Aligning FLA – Spherical O.D.

**Note:** Use in straight bore housings.

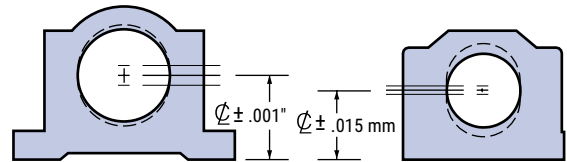
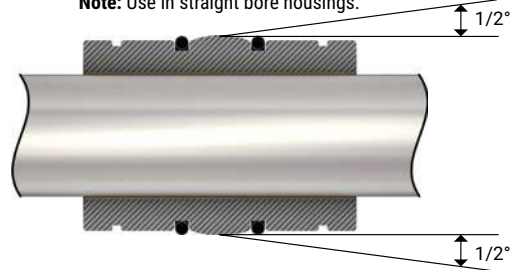

**SIMPLICITY = TIGHTER TOLERANCES**

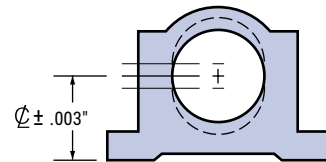

**INDUSTRY STANDARD**

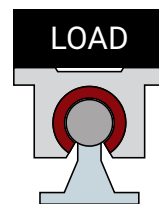

100% Capacity

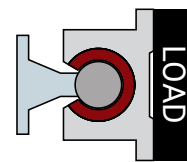

70% Capacity

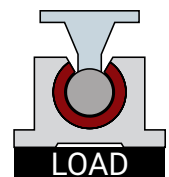

40% Capacity

# Plain Bearings Simplicity®

## Load Capacity of Liner

Simplicity bearings can carry from 4 to 20 times the load of a linear ball bearing.

Bearing Material	Static Load Capacity
FrelonGOLD®	3000 psi or 210.9 kgf/cm <sup>2</sup>
Frelon® J / Frelon® W	1500 psi or 105.45 kgf/cm <sup>2</sup>

- Allows the engineer to maintain performance in a smaller designed package  
**Example:** Simplicity 1/2" I.D. = 1" I.D. linear ball bearing
- Shock loads and vibration are absorbed
- Metal-to-metal contact is eliminated providing a smoother, quieter running assembly

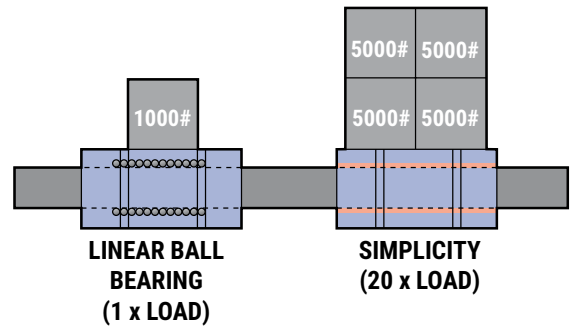

## Speed Characteristics

Exceeding these speeds causes frictional heat and accelerates liner wear.

Bearing Material	No Lube Continuous Motion	No Lube Intermittent Motion	With Lubrication*
FrelonGOLD®	300 sfm	825 sfm	825 sfm
	60 in./sec.	165 in./sec.	165 in./sec.
	1.524 m/sec.	4.19 m/sec.	4.19 m/sec.
Frelon® J / Frelon® W	140 sfm	400 sfm	400 sfm
	28 in./sec.	80 in./sec.	80 in./sec.
	0.711 m/sec.	2.03 m/sec.	2.03 m/sec.

\*Depending on the lubrication used, loads, and frequency of continuous or intermittent motion, speeds can be in excess of the numbers shown.

## Performance Ratings (for Linear Motion)

Plain bearings are rated by their limiting PV, which is a combination of load over a given surface area and the velocity.

Bearing Material	MAX. "PV"	MAX. "P"	MAX. "V" (No Lubrication)
FrelonGOLD®	20000 (psi) x ft./min.)	3000 psi	300 sfm
	or 430 (kgf/cm <sup>2</sup> x m/min.)	or 210.9 kgf/cm <sup>2</sup>	or 91.44 m/min.
Frelon® J / Frelon® W	10000 (psi x ft./min.)	1500 psi	140 sfm
	or 215 (kgf/cm <sup>2</sup> x m/min.)	or 105.45 kgf/cm <sup>2</sup>	or 42.66 m/min.

**PV** = The performance measurement of plain bearings

**PV** = P x V where P = pressure (load) in psi (kgf/cm<sup>2</sup>)

**V** = velocity (speed) in sfm (m/min.)

**Note:** All three parameters must be met by an application for the bearing to perform properly.

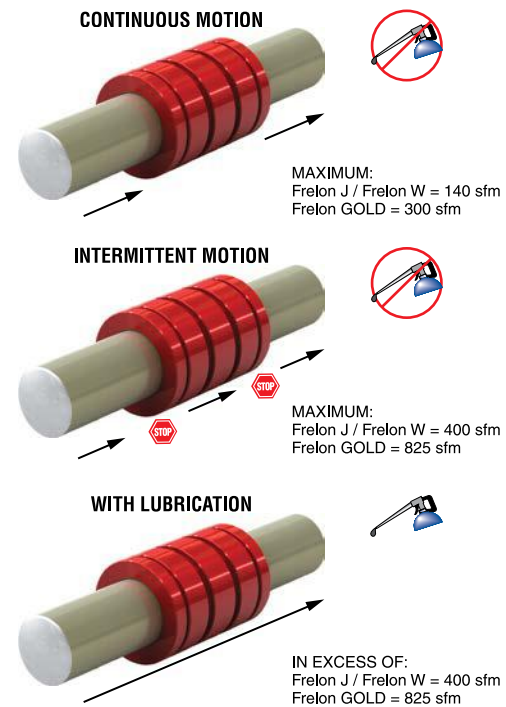

PERFORMANCE

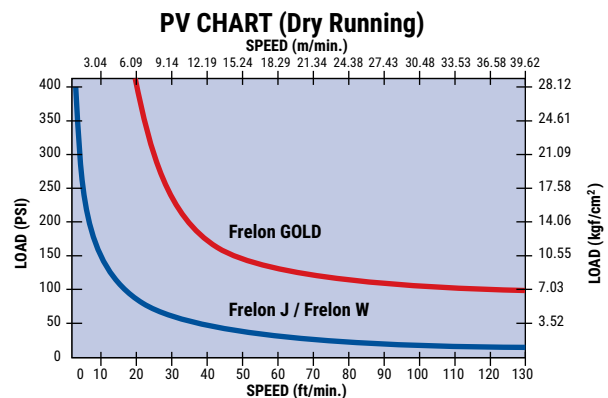

# Plain Bearings Simplicity®

## Wear Rate/Life Expectancy

The life expectancy of a Simplicity bearing is dependent on application parameters:

- Shaft hardness, surface finish, and preparation
- Length of travel
- Temperature
- Contamination
- Running clearance
- Lubrication
- Speed

The Radial Wear chart gives a guideline for a typical application at 10 psi (.703 kgf/cm<sup>2</sup>) traveling at 100 ft./min. (30.48 m/min.).

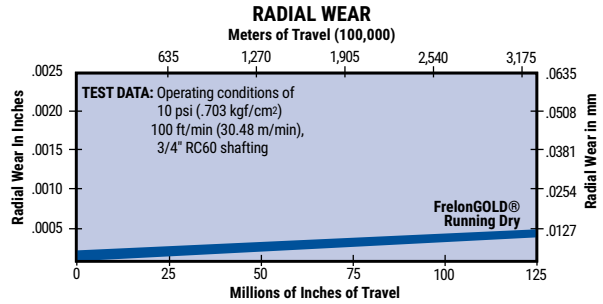

## Factors Affecting Wear Rate/Life

Shafting requirements for Frelon® bearing materials include:

### BEST PERFORMANCE:

- Finish of 8–12 Ra
- Hardness of RC 60

### ACCEPTABLE PERFORMANCE:

- Finish of 8–16 Ra
- Hardness of RC 35
- Surface finish requirements apply to all Frelon bearing materials
- Rougher shafting can be used, but both bearing and shafting will wear at accelerated rates and binding may occur

**Note:** Consult factory if using chrome plated shafting that is polished to < 8 Ra.

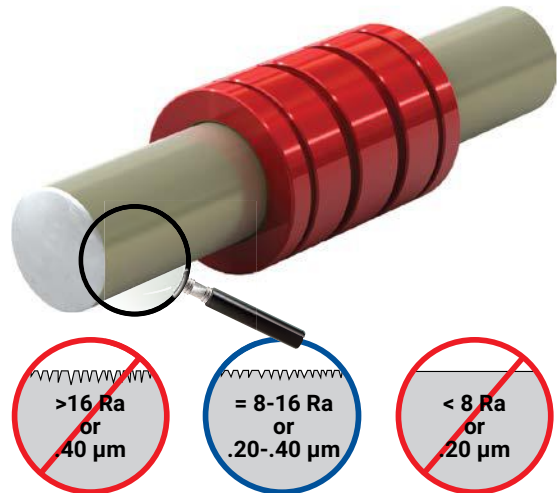

PERFORMANCE

## Cantilevered Loads

- Maximum 2:1 ratio
- 1x = bearing separation on same shaft
- 2x = distance from shaft to load or force

**Example:** If 2x equals 10" then 1x must be at least 5"

**CAUTION** Binding will occur if the 2:1 ratio is exceeded.

**2:1 Ratio Information**

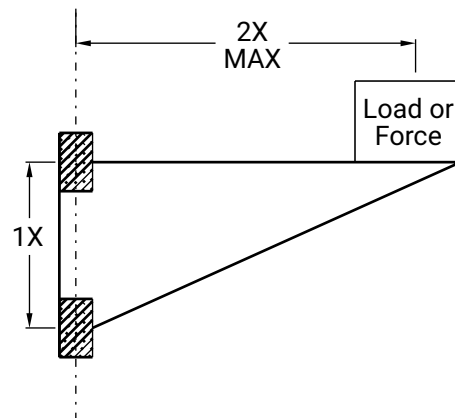

# Plain Bearings Simplicity®

## Transfer Process of Liner to Shaft

The interaction of the Frelon® material and the shafting creates a natural, microscopic transfer of the Frelon to the running surface. A thin film is deposited on the shaft, and the valleys in the surface finish are filled in with Frelon material during the initial break-in period. This transfer creates the self-lubricating condition of Frelon riding on Frelon.

This break-in period varies depending on several criteria:

1. Preparation of the shafting prior to installation – it is best to clean the shafting with a 3-in-1 type oil before installing the bearings. This ensures that the surface will receive a full transfer of material.
2. Speed, load, and length of stroke specific to the application – typically the initial transfer process will take approximately 50-100 strokes of continuous operation. The running clearance on the bearing will increase an average of 0.0002" to 0.0005", depending on the length of the stroke and surface requiring the transfer.
3. How often the shafting is cleaned – if the shafting is cleaned regularly, increased wear will be seen in the bearings. This is due to the transfer process being performed over and over again.

**CAUTION** Do not repeatedly clean the shafting with alcohol. This will remove the previously transferred material entirely and increase the wear to the bearing liner.

**CAUTION** Do not use smooth chrome shafting with Frelon bearings. The surface finish is less than 8 Ra and does not maintain proper transfer of Frelon material. This will result in accelerated wear.

## Lubrication

- Reduce friction up to 50%
- Minimize wear of liner
- Reduce heat buildup allowing greater speeds  
Actual speeds achieved are dependent on type of lubricant and frequency of application
- Aid in cleaning the shafting for a proper transfer process  
A minimum of initial lubrication of Simplicity bearings is strongly recommended

## Chemical Resistance

Simplicity bearings stand up to harsh environments and provide excellent performance in a submerged condition.

**FrelonGOLD®** – the fillers in the material can be attacked by deionized water and other harsh chemicals

**Frelon J** – almost universal chemical inertness: Only molten sodium and fluorine at elevated temperatures and pressures show any signs of attack

**Frelon W** – A white colored food-grade liner that is FDA compliant

**Anodized Aluminum Shell (Standard)** – good chemical resistance in most industrial applications

**316 Stainless Steel Shell (Optional)** – excellent chemical and corrosion resistance in harsh environments

Frelon Transfer Process

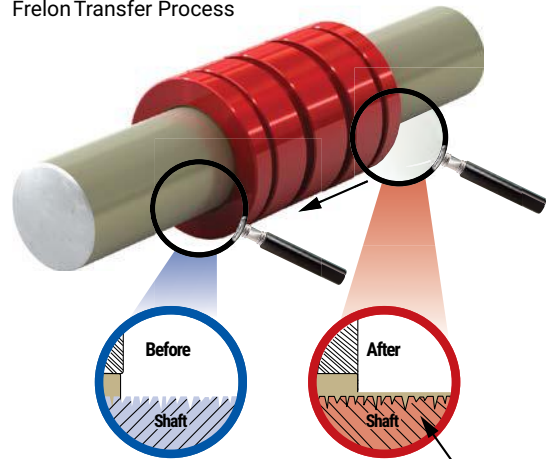

At break-in, Frelon deposits a microscopic film on the shaft and fills the valleys in the surface finish creating a Frelon-on-Frelon running condition that is true self-lubrication.

## RECOMMENDED LUBRICATION

- Waylube Oil
- Light Weight Oils
- Petroleum Based Grease
- 3-in-1 oils

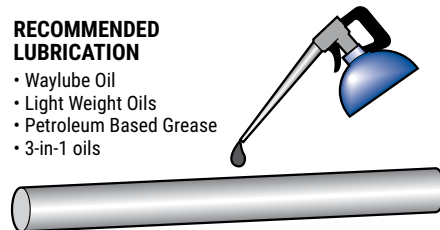

## NOT RECOMMENDED

- WD-40
- PTFE Sprays
- Fluorocarbons
- Silicon Oils, Grease or Spray

WD40® is a registered trademark of the WD40 company



More Information about Simplicity's Chemical Resistance

# Plain Bearings Simplicity®

## Temperature

Simplicity bearings can operate in a wide range of temperatures (-400°F to +400°F) (-240°C to +204°C). Depending on the materials housed in the pillow block and the size of bearing

- Maintains the same performance characteristics
- The thin liner allows heat to dissipate through the bearing shell

## Thermal Expansion

The standard bearing I.D. options are designed for use in most industrial applications.

For temperatures below 0°F, the standard I.D. is recommended (FL series).

For extreme high temperatures, the Compensated I.D. bearing is recommended (FLC) for the increased running clearance.

**CAUTION** It is always best to inspect actual size at extreme temperatures to ensure proper running clearance.

## Rotary Applications

Simplicity bearings will operate very well in rotary applications if applied properly.

Stationary rotary applications do not allow the heat to be spread over an extended area. It is retained in the I.D. of the bearing limiting speed and load.

- MAX rotary speed (No lube/continuous motion)
- 40 sfm (12.2 m/min.) for standard precision I.D. clearances
- 140 sfm (42.6 m/min.) for compensated I.D. clearances

$$V(\text{sfm}) = 0.262 \times d \times \text{RPM}$$

$d$  = shaft diameter (inches)  
RPM = revolutions per minute

- Properly maintained lubrication can increase these speeds dramatically

**CAUTION** It is always best to do specific testing for rotary applications above these limits where lubrication is to be used.

## Vacuums/Outgassing/Cleanrooms

Due to self-lubrication, low outgassing, and a minimum of particulate (buildup), Simplicity bearings are excellent in clean rooms and vacuums.

Testing has been done on the Frelon® materials in accordance with ASTM E-595-90 with acceptable maximums of 1.00% TML and 0.10% CVCM.

MATERIAL	%TML	%CVCM
FrelonGOLD®	0.00	0.00
Frelon J	0.18	0.01

**TML** = Total Mass Loss  
**CVCM** = Collected Volatile Condensable Materials

## Temperature Extremes

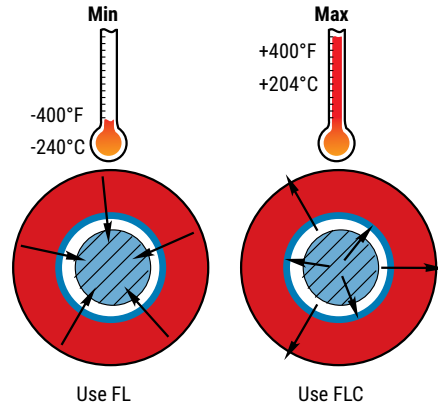

## Maximum Rotary Speeds

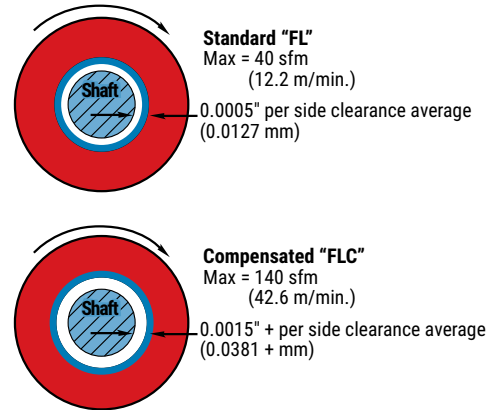

## Submerged Applications

Simplicity bearings will provide excellent performance in a submerged condition.

The bearings will employ the fluid as a lubricant showing increased velocities and wear life. Oils and non-salt water are especially effective.

**Note:** Please contact factory before specifying FrelonGOLD for submerged applications.

# Plain Bearings Simplicity®

## O-Rings

Used in standard pillow blocks and with self-aligning bearings.

**Nitrile Buna 70 (standard)** – A good general purpose rubber that is used in 98% of applications (-65°F to 275°F (-54°C to 135°C)).

**Viton (special – designate with “V”)** – Used only in high temperature applications up to 400°F (up to 204°C).



## Seals

Use only in the most contaminated environments.

**Polymod® (standard)** – A high performance polymer modified material that reduces friction of a standard buna material by 50% and increases wear life.

Polymod is a registered trademark of Polymod Technologies, Inc.

**Temperature:** -20°F to +212°F

**Urethane (special - designate with “U”)** – A moly-impregnated urethane scraper that is only for the severest applications - friction is greatly increased!

**Temperature:** -40 to +200°F

**Viton™ (special - designate with “V”)** – A brand of synthetic rubber and fluoropolymer elastomer used only in high temperature applications.

**Temperature:** Up to +400°F

**Attention:** 90% of applications do not require seals when using Simplicity bearings. The liner has a natural ability to wipe particles from the shafting. Any particulate (metal, sand, etc.) that does enter the bearing will embed itself into the soft liner not scoring the shafting or locking mechanical parts.

When ordering a bearing with any internal features (seals or internal lubrication), the bearing may or may not be shipped with extra internal grooves in addition to those needed for the ordered option. Low volume orders are more likely to have additional grooves. The extra grooves will not negatively impact the performance of the bearing.

Also, internal grooves are typically an anodized surface; however, in the interest of the quickest possible delivery, the internal grooves may not be anodized.

## Lubrication System

Order with “JKM” modifier

**Lubrication system includes:**

**Felt wick** – Retains oil lubricants (remove when using grease lubrication). Wicks are glued in place on open bearings while they just sit in place on closed bearings.

**Zerk fitting** – Installed into pillow block, other housing, or directly into die sets PAC, PACM. (Standard lube fitting with ¼-28 thread)

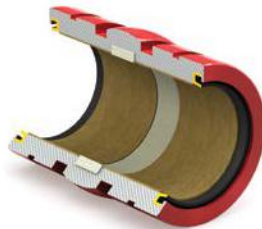

### ZERK FITTING IN HOUSING

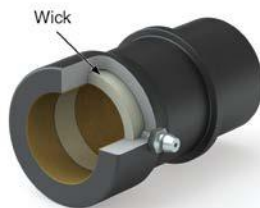
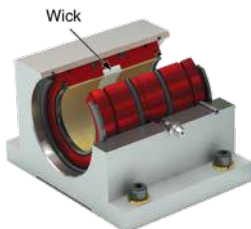

## Bearing Alignment

Linear ball bearings will continue to operate in a misaligned condition, but can cause damage to the shafting and catastrophically fail.

Simplicity bearings DO NOT tolerate misalignment. They simply stop moving without any damage to the shafting. Self-aligning housings aid in misalignment – up to 1/2° from centerline.

**Note:** Please refer to the tables in the installation section for possible solutions to misalignment.



**Misalignment Considerations—page 150**

# Applications

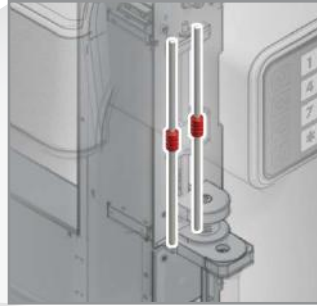
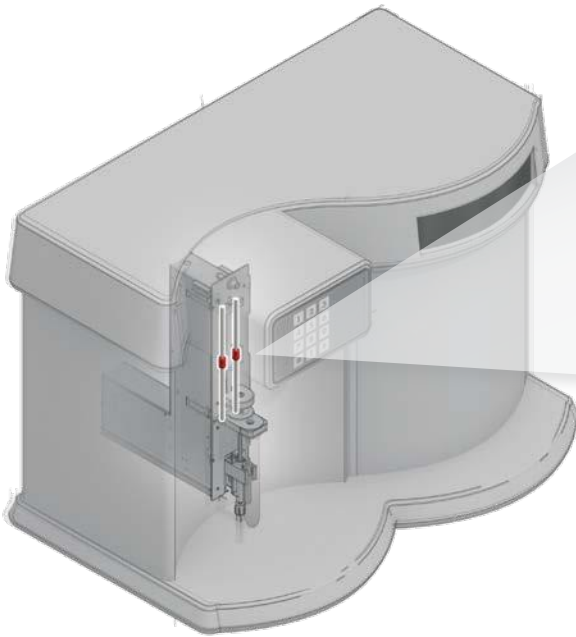

**LAB EQUIPMENT:** This blood analyzer utilizes Simplicity® plain bearings because they are self-lubricating and do not require additional grease, which can cause contamination.

**PRINTING:** Commercial printers, 3D printers, laser printers, and deskjets all require smooth, precise, and quiet linear motion, which Simplicity linear plain bearings provide.

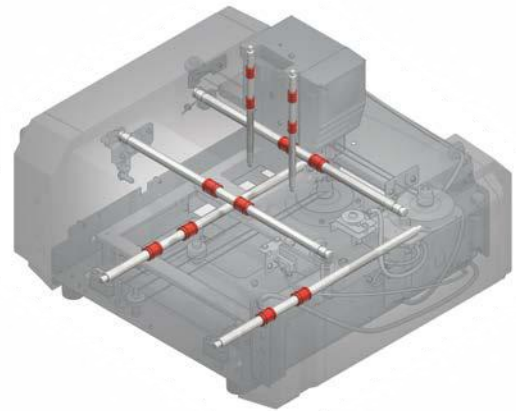

**THERMOFORMING:** Simplicity linear plain bearings operate in a wide range of temperatures, which is required when molding heated plastic sheeting in thermoforming machines.

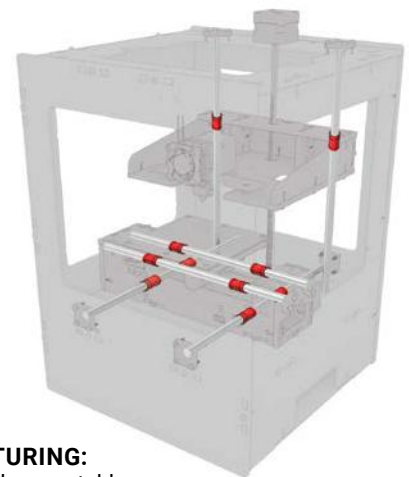
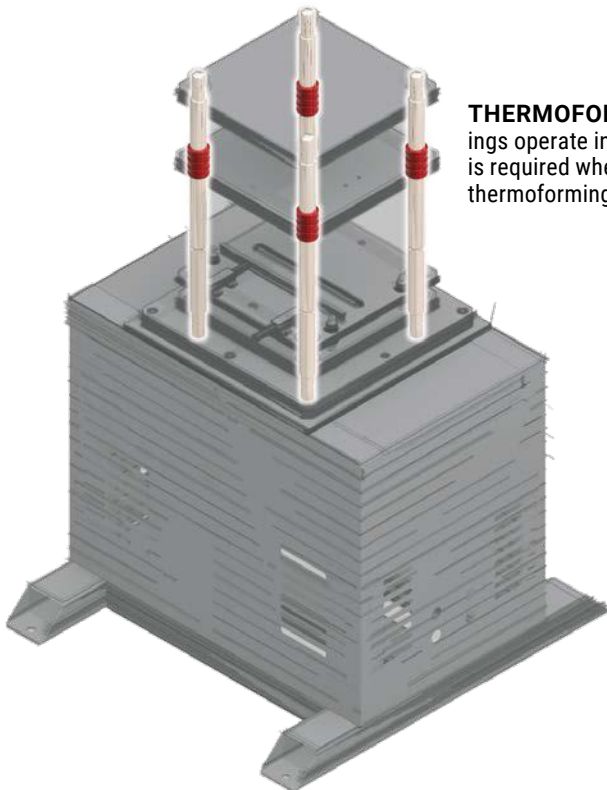

**ADDITIVE MANUFACTURING:** 3D printers require smooth, repeatable linear motion, which is achieved with Frelon®-lined linear plain bearings.

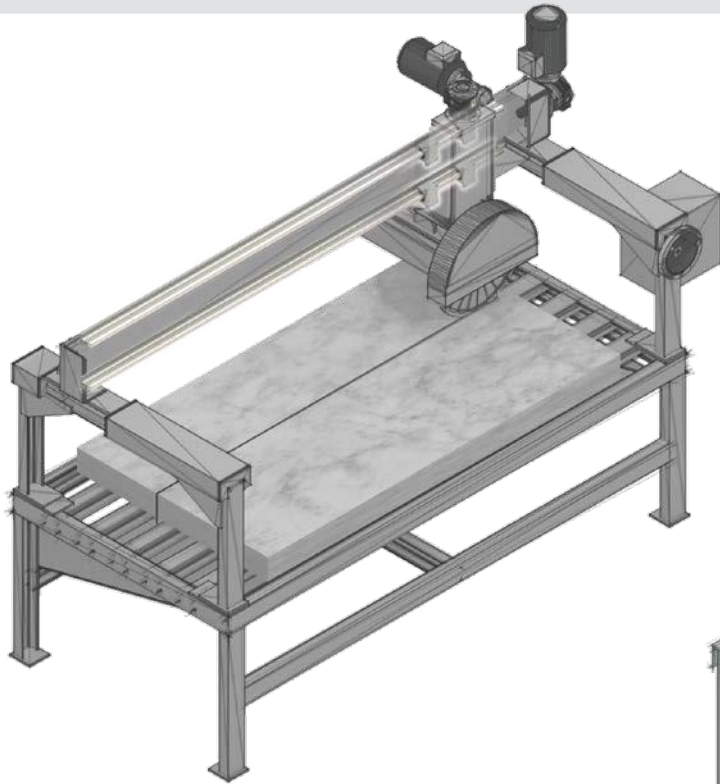

**STONE SAWS & HEAVY DUTY CUTTERS:** Simplicity® linear plain bearings are self lubricating and excel in dirty or contaminated environments such as saws and cutters.

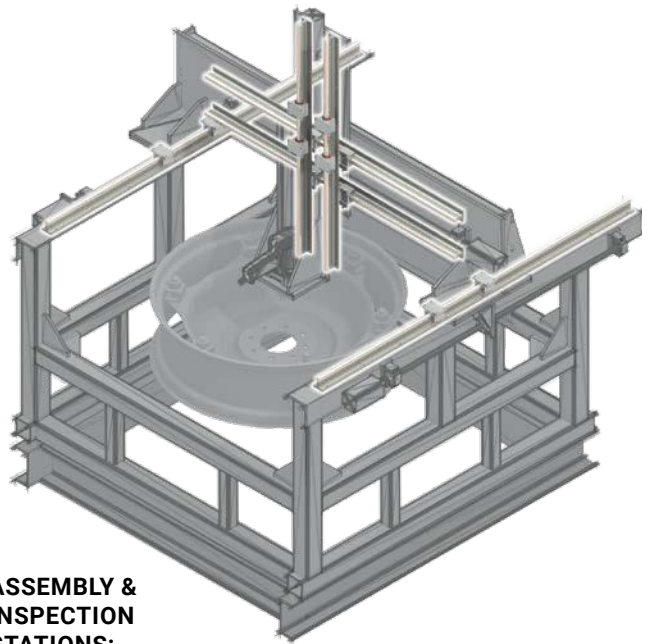

**ASSEMBLY & INSPECTION STATIONS:** Round Shaft Technology utilizes precision round shafting as a guideway and combines linear plain or ball bearings for movement – providing a low maintenance solution in assembly stations.

**SEAT ADJUSTMENT & SHOCK ABSORPTION:** Not all applications are easily accessible for maintenance or repair, including tough military vehicle seating. This is one reason Simplicity plain bearings, with Frelon® self-lubricating liner, is the best choice. Simplicity provides long-lasting linear motion that will not catastrophically fail.



**WELDING MACHINES:** Simplicity linear bearings handle loads over 700 kN (157,000 lb.) and have a high temperature range (up to 204°C). As required in welding applications, they require low maintenance in contaminated environments.

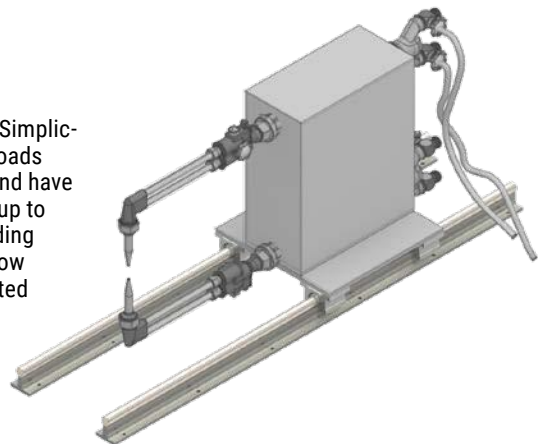

# Ordering Information Plain Bearings



Configure  
Online

## Plain Bearings

### Series

**FL** - Standard Inch Series  
**FLR** - Supergroove Interchange  
 Available only with **FL06, 08, 12, 16**

**FM** - ISO Metric Series  
**FMT** - Compact ISO Metric Thin Wall Series  
**FG** - "FAG™" Thin Wall Interchange

**FJ** - JIS Standard Series

**PS** - Inch Series Sleeve Bearings  
**PSF** - Inch Series Flange Bearings

**PSM** - ISO Metric Series Sleeve Bearings  
**PSFM** - ISO Metric Series Flange Bearings

### O.D. Features

**No Entry** - Standard straight O.D. bearing  
**A** - Crowned "self-aligning" O.D. bearing (closed only)  
 Available only on **FL, FM, FJ** series

### I.D. Features

**No Entry** - Standard precision running clearance on the I.D.  
**C** - Compensated running clearance on the I.D.  
 Does NOT apply to **PS, PSF, PSM, PSFM**

### Closed or Open Style

**No Entry** - Standard closed bearing  
**N** - Open series bearing (not available in **FLA, FMA, and FJA**)  
 Available only on **FL, FM, FJ** series

### Bearing Shell Material

Available ONLY on the **FL, FM, FMT, FG, FJ** series  
**No Entry** - Standard aluminum alloy  
**\*S** - 316 Stainless Steel  
 \*Made to order. No finish plating or anodize available.

### Nominal Shaft Diameter

English units in 16ths of an inch  
 Metric units in mm

**FL A C N S 16 - D E JKM Q**

### Seal Options

**D** - Double seals of standard Polymod® material  
**DU** - Double seals of moly impregnated urethane material  
**DV** - Double seals of viton - high temperature material  
 D, DU, and DV seals available with **FL08-FL32**  
 DU seals available with **FM20-FM80, FJ20-FJ120**

### Bearing Liner Material

**No Entry** - Standard Frelon GOLD® liner for hardened steel, ceramic coated, and 400 series stainless steel shafting  
**\*E** - Frelon J® liner for soft shafting (aluminum, 300 series stainless steel, etc.)  
 \* Limited availability may require special quote  
**W** - Food grade liner (contact PBC Linear before ordering)

### Internal Lubrication

**No Entry** - Standard bearing - No lube system  
**JKM** - Thru hole, and internal felt wick to help lubrication retention and flow.  
 JKM available with **FL08-FL64, FM12-FM80, FJ20-FJ150**

### Special Modifications

**No Entry** - Standard Options  
**Q** - Shipped Oil Free  
 (contact PBC Linear before ordering)



Only certified Simplicity 60 Plus Shafting provides maximum linear bearing performance.

Inch Series—page 52 Metric Series—page 90

ORDERING

The data and specifications in this publication have been carefully compiled and are believed to be accurate and correct. However, it is the responsibility of the user to determine and ensure the suitability of PBC Linear® products for a specific application. PBC Linear's only obligation will be to repair or replace without charge, any defective components if returned promptly. No liability is assumed beyond such replacement. Specifications are subject to change without notice. Consult www.pblinear.com for the latest technical updates.

# Ordering Information Plain Bearings

## Plain Bearings With Housings



Configure  
Online

### Series

- P** - Standard Inch Pillow Blocks (FL)
- PW** - Inch Twin Pillow Blocks (FL)
- PM** - ISO Metric Pillow Blocks (FM)
- SFP** - Inch Single Flange Mounts (FL)
- DFP** - Inch Double Flange Mounts (FL)
- SDSZ** - Single Flange Mount Die Set (FLA)
- DDSZ** - Double Flange Mount Die Set (FLA)
- PACZ** - Inch Die Set Bearings
- PACMZ** - ISO Metric Die Set Bearings
- SFPM** - ISO Metric Single Flange Bearings
- DFPM** - ISO Metric Double Flange Bearings
- CFPM** - ISO Metric Double Center Flange Bearings
- SFPJ** - JIS Metric Single Flange Bearings
- DFPJ** - JIS Metric Double Flange Bearings
- CFPJ** - JIS Metric Double Center Flange Bearings

**Note:** Standard Simplicity® bearings are installed in housings.

Metric flange bearings do not have bearing inserts

### Closed or Open Style

- No Entry** - Standard Closed Series
- N** - Open Series

Available only on **P**, **PW**, **PM** series

### Housing I.D. Features

**No Entry** - Standard spherical "self-aligning" I.D. in the housing. (Uses standard straight O.D. bearings.)

**B** - Straight I.D. housing. (For rigid fit use standard bearing. For self-alignment use FLA bearings.)

Available only on **P**, **PW**, **PM**, **SFP**, **DFP**, **SDS**, **DDS** series

**No Entry** - Standard Square Flange

**R** - Round Flange

Available only on **SFPM**, **DFPM**, **CFPM**, **SFPJ**, **DFPJ**, **CFPJ** series

### Housings Only

- No Entry** - Housings with bearing included
- E** - Empty Housings with NO bearing included

### Material

**Z** - Aluminum, Available only on **PAC/PACM** Diesets

**Note:** Steel no longer offered

**S** - SST Pillow Blocks (use **FLA** BRG, PB, Retainer)

### Nominal Shaft Diameter

English units in 16ths of an inch  
Metric units in mm



### Bearing I.D. Features

- No Entry** - Standard Precision running clearance on the I.D.
- C** - Compensated running clearance on the I.D.

### Seal Options

- D** - Double seals of standard Polymod® material
- DU** - Double seals of moly impregnated urethane material
- DV** - Double seals of viton - high temperature material

**PAC** and **PACM** available only as:

- S** - Single seals of standard Polymod® material
- SU** - Single seals of moly impregnated urethane material
- SV** - Single seals of viton - high temperature material

### Bearing Liner Material

**No Entry** - Standard Frelon GOLD® liner for hardened steel or ceramic coated aluminum

**\*E** - Special Frelon J® liner for soft shafting (aluminum, 300 series stainless steel, etc.)

\* Limited availability may require special quote

**W** - Food grade liner (contact PBC Linear before ordering)

### Internal Lubrication

**No Entry** - Standard pillowblock assembly with no lubrication system

**JKM** - Thru holes and internal felt wick to help lubrication retention and flow 1/4-28 Zerk

**Note:** Zerk fitting installed into pillow block, other housing, or directly into die sets **PAC** & **PACM**.

### Special Modifications

**No Entry** - Standard Options

**Q** - Shipped Oil Free

(contact PBC Linear before ordering)



**Only certified Simplicity 60 Plus Shafting provides maximum linear bearing performance.**

**Inch Series—page 52 Metric Series—page 90**

ORDERING

This catalog and part numbering system is designed to represent all possibilities which may not be standard parts. These are options only—combinations could lead to unavailable parts. Contact PBC Linear at 800-962-8979 for information.

# Simplicity® Linear Plain Bearings

INCH

ISO METRIC

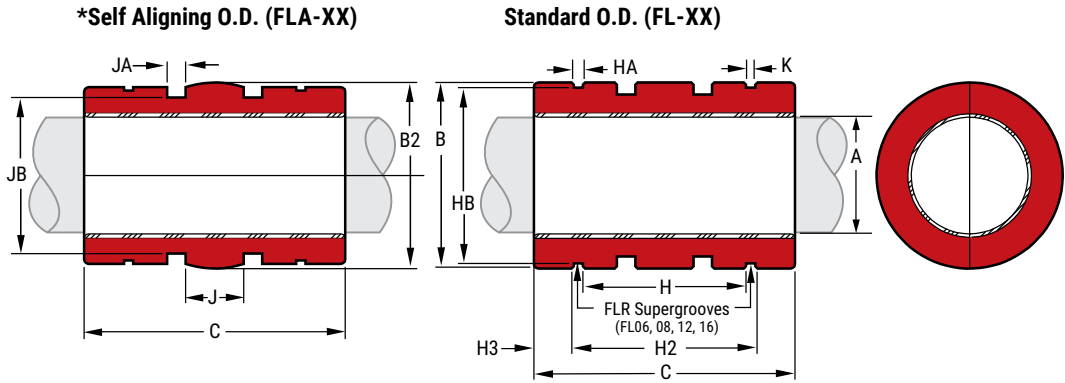

\*Except for the O.D., bearings with the self-aligning feature have the same dimensions and tolerances as the standard bearing. There is a spherical crown on the O.D. to create the self-aligning feature. They are for use in a straight bore housing. Add an "A" to the part number for self-aligning bearings.

## DIMENSIONAL INFORMATION

Precision I.D. Series Similar to Preloaded Ball Bearing				Compensated I.D. Series Allows additional Running Clearance				Nominal Size	B Standard O.D.		b2 Self-Aligning FLA Crown O.D.		C Length		Con-centric MAX.	Bearing Weight lb.	K FLR Ret. Ring Grv.
Part No.		A Bearing I.D.		Part No.		A Bearing I.D.			MIN.	MAX.	MIN.	MAX.	MIN.	MAX.			
Closed	Open	MIN.	MAX.	closed	open	MIN.	MAX.	in.	MIN.	MAX.	MIN.	MAX.	MIN.	MAX.			
FL 03	N/A	0.1877	0.1884	FLC 03	N/A	0.1897	0.1904	3/16	0.3740	0.3750	0.3725	0.3735	0.5470	0.5620	0.0010	0.0030	N/A
FL 04	FLN 04	0.2502	0.2511	FCL 04	FLCN 04	0.2522	0.2531	1/4	0.4990	0.5000	0.4975	0.4985	0.7350	0.7500	0.0010	0.0090	N/A
FL 06	FLN 06	0.3752	0.3761	FCL 06	FLCN 06	0.3772	0.3781	3/8	0.6240	0.6250	0.6225	0.6235	0.8600	0.8750	0.0010	0.0160	0.0720
FL 08	FLN 08	0.5002	0.5013	FCL 08	FLCN 08	0.5022	0.5033	1/2	0.8740	0.8750	0.8725	0.8735	1.2350	1.2500	0.0010	0.0410	0.0800
FL 10	FLN 10	0.6252	0.6263	FCL 10	FLCN 10	0.6272	0.6283	5/8	1.1240	1.1250	1.1225	1.1235	1.4850	1.5000	0.0010	0.0910	N/A
FL 12	FLN 12	0.7503	0.7516	FCL 12	FLCN 12	0.7533	0.7546	3/4	1.2490	1.2500	1.2475	1.2485	1.6100	1.6250	0.0010	0.1090	0.1710
FL 16	FLN 16	1.0003	1.0016	FCL 16	FLCN 16	1.0033	1.0046	1	1.5613	1.5625	1.5599	1.5609	2.2350	2.2500	0.0010	0.2280	0.1330
FL 20	FLN 20	1.2504	1.2519	FCL 20	FLCN 20	1.2544	1.2559	1-1/4	1.9988	2.0000	1.9974	1.9984	2.6100	2.6250	0.0010	0.4590	N/A
FL 24	FLN 24	1.5004	1.5019	FCL 24	FLCN 24	1.5044	1.5059	1-1/2	2.3738	2.3750	2.3724	2.3734	2.9850	3.0000	0.0010	0.7250	N/A
FL 32	FLN 32	2.0004	2.0022	FCL 32	FLCN 32	2.0054	2.0072	2	2.9986	3.0000	2.9973	2.9983	3.9850	4.0000	0.0010	1.4420	N/A
FL 40	FLN 40	2.5004	2.5022	FCL 40	FLCN 40	2.5054	2.5072	2-1/2	3.7484	3.7500	3.7472	3.7482	4.9850	5.0000	0.0013	2.8160	N/A
FL 48	FLN 48	3.0004	3.0022	FCL 48	FLCN 48	3.0064	3.0082	3	4.4980	4.5000	4.4970	4.4980	5.9850	6.0000	0.0015	4.9140	N/A
FL 64	FLN 64	4.0005	4.0026	FCL 64	FLCN 64	4.0065	4.0086	4	5.9980	6.0000	5.9970	5.9980	7.9850	8.0000	0.0020	11.8360	N/A

## MOUNTING DIMENSIONS

Part No.		Nominal Size in.	H	HA	HB	Truarc Ret. Ring Part No.	J	JA	JB	Parker O'Ring Part No.	H2	H3
Closed	Open		Between Ret. Rings	Ret. Ring Grv. Width	Ret. Ring Grv. Dia.		Between O'Ring Grvs.	O'Ring Grv. Width	O'Ring Grv. Dia.		FLR Between Rings	FLR Ring Edge
FL 03	N/A	3/16	0.375	0.030	0.352	N 5100-37	N/A	N/A	N/A	N/A	N/A	N/A
FL 04	FLN 04	1/4	0.437	0.041	0.467	N 5100-50	0.125	0.080	0.399	2-010	N/A	N/A
FL 06	FLN 06	3/8	0.562	0.041	0.587	N 5100-62	0.187	0.080	0.524	2-012	0.711/0.701	0.112
FL 08	FLN 08	1/2	0.875	0.048	0.820	N 5100-87	0.250	0.125	0.712	2-113	1.042/1.032	0.135
FL 10	FLN 10	5/8	1.000	0.058	1.060	N 5100-112	0.312	0.125	0.962	2-117	N/A	N/A
FL 12	FLN 12	3/4	1.062	0.058	1.177	N 5100-125	0.312	0.125	1.087	2-119	1.281/1.271	0.220
FL 16	FLN 16	1	1.625	0.070	1.471	N 5100-156	0.500	0.125	1.399	2-123	1.895/1.885	0.239
FL 20	FLN 20	1-1/4	1.875	0.070	1.889	N 5100-200	0.625	0.125	1.837	2-129	N/A	N/A
FL 24	FLN 24	1-1/2	2.250	0.089	2.241	N 5100-237	0.750	0.162	2.152	2-225	N/A	N/A
FL 32	FLN 32	2	3.000	0.105	2.839	N 5100-300	1.000	0.189	2.775	2-229	N/A	N/A
FL 40	FLN 40	2-1/2	3.750	0.123	3.553	N 5100-375	1.250	0.250	3.408	2-340	N/A	N/A
FL 48	FLN 48	3	4.500	0.123	4.309	N 5100-450	1.500	0.287	4.158	2-346	N/A	N/A
FL 64	FLN 64	4	6.000	0.145	5.748	N 5100-600	2.000	0.287	5.660	2-356	N/A	N/A

Note: FLR is only available on FL06, FL08, FL12 and FL16.

# Simplicity® Linear Plain Bearings

## Linear Plain Bearings FL & FLN

### FLN 04 - FLN 06

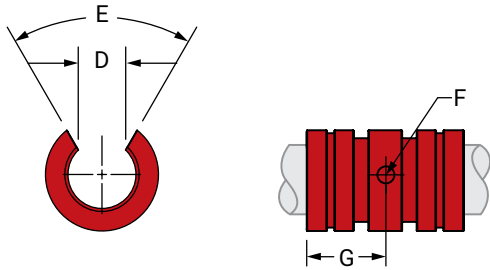

### FLN 08

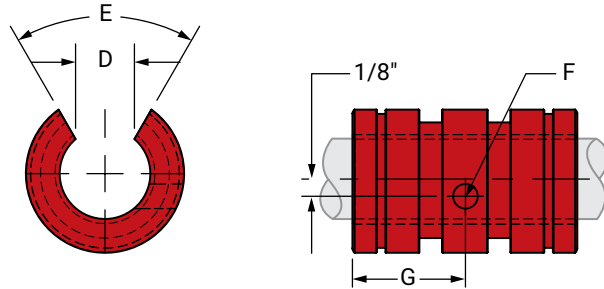

### FLN 10

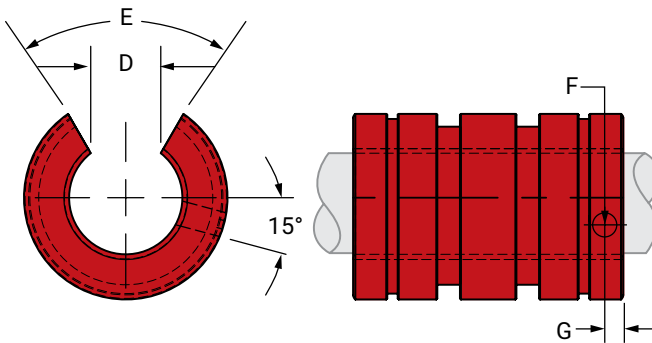

### FLN 12 THRU FLN 64

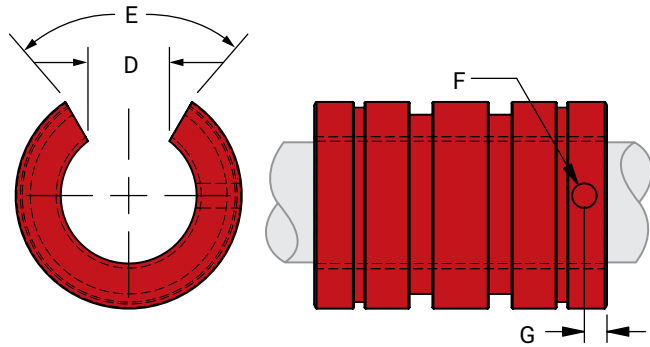

## OPEN DIMENSIONAL INFORMATION

Part No.		Nominal Size	D Slot Wide MIN.	E Slot Angle	F Retaining Hole Dia.	G Retaining Hole Locate	Bearing Weight
Precision	Compensated	in.				in.	lb.
FLN 04	FLCN 04	1/4	0.188	60°	0.094	3/8	0.008
FLN 06	FLCN 06	3/8	0.250	60°	0.094	7/16	0.013
FLN 08	FLCN 08	1/2	0.313	60°	0.136	5/8	0.034
FLN 10	FLCN 10	5/8	0.375	60°	0.136	1/8	0.072
FLN 12	FLCN 12	3/4	0.438	60°	0.136	1/8	0.091
FLN 16	FLCN 16	1	0.563	60°	0.136	1/8	0.184
FLN 20	FLCN 20	1-1/4	0.625	60°	0.201	3/16	0.381
FLN 24	FLCN 24	1-1/2	0.750	60°	0.201	3/16	0.603
FLN 32	FLCN 32	2	1.000	60°	0.265	5/16	1.192
FLN 40	FLCN 40	2-1/2	1.250	60°	0.265	5/16	2.334
FLN 48	FLCN 48	3	1.500	60°	0.265	5/16	4.080
FLN 64	FLCN 64	4	2.000	60°	0.265	5/16	9.870

Note: All other dimensions same as closed bearing. FrelonGOLD® and Frelon® J are registered trademarks of PBC Linear®.



**Plain Bearing Accessories:**  
Retaining Rings, Seals, O-Rings—page 19



**Only certified Simplicity 60 Plus Shafting provides maximum linear bearing performance.**

**Inch Series—page 52 Metric Series—page 90**

## LOAD & SPEED DATA

Part No.	Effective Surface Area	MAX. Static Load lb.	
		Frelon GOLD	J & W
FL 03	0.110	220	100
FL 04	0.200	600	300
FL 06	0.340	1020	510
FL 08	0.650	1950	975
FL 10	0.980	2940	1470
FL 12	1.270	3810	1905
FL 16	2.350	7050	3525
FL 20	3.430	10830	5415
FL 24	4.700	14100	7050
FL 32	8.350	25050	12525
FL40	13.000	39000	19500
FL 48	18.800	56400	28200
FL 64	33.500	100500	50250

Note: MAX PV (ft./min. \* psi)  
FrelonGOLD = 20000 PV Frelon J = 10000 PV

MAX Speed Running Dry (ft./min.)  
FrelonGOLD = 300 sfm Frelon J = 140 sfm

MAX Speed Running with Lubrication (ft./min.)  
FrelonGOLD = 825 sfm Frelon J = 400 sfm

# Simplicity® Pillow Blocks

## Plain Bearings – Closed Pillow Blocks P

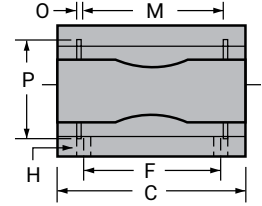
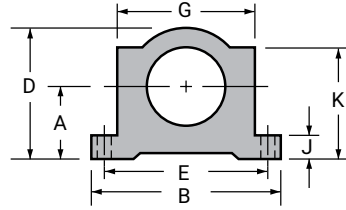
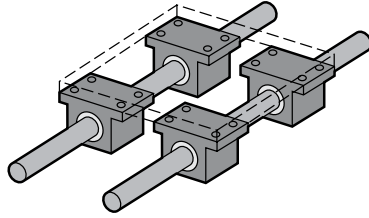

Part No.		Nom. Brg. I.D.	A	B	C	D	E	F	G	H		J		M		O	P	Retaining Ring Part No.	MAX Static Load lb.		Assem. WT.
Precision	Compensated									Bolt	Hole	Thick	k	Space	Width				Dia.	FRELON®	
P 04	P 04C	1/4	0.437	1.625	1.19	0.813	1.312	0.750	1.000	#6	5/32"	0.188	0.750	0.750	0.039	0.532	6010026	600	300	0.099	
P 06	P 06C	3/8	0.500	1.750	1.31	0.938	1.437	0.875	1.125	#6	5/32"	0.188	0.875	0.875	0.039	0.665	6010027	1020	510	0.129	
P 08	P 08C	1/2	0.687	2.000	1.69	1.250	1.688	1.000	1.375	#6	5/32"	0.250	1.125	1.250	0.046	0.931	6010028	1950	975	0.250	
P 10	P 10C	5/8	0.875	2.500	1.94	1.625	2.125	1.125	1.750	#8	3/16"	0.281	1.438	1.500	0.056	1.197	6010029	2940	1470	0.500	
P 12	P 12C	3/4	0.937	2.750	2.06	1.750	2.375	1.250	1.875	#8	3/16"	0.313	1.563	1.625	0.056	1.330	6010030	3710	1905	0.580	
P 16	P 16C	1	1.187	3.250	2.81	2.188	2.875	1.750	2.375	#10	7/32"	0.375	1.938	2.250	0.068	1.671	6010031	7050	3525	1.000	
P 20	P 20C	1-1/4	1.500	4.000	3.63	2.813	3.500	2.000	3.000	#10	7/32"	0.438	2.500	2.625	0.068	2.122	6010032	10290	5145	2.000	
P 24	P 24C	1-1/2	1.750	4.750	4.00	3.250	4.125	2.500	3.500	1/4"	9/32"	0.500	2.875	3.000	0.086	2.519	6010033	14100	7050	3.000	
P 32	P 32C	2	2.125	6.000	5.00	4.063	5.250	3.250	4.500	3/8"	13/32"	0.625	3.625	4.000	0.103	3.182	6010034	25050	12525	6.500	

- Notes:** (1) Standard, pre-assembled pillow blocks include self-aligning housing and precision bearing.  
 (2) All standard pillow blocks use standard FL series bearings.  
 (3) Straight bore, pre-assembled pillow blocks use standard FL series bearings.

## Plain Bearings – Open Pillow Blocks PN

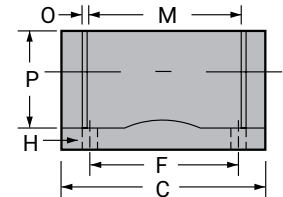
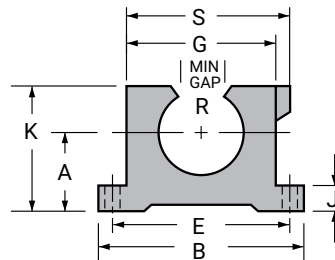
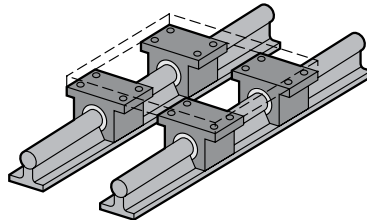

Part No.		Nom. Brg. I.d.	A	B	C	E	F	G	H		J		M		O	P	R	Retaining Ring Part No.	MAX. Static Load lb.		Assem. WT.	S
Precision	Compensated								Bolt	Hole	Thick	Height	Space	Width					Dia.	Open		
PN 08	PN 08C	1/2	0.687	2.000	1.50	1.688	1.000	1.375	#6	5/32"	0.250	1.125	1.250	0.046	0.931	0.313	6010035	1950	975	0.250	1.438	
PN 10	PN 10C	5/8	0.875	2.500	1.75	2.125	1.125	1.750	#8	3/16"	0.281	1.438	1.500	0.056	1.197	0.375	6010036	2940	1470	0.500	1.813	
PN 12	PN 12C	3/4	0.937	2.750	1.88	2.375	1.250	1.875	#8	3/16"	0.313	1.563	1.625	0.056	1.330	0.438	6010037	3710	1905	0.580	1.938	
PN 16	PN 16C	1	1.187	3.250	2.63	2.875	1.750	2.375	#10	7/32"	0.375	1.938	2.250	0.068	1.671	0.563	6010038	7050	3525	1.000	2.438	
PN 20	PN 20C	1-1/4	1.500	4.000	3.38	3.500	2.000	3.000	#10	7/32"	0.438	2.500	2.625	0.068	2.122	0.625	6010039	10290	5145	2.000	3.125	
PN 24	PN 24C	1-1/2	1.750	4.750	3.75	4.125	2.500	3.500	1/4"	9/32"	0.500	2.875	3.000	0.086	2.519	0.750	6010040	14100	7050	3.000	3.625	
PN 32	PN 32C	2	2.125	6.000	4.75	5.250	3.250	4.500	3/8"	13/32"	0.625	3.625	4.000	0.103	3.182	1.000	6010041	25050	12525	6.500	4.688	

- Notes:** (1) Standard, pre-assembled pillow blocks include self-aligning housing and precision bearing.  
 (2) All standard pillow blocks use standard FL series bearings.

 **Simplicity Linear Slides: Pre-Assembled Pillow Block, Shaft, and Support Rail—page 108**



**Only certified Simplicity 60 Plus Shafting provides maximum linear bearing performance.**

**Inch Series—page 52 Metric Series—page 90**

# Simplicity® Twin Pillow Blocks

## Plain Bearings – Closed Twin Pillow Blocks PW

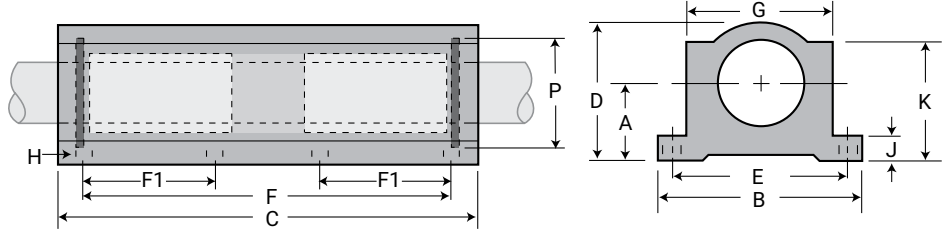

Part No.		Nom. Brg. I.D.	A	B	C	D	E	F	F1	G	H		J		P	Retaining Ring Part No.	Max Static Load lb.		Assem. WT.
Precision	Compensated										Centerline	Width	Length	Height			+/- 0.010	+/- 0.010	
PW 04	PW 04C	1/4	0.437	1.625	2.500	0.813	1.3120	2.0000	0.750	1.000	#6	5/32"	0.188	0.750	0.532	6010026	1200	600	0.197
PW 06	PW 06C	3/8	0.500	1.750	2.750	0.938	1.4370	2.2500	0.875	1.125	#6	5/32"	0.188	0.875	0.665	6010027	2040	1020	0.258
PW 08	PW 08C	1/2	0.687	2.000	3.500	1.250	1.6880	2.5000	1.000	1.375	#6	5/32"	0.250	1.125	0.931	6010028	3900	1950	0.500
PW 10	PW 10C	5/8	0.875	2.500	4.000	1.625	2.1250	3.0000	1.125	1.750	#8	3/16"	0.281	1.438	1.197	6010029	5880	2940	1.000
PW 12	PW 12C	3/4	0.937	2.750	4.500	1.750	2.3750	3.5000	1.250	1.875	#8	3/16"	0.313	1.563	1.330	6010030	7620	3810	1.125
PW 16	PW 16C	1	1.187	3.250	6.000	2.188	2.8750	4.5000	1.750	2.375	#10	7/32"	0.375	1.938	1.671	6010031	14100	7050	2.188
PW 20	PW 20C	1-1/4	1.500	4.000	7.500	2.813	3.5000	5.5000	2.000	3.000	#10	7/32"	0.438	2.500	2.122	6010032	20580	10290	4.250
PW 24	PW 24C	1-1/2	1.750	4.750	9.000	3.250	4.1250	6.5000	2.500	3.500	1/4"	9/32"	0.500	2.875	2.519	6010033	28200	14100	6.375
PW 32	PW 32C	2	2.125	6.000	10.000	4.063	5.2500	8.2500	3.250	4.500	3/8"	13/32"	0.625	3.625	3.182	6010034	50100	25050	13.500

- Notes:** (1) Standard, pre-assembled pillow blocks include self-aligning housing and precision bearing.  
 (2) All standard pillow blocks use standard FL series bearings.  
 (3) Twin Closed Pillow Blocks use a spacer to separate the bearings.  
 (4) Twin pillow blocks, closed, with no seal option: Use two standard bearings, based on compensated or standard option.  
 (5) Twin pillow blocks, closed, with double seal option: Use two single seal bearings.

## Plain Bearings – Open Twin Pillow Blocks PWN

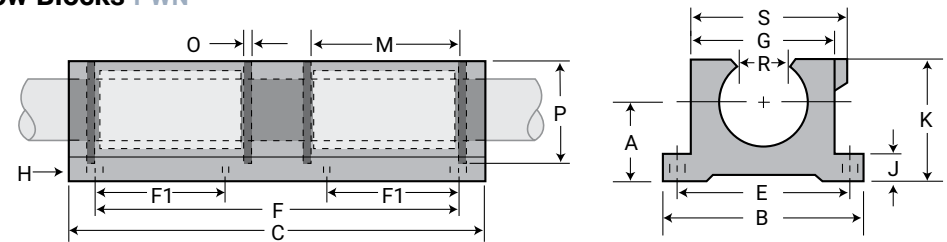

Part No.		Nom. Brg. I.D.	A	B	C	E	F	F1	G	H		J	K	M	O	P	R	Retaining Ring Part No.	MAX. Static Load lb.		Assem. WT.	S
Precision	Compensated									Centerline	Width								Length	+/- 0.010		
PWN 08	PWN 08C	1/2	0.687	2.000	3.500	1.688	2.500	1.000	1.375	#6	5/32"	0.250	1.125	1.250	0.046	0.931	0.313	6010035	3900	1950	0.400	1.438
PWN 10	PWN 10C	5/8	0.875	2.500	4.000	2.125	3.000	1.125	1.750	#8	3/16"	0.281	1.438	1.500	0.056	1.197	0.375	6010036	5880	2940	0.910	1.813
PWN 12	PWN 12C	3/4	0.937	2.750	4.500	2.375	3.500	1.250	1.875	#8	3/16"	0.313	1.563	1.625	0.056	1.330	0.438	6010037	7620	3810	1.060	1.938
PWN 16	PWN 16C	1	1.187	3.250	6.000	2.875	4.500	1.750	2.375	#10	7/32"	0.375	1.938	2.250	0.068	1.671	0.563	6010038	14100	7050	1.970	2.438
PWN 20	PWN 20C	1-1/4	1.500	4.000	7.500	3.500	5.500	2.000	3.000	#10	7/32"	0.438	2.500	2.625	0.068	2.122	0.625	6010039	20580	10290	3.725	3.125
PWN 24	PWN 24C	1-1/2	1.750	4.750	9.000	4.125	6.500	2.500	3.500	1/4"	9/32"	0.500	2.875	3.000	0.086	2.519	0.750	6010040	28200	14100	5.800	3.625
PWN 32	PWN 32C	2	2.125	6.000	10.000	5.250	8.250	3.250	4.500	3/8"	13/32"	0.625	3.625	4.000	0.103	3.182	1.000	6010041	50100	25050	12.125	4.688

- Notes:** (1) Standard, pre-assembled pillow blocks include self-aligning housing and precision bearing.  
 (2) All standard pillow blocks use standard FL series bearings.  
 (3) Twin pillowblocks, open, with no seal option: Use two standard open bearings, based on compensated or standard option.  
 (4) Twin pillowblocks, open, with double seal option: Use two double seal bearings.

INCH  
ISO METRIC  
JIS METRIC

# Simplicity® Flange Mounts

INCH

ISO METRIC

JIS METRIC

## Flange Mounts SFP

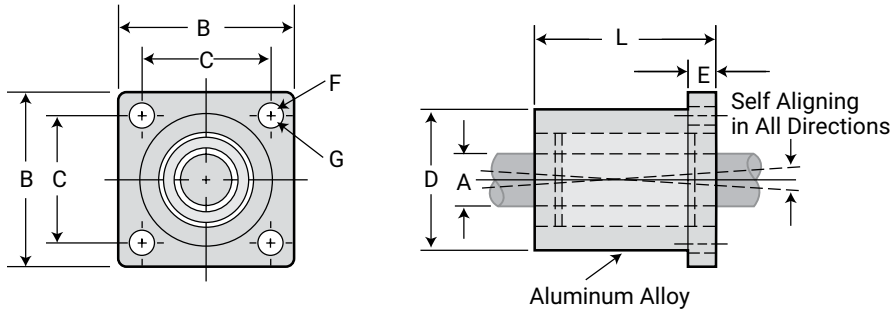

### DIMENSIONAL INFORMATION

Part No.		A Nominal Bearing Size	B Flange Square	C Hole Spacing	D Barrel Dia.	E Flange Length	F Bolt Size	G Hole Size	L Length Overall	MAX Static Load lb. Frelon®		Assembly Weight lb.
Precision	Compensated									Gold	J & W	
SFP 06	SFP 06 C	3/8"	1.25	1.00	0.875	0.188	#4	0.125	1.31	1020	510	0.070
SFP 08	SFP 08 C	1/2"	1.63	1.25	1.25	0.250	#8	0.187	1.687	1950	975	0.175
SFP 12	SFP 12 C	3/4"	2.38	1.75	1.75	0.375	#10	0.219	2.067	2940	1470	0.463
SFP 16	SFP 16 C	1"	2.75	2.125	2.25	0.500	1/4"	0.281	2.812	3810	1905	1.206
SFP 20	SFP 20 C	1 1/4"	3.88	3.00	2.62	0.625	3/8"	0.386	3.625	10830	5415	1.830

**Notes:** (1) All standard, pre-assembled SFP assemblies include a self-aligning housing and standard FL bearings - allowing the bearing to self-align.  
 (2) SFPB assemblies include a straight bore housing and standard FL bearings - allowing for a more rigid fit.

## Flange Mounts DFP

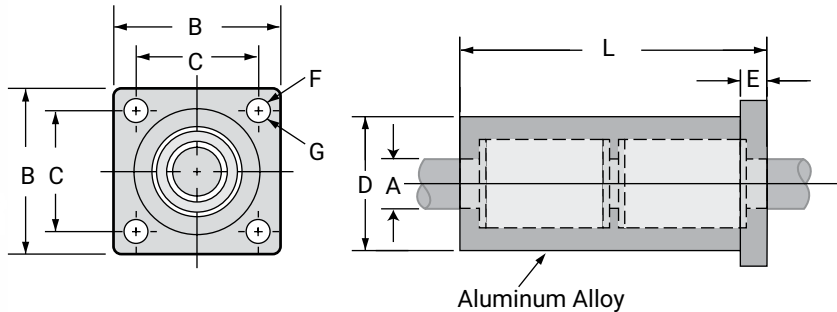

### DIMENSIONAL INFORMATION

Part No.		A Nominal Bearing Size	B Flange Square	C Hole Spacing	D Barrel Dia.	E Flange Length	F Bolt Size	G Hole Size	L Length Overall	MAX Static Load lb. Frelon®		Assembly Weight lb.
Precision	Compensated									Gold	J & W	
DFP 08	DFP 08 C	1/2"	1.63	1.25	1.25	0.250	#8	0.187	3.375	3900	1950	0.325
DFP 12	DFP 12 C	3/4"	2.38	1.75	1.75	0.375	#10	0.219	4.188	5880	2940	0.825
DFP 16	DFP 16 C	1"	2.75	2.125	2.25	0.500	1/4"	0.281	5.625	7620	3810	1.750

**Notes:** (1) All standard, pre-assembled DFP assemblies include a self-aligning housing and standard FL bearings - allowing the bearing to self-align.  
 (2) Straight bore DFPB assemblies include a straight bore housing and standard FL bearings - allowing for a more rigid fit.



**Only certified Simplicity 60 Plus Shafting provides maximum linear bearing performance.**

**Inch Series—page 52 Metric Series—page 90**

# Simplicity<sup>®</sup> Die Set Flange Mounts

## Flange Mounts SDS

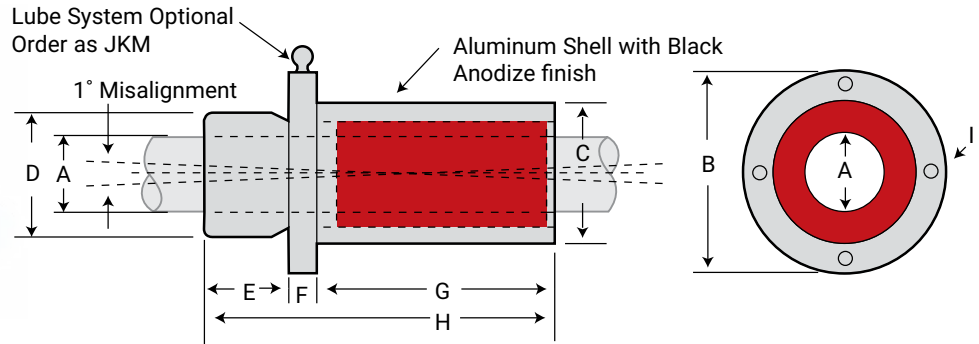

### DIMENSIONAL INFORMATION

Part No.		A Nominal Bearing Size	B Flange O.D.	C Barrel Dia.		D Pilot Dia.		E Pilot Length	F Flange Length	G Head Length	H Overall Length	I Mounting Holes 4 Places			MAX Static Load lb. Frelon <sup>®</sup>		Assembly Weight
Precision	Compensated			MIN.	MAX.	MIN.	MAX.					Bolt Size	Hole Size	Circle	Gold	J & W	lb.
SDSZ16	SDSZ16C	1"	3.00	2.098	2.100	1.4995	1.500	0.875	0.562	2.500	3.927	1/4"	0.281	2.550	7050	3525	0.941
SDSZ20	SDSZ20C	1-1/4"	3.50	2.598	2.600	1.7495	1.750	1.125	0.750	3.000	4.875	1/4"	0.281	3.050	10290	5145	1.852
SDSZ24	SDSZ24C	1-1/2"	4.25	2.998	3.000	1.9990	2.000	1.375	1.000	3.500	5.875	3/8"	0.406	3.650	14100	7050	2.983
SDSZ32	SDSZ32C	2"	5.00	3.748	3.750	2.4990	2.500	1.625	1.000	4.500	7.125	3/8"	0.406	4.400	25050	12525	5.032

Notes: (1) Shell material is aluminum.

(2) All standard, pre-assembled SDS assemblies include a straight bore housing and standard FLA bearings - allowing the bearing to self-align.

(3) SDSB assemblies include a straight bore housing and standard FL bearings - allowing for a more rigid fit.

## Flange Mounts DDS

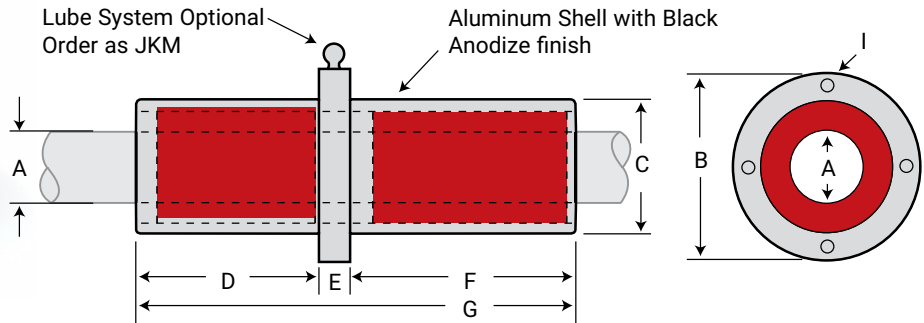

### DIMENSIONAL INFORMATION

Part No.		A Nominal Bearing Size	B Flange O.D.	C Barrel Dia.		D Length	E Flange Length	F Length	G Overall Length	I Mounting Holes 4 Places			MAX Static Load lb. Frelon <sup>®</sup>		Assembly Weight
Precision	Compensated			MIN.	MAX.					Bolt Size	Hole Size	Circle	Gold	J & W	lb.
DDSZ16	DDSZ16C	1"	3.00	2.098	2.100	2.5	0.562	3.500	6.563	1/4"	0.281	2.550	14100	7050	1.785
DDSZ20	DDSZ20C	1-1/4"	3.50	2.598	2.600	3	0.750	4.250	8.000	1/4"	0.281	3.050	20580	10290	3.203
DDSZ24	DDSZ24C	1-1/2"	4.25	2.998	3.000	3.5	1.000	5.000	9.500	3/8"	0.406	3.650	28200	14100	5.128
DDSZ32	DDSZ32C	2"	5.00	3.748	3.750	4.5	1.000	6.500	12.000	3/8"	0.406	4.400	50100	25050	9.015

Notes: (1) Shell material is aluminum.

(2) All standard, pre-assembled DDS assemblies include a straight bore housing and standard FLA bearings - allowing the bearing to self-align.

(3) All straight bore, pre-assembled DDSB assemblies include a straight bore housing and standard FL bearings - allowing for a more rigid fit.

INCH  
ISO METRIC  
JIS METRIC

# Simplicity® Sleeve Bearings

## Sleeve Bearings PS

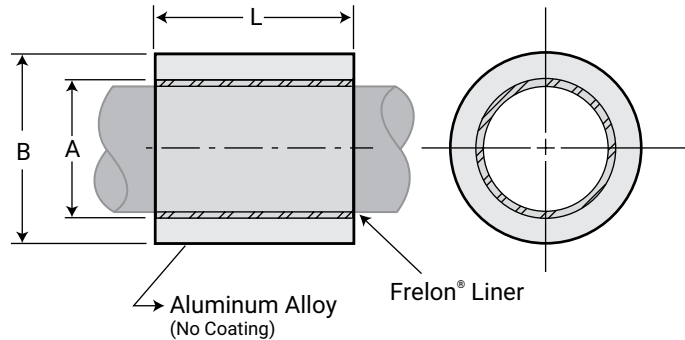
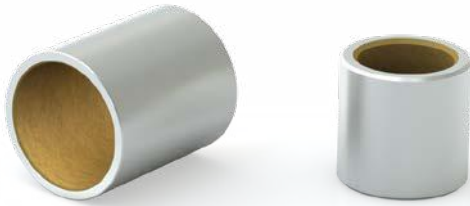

INCH

ISO METRIC

JIS METRIC

### DIMENSIONAL INFORMATION

Part No.	Nominal Bearing Size			A Bearing I.D.		B O.D.		L Length		MAX. Static Load lb. Frelon®		Bearing Weight OZ.	Recommended Housing Bore			
	I.D.	O.D.	Length	MIN	MAX	MIN	MAX	MIN	MA.	GOLD	J & W		Slip Fit & Epoxy		Press Fit	
													MIN	MAX	MIN	MAX
PS0305-02	3/16"	5/16"	1/4"	0.1890	0.1900	0.3135	0.3145	0.230	0.250	130	65	0.02	0.3145	0.3155	0.3125	0.3130
PS0305-04	3/16"	5/16"	1/2"	0.1890	0.1900	0.3135	0.3145	0.480	0.500	272	136	0.04	0.3145	0.3155	0.3125	0.3130
PS0406-02	1/4"	3/8"	1/4"	0.2515	0.2525	0.3760	0.3770	0.230	0.250	174	87	0.03	0.3770	0.3780	0.3750	0.3755
PS0406-03	1/4"	3/8"	3/8"	0.2515	0.2525	0.3760	0.3770	0.355	0.375	268	134	0.04	0.3770	0.3780	0.3750	0.3755
PS0406-04	1/4"	3/8"	1/2"	0.2515	0.2525	0.3760	0.3770	0.480	0.500	362	181	0.05	0.3770	0.3780	0.3750	0.3755
PS0610-04	3/8"	5/8"	1/2"	0.3765	0.3775	0.6260	0.6270	0.480	0.500	542	271	0.14	0.6270	0.6280	0.6250	0.6255
PS0610-06	3/8"	5/8"	3/4"	0.3765	0.3775	0.6260	0.6270	0.730	0.750	824	412	0.20	0.6270	0.6280	0.6250	0.6255
PS0710-06	7/16"	5/8"	3/4"	0.4390	0.4400	0.6260	0.6270	0.730	0.750	962	481	0.23	0.6270	0.6280	0.6250	0.6255
PS0812-04	1/2"	3/4"	1/2"	0.5015	0.5025	0.7510	0.7520	0.480	0.500	722	361	0.15	0.7520	0.7530	0.7500	0.7505
PS0812-06	1/2"	3/4"	3/4"	0.5015	0.5025	0.7510	0.7520	0.730	0.750	1098	549	0.25	0.7520	0.7530	0.7500	0.7505
PS0812-08	1/2"	3/4"	1"	0.5015	0.5025	0.7510	0.7520	0.980	1.000	1474	737	0.35	0.7520	0.7530	0.7500	0.7505
PS1014-06	5/8"	7/8"	3/4"	0.6265	0.6275	0.8760	0.8770	0.730	0.750	1372	686	0.30	0.8770	0.8780	0.8750	0.8755
PS1014-08	5/8"	7/8"	1"	0.6265	0.6275	0.8760	0.8770	0.980	1.000	1842	921	0.45	0.8770	0.8780	0.8750	0.8755
PS1216-08	3/4"	1"	1"	0.7515	0.7525	1.0010	1.0020	0.980	1.000	2210	1105	0.50	1.0020	1.0030	0.9995	1.0000
PS1216-10	3/4"	1"	1.25"	0.7515	0.7525	1.0010	1.0020	1.230	1.250	2777	1389	0.65	1.0020	1.0030	0.9995	1.0000
PS1620-12	1"	1-1/4"	1-1/2"	1.0015	1.0025	1.2510	1.2520	1.480	1.500	4446	2223	0.95	1.2520	1.2530	1.2490	1.2500
PS2024-16	1-1/4"	1-1/2"	2"	1.2515	1.2525	1.5010	1.5020	1.980	2.000	7434	3717	1.55	1.5020	1.5030	1.4990	1.5000
PS2428-16	1-1/2"	1-3/4"	2"	1.5015	1.5025	1.7510	1.7520	1.980	2.000	8918	4459	1.80	1.7520	1.7530	1.7490	1.7500
PS2832-24	1-3/4"	2"	3"	1.7515	1.7525	2.0010	2.0020	2.980	3.000	15658	7829	3.15	2.0020	2.0030	1.9990	2.0000
PS3236-24	2"	2-1/4"	3"	2.0015	2.0025	2.2510	2.2520	2.980	3.000	17894	8947	3.55	2.2520	2.2530	2.2490	2.2500
PS4044-24	2-1/2"	2-3/4"	3"	2.5015	2.5025	2.7510	2.7520	2.980	3.000	22364	11182	4.85	2.7520	2.7530	2.7490	2.7500
PS4852-28	3"	3-1/4"	3-1/2"	3.0015	3.0025	3.2510	3.2520	3.480	3.500	31336	15668	6.10	3.2520	3.2530	3.2485	3.2495

### ORDERING INFORMATION

PS	12	16	-	08
Type	I.D.	O.D.		Length
PS: Precision Sleeve Bearing	I.D. in 1/16" Increments	O.D. in 1/16" Increments		Length in 1/8" Increments

**Note:** Lengths not listed above must be specially quoted. Additional sizes are available within our online configurator.

Configure Online



**Only certified Simplicity 60 Plus Shafting provides maximum linear bearing performance.**

Inch Series—page 52 Metric Series—page 90



### INSTALLATION INSTRUCTIONS

1. Slip the bearing sleeve into the housing and epoxy into place with Loctite® or similar type bonding agent.

**CAUTION** Do NOT let any of the adhesive touch the bearing liner. It will harden and interfere with the running clearance.

2. Freeze the bearings at 0°F (-17.75°C) for 30-45 minutes. Using gloves, remove the bearings from the freezer and slip them into the housing. As they heat to room temperature, full contact between the bearing and housing will be achieved. The greatest advantage to this technique over traditional pressing is greater accuracy in alignment.

# Simplicity® Sleeve Bearings with Flange

## Sleeve Bearings with Flange PSF

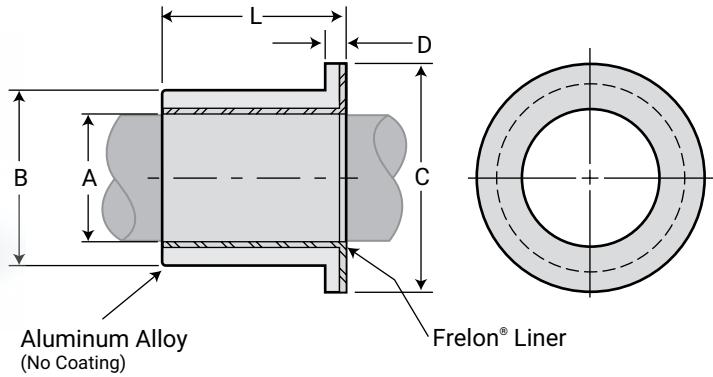

### DIMENSIONAL INFORMATION

Part No.	Nominal Bearing Size			A Bearing I.D.		B O.D.		C Flange O.D.	D Flange Width	L Length		MAX. Static Load lb. Frelon®		Bearing Weight OZ.	Recommended Housing Bore			
	I.D.	O.D.	Length	MIN	MAX	MIN	MAX			MIN	MAX	GOLD	J & W		Slip Fit & Epoxy		Press Fit	
PSF0305-02	3/16"	5/16"	1/4"	0.1890	0.1900	0.3135	0.3145	0.4370	0.0625	0.230	0.250	130	65	0.023	0.3145	0.3155	0.3125	0.3130
PSF0305-04	3/16"	5/16"	1/2"	0.1890	0.1900	0.3135	0.3145	0.4370	0.0625	0.480	0.500	272	136	0.044	0.3145	0.3155	0.3125	0.3130
PSF0406-02	1/4"	3/8"	1/4"	0.2515	0.2525	0.3760	0.3770	0.5000	0.0625	0.230	0.250	174	87	0.031	0.3770	0.3780	0.3750	0.3755
PSF0406-03	1/4"	3/8"	3/8"	0.2515	0.2525	0.3760	0.3770	0.5000	0.0625	0.355	0.375	268	134	0.044	0.3770	0.3780	0.3750	0.3755
PSF0406-04	1/4"	3/8"	1/2"	0.2515	0.2525	0.3760	0.3770	0.5000	0.0625	0.480	0.500	362	181	0.055	0.3770	0.3780	0.3750	0.3755
PSF0610-04	3/8"	5/8"	1/2"	0.3765	0.3775	0.6260	0.6270	0.8750	0.1250	0.480	0.500	542	271	0.20	0.6270	0.6280	0.6250	0.6255
PSF0610-06	3/8"	5/8"	3/4"	0.3765	0.3775	0.6260	0.6270	0.8750	0.1250	0.730	0.750	824	412	0.25	0.6270	0.6280	0.6250	0.6255
PSF0710-06	7/16"	5/8"	3/4"	0.4390	0.4400	0.6260	0.6270	0.9375	0.1250	0.730	0.750	962	481	0.20	0.6270	0.6280	0.6250	0.6255
PSF0812-04	1/2"	3/4"	1/2"	0.5015	0.5025	0.7510	0.7520	1.0000	0.1250	0.480	0.500	722	361	0.25	0.7520	0.7530	0.7500	0.7505
PSF0812-06	1/2"	3/4"	3/4"	0.5015	0.5025	0.7510	0.7520	1.0000	0.1250	0.730	0.750	1098	549	0.30	0.7520	0.7530	0.7500	0.7505
PSF0812-08	1/2"	3/4"	1"	0.5015	0.5025	0.7510	0.7520	1.0000	0.1250	0.980	1.000	1474	737	0.40	0.7520	0.7530	0.7500	0.7505
PSF1014-06	5/8"	7/8"	3/4"	0.6265	0.6275	0.8760	0.8770	1.0000	0.1250	0.730	0.750	1372	686	0.35	0.8770	0.8780	0.8750	0.8755
PSF1014-08	5/8"	7/8"	1"	0.6265	0.6275	0.8760	0.8770	1.0000	0.1250	0.980	1.000	1842	921	0.45	0.8770	0.8780	0.8750	0.8755
PSF1216-08	3/4"	1"	1"	0.7515	0.7525	1.0010	1.0020	1.2500	0.1250	0.980	1.000	2210	1105	0.55	1.0020	1.0030	0.9995	1.0000
PSF1620-12	1"	1-1/4"	1-1/2"	1.0015	1.0025	1.2510	1.2520	1.5000	0.1250	1.480	1.500	4446	2223	1.05	1.2520	1.2530	1.2490	1.2500
PSF2024-16	1-1/4"	1-1/2"	2"	1.2515	1.2525	1.5010	1.5020	1.7500	0.1250	1.980	2.000	7434	3717	1.80	1.5020	1.5030	1.4990	1.5000
PSF2428-16	1-1/2"	1-3/4"	2"	1.5015	1.5025	1.7510	1.7520	2.0000	0.1250	1.980	2.000	8918	4459	2.16	1.7520	1.7530	1.7490	1.7500
PSF2832-24	1-3/4"	2"	3"	1.7515	1.7525	2.0010	2.0020	2.2500	0.1250	2.980	3.000	15658	7829	3.30	2.0020	2.0030	1.9990	2.0000
PSF3236-24	2"	2-1/4"	3"	2.0015	2.0025	2.2510	2.2520	2.5000	0.1250	2.980	3.000	17894	8947	3.75	2.2520	2.2530	2.2490	2.2500
PSF4044-24	2-1/2"	2-3/4"	3"	2.5015	2.5025	2.7510	2.7520	3.0000	0.1250	2.980	3.000	22364	11182	4.60	2.7520	2.7530	2.7490	2.7500
PSF4852-28	3"	3-1/4"	3-1/2"	3.0015	3.0025	3.2510	3.2520	3.5000	0.1250	3.480	3.500	31336	15668	6.30	3.2520	3.2530	3.2485	3.2495

### ORDERING INFORMATION

PSF	12	16	-	08
Type	I.D.	O.D.		Length
PSF: Precision Sleeve Bearing with Flange	I.D. in 1/16" Increments	O.D. in 1/16" Increments		Length in 1/8" Increments

Note: Lengths not listed above must be specially quoted.  
Additional sizes are available within our online configurator.

Configure  
Online



Only certified Simplicity 60 Plus  
Shafting provides maximum linear  
bearing performance.

Inch Series—page 52 Metric Series—page 90



### INSTALLATION INSTRUCTIONS

- Slip the bearing sleeve into the housing and epoxy into place with Loctite® or similar type bonding agent.



Do NOT let any of the adhesive touch the bearing liner. It will harden and interfere with the running clearance.

- Freeze the bearings at 0°F (-17.75°C) for 30-45 minutes. Using gloves, remove the bearings from the freezer and slip them into the housing. As they heat to room temperature, full contact between the bearing and housing will be achieved. The greatest advantage to this technique over traditional pressing is greater accuracy in alignment.

# Simplicity® Die Set Bushings

## Die Set Bushings PAC

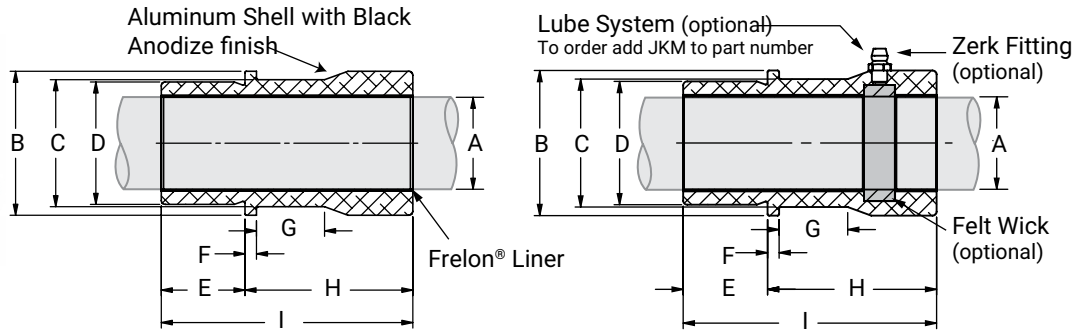

### DIMENSIONAL INFORMATION

P = Precision C = Compensated	Part No.	Nominal Size in.	A Bearing I.D.		B Flange & Barrel O.D.		C Clamp Dia.	D Pilot O.D.		E Pilot Length	F Flange Length	G Recess Length	H Head Length	I Overall Length	Effective Surface Area sq. in.	MAX Static Load lb.		Bearing Weight lb.
			MIN	MAX	MIN	MAX	MIN	MIN	MAX	Pilot Length	Flange Length	Recess Length	Head Length	Overall Length		Frelon® GOLD	J & W	
P	PACZ750	3/4	0.750	0.7510	1.285	1.300	1.012	1.1245	1.1250	0.812	0.188	0.712	2.000	2.812	2.209	6626	3313	0.625
C	PACZ750C		0.753	0.7540														
P	PACZ100	1	1.000	1.0010	1.723	1.738	1.450	1.4995	1.5000	0.875	0.188	0.812	2.250	3.125	3.272	9817	4909	1.000
C	PACZ100C		1.003	1.0040														
P	PACZ125	1-1/4	1.250	1.2510	2.097	2.112	1.825	1.7495	1.7500	1.125	0.188	0.812	2.375	3.500	4.581	13744	6872	1.500
C	PACZ125C		1.254	1.2550														
P	PACZ150	1-1/2	1.500	1.5012	2.346	2.361	2.075	1.9995	2.0000	1.375	0.188	1.112	2.750	4.125	6.480	19439	9719	2.000
C	PACZ150C		1.504	1.5050														
P	PACZ200	2	2.000	2.0014	3.095	3.110	2.825	2.4995	2.5000	1.625	0.188	1.112	3.000	4.625	9.687	29060	14530	4.188
C	PACZ200C		2.005	2.0064														
P	PACZ250	2-1/2	2.500	2.5016	3.595	3.610	3.325	2.9995	3.0000	1.875	0.188	1.112	3.500	5.375	14.072	42215	21108	6.000
C	PACZ250C		2.505	2.5065														
P	PACZ300	3	3.000	3.0020	4.345	4.360	4.075	3.6245	3.6250	1.875	0.188	1.112	4.000	5.875	18.457	55371	27685	10.000
C	PACZ300C		3.006	3.0080														

- Notes:** (1) Formula used for effective surface area is  $(\pi * ID * L)/3$ .  
 (2) Shell material is aluminum.  
 (3) For lubrication system add JKM, example: PACZ750JKM.  
 (4) Max static load is effective surface area times max load for FrelonGOLD®.  
 (5) - 3000 psi is the rating for FrelonGOLD®; 1500 psi is the rating for Frelon J & W.

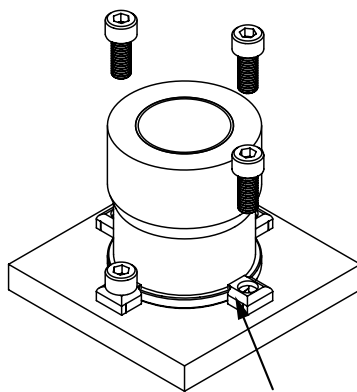

4 PAC clamps are shipped with each die set.  
 Extra clamps can be ordered using part # PACCLAMP.

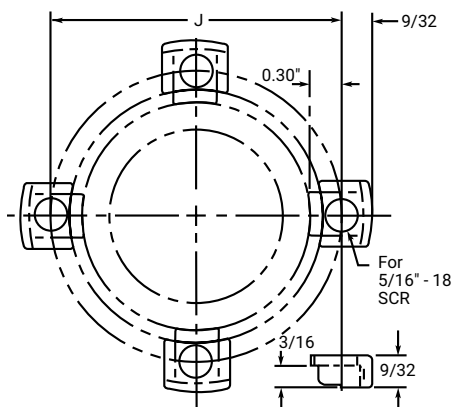

Dimension for calculating bolt circle:  $J = C + 0.60"$

# Plain Bearings Accessories

## Retaining Rings (External)

FL Series	Part No.
FL03	6010001
FL04	6010002
FL06	6010003
FL08	6010004
FL10	6010005
FL12	6010006
FL16	6010007
FL20	6010008
FL24	6010009
FL32	6010010
FL40	6010011
FL48	6010012
FL64	6010013
FM Series	Part No.
FM05	6010014
FM08	6010015
FM10	6010016
FM12	6010017
FM16	6010018
FM20	6010019
FM25	6010020
FM30	6010021
FM40	6010022
FM50	6010023
FM60	6010024
FM80	6010025

## Seals

FL Series	Part No.		
	Polymod	Viton	Urethane
FL08	6030001	6030009	6030017
FL10	6030002	6030010	6030018
FL12	6030003	6030011	6030019
FL16	6030004	6030012	6030020
FL20	6030005	6030013	6030021
FL24	6030006	6030014	6030022
FL32	6030007	6030015	6030023
FL40	6030008	6030016	6030024
FL48	N/A	N/A	6030025
FL64	N/A	N/A	6030026
FM/FJ Series	Part No.		
FM20/FJ20	N/A	N/A	6030027
FM25/FJ25	N/A	N/A	6030028
FM30/FJ30	N/A	N/A	6030029
FJ35	N/A	N/A	6030030
FJ38	N/A	N/A	6030030
FM40/FJ40	N/A	N/A	6030031
FM50/FJ50	N/A	N/A	6030032
FM60/FJ60	N/A	N/A	6030033
FM80/FJ80	N/A	N/A	6030034
FJ100	N/A	N/A	6030052
FJ120	N/A	N/A	6030053

## O-Rings

FL Series	Part No.	
	Nitrile buna 70	Viton
FL04	6000001	N/A
FL06	6000002	6000037
FL08	6000003	6000038
FL10	6000004	6000039
FL12	6000005	6000040
FL16	6000006	6000041
FL20	6000007	6000042
FL24	6000008	6000043
FL32	6000009	6000044
FL40	6000010	6000045
FL48	6000011	6000046
FL64	6000012	6000047
FM/FJ Series	Part No.	
FM08	6000014	N/A
FM10	6000015	N/A
FM12	6000016	N/A
FM16	6000017	N/A
FM20	6000018	N/A
FM25	6000019	N/A
FM30	6000020	N/A
FM40	6000021	N/A
FM50	6000022	N/A
FM60	6000023	N/A
FM80	6000024	N/A

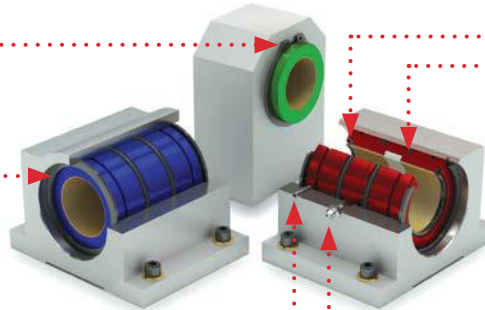

## Retaining Rings (Internal)

*Inch Open	Part No.		*Metric Open	Part No.	
	Steel	Stainless Steel		Steel	*Stainless Steel
PN08	6010035	6010064	PMN12	6010044	N/A
PN10	6010036	6010066	PMN16	6010045	6010107
PN12	6010037	6010068	PMN20	6010046	N/A
PN16	6010038	6010070	PMN25	6010047	N/A
PN20	6010039	6010072	PMN30	6010048	6010083
PN24	6010040	6010074	PMN40	6010049	N/A
PN32	6010041	6010076	PMN50	6010050	N/A
Closed	Part No.		Closed	Part No.	
P04	6010026	6010052	PM08	6010042	N/A
P06	6010027	6010053	PM10	6010043	N/A
P08	6010028	6010054	PM12	6010044	N/A
P10	6010029	6010055	PM16	6010045	6010107
P12	6010030	6010056	PM20	6010046	N/A
P16	6010031	6010057	PM25	6010047	N/A
P20	6010032	6010058	PM30	6010048	6010083
P24	6010033	6010059	PM40	6010049	N/A
P32	6010034	6010060	PM50	6010050	N/A

## Zerk Fittings

Inch	Part No.
1/4-28" Steel	6050002
1/4-28" Stainless	6050003
Metric	Part No.
M8 x 1.0 Steel	6050001

## Roll Pin

Inch Open	Part No.
PN08	6060001
PN10	6060002
PN12	6060003
PN16	6060004
PN20	6060005
PN24	6060006
PN32	6060007
Metric Open	Part No.
PMN12	6060010
PMN16	6060009
PMN20	6060009
PMN25	6060010
PMN30	6060010
PMN40	6060012
PMN50	6060012

\* Purchased retaining ring components (an accessory item listed above) are the custom's responsibility to trim/cut tabbed ends. When purchased as part of a PBC Linear complete pre-assembled open pillow block assembly, tabbed ends will be trimmed/cut at factory prior to shipment.













# Ball Bearings Selection Guide

**I** Inch Series

**M** ISO Metric Series

**J** JIS Metric Series

PERFORMANCE

Sizes	Product Type & Description	Available In:			Found on Page		
		Open	Closed	Wide	I	M	J
<b>I</b> <b>M</b> <b>J</b>	<p><b>Precision</b></p> <p>Materials: steel with polymer retainer</p>  <p>Each ball bearing consists of an outer cylinder, ball retainer, balls, and two double seals.</p>	•	•		<b>34</b>	<b>78</b>	<b>100</b>
<b>I</b> <b>M</b>	<p><b>Pillow Blocks</b></p> <p>Materials: aluminum housing with clear anodized coating, inner steel, and polymer bearing</p>  <p>Size interchangeable, industry standard pillow block housing.</p>	•	••		<b>38</b>	<b>71</b>	
<b>I</b>	<p><b>Pillow Blocks – Double Wide</b></p> <p>Materials: aluminum housing with clear anodized coating, inner steel, and polymer bearing</p>  <p>Extended length, size interchangeable, industry standard pillow block housing.</p>	•	•	•	<b>39</b>		
<b>I</b>	<p><b>Precision Plus Self-Aligning</b></p> <p>Materials: steel and polymer</p>  <p>Interchangeable with industry standard super-type ball bearings. Inserts provide 1/2° self-alignment in all directions when used in a straight bore pillow block or housing.</p>	•	•		<b>35</b>	<b>78</b>	
<b>M</b>	<p><b>Thin Wall</b></p> <p>Materials: steel with polymer retainer</p>  <p>A thin wall bushing in European metric sizes.</p>		•			<b>88</b>	
<b>I</b> <b>M</b> <b>J</b>	<p><b>Double Wide</b></p> <p>Materials: steel with polymer retainer</p>  <p>Extended length ball bearings consisting of steel outer cylinder, ball retainer, balls, and two double seals.</p>		•	•	<b>40</b>	<b>80</b>	<b>101</b>
<b>M</b> <b>J</b>	<p><b>Flange Mount</b></p> <p>Materials: steel with polymer retainer</p>  <p>Standard ball bearing with either a square or round flange.</p>		•			<b>82</b>	<b>102</b>
<b>M</b> <b>J</b>	<p><b>Flange Mount – Double Wide</b></p> <p>Materials: steel with polymer retainer</p>  <p>Extended length standard ball bearing with either a square or round flange.</p>		•	•		<b>84</b>	<b>104</b>
<b>M</b> <b>J</b>	<p><b>Flange Mount – Center</b></p> <p>Materials: aluminum alloy housing with clear anodized coating, inner bearing steel, and polymer retainer</p>  <p>Extended length standard ball bearing with a center located square or round flange.</p>		•			<b>86</b>	<b>106</b>
<b>I</b>	<p><b>Linear Slide Assemblies</b></p> <p>Materials: alloy steel, 440 stainless steel, or chrome plated shafts, aluminum support rails, standard self-aligning pillowblocks</p> <p><b>Ball bearing slide assemblies.</b></p> <p>Standard components include: mounting plate, pillow block assemblies, steel shafts, and support rails. Options include shaft materials, lead screws, ball screws, hand cranks, and motors.</p> 				<b>109</b>		
<b>I</b> <b>M</b>	<p><b>Round Shafting</b></p> <p>Materials: hardened steel, 440 stainless steel</p>  <p>Cut to length, random lengths, machined, pre-drilled, or tapped.</p> <p>Shaft assemblies and support rails also available.</p>				<b>52</b>	<b>89</b>	

# Ball Bearings Overview

## Product Overview

### High Precision and Rigidity

The Simplicity® ball bearing is produced from a solid steel outer cylinder and incorporates an industrial strength polymer retainer.

### Ease of Assembly

The standard type of linear ball bearing can be loaded from any direction. Precision control is possible using only the shaft supporter, and the mounting surface can be machined easily.

### Ease of Replacement

Linear ball bearings of each type are completely interchangeable because of their standardized dimensions and strict precision control. Replacement because of wear or damage is therefore easy and accurate.

### Materials

Ball bearings consist of an outer cylinder, ball retainer, balls, double seals, and two end rings. The ball retainer which holds the balls in the recirculating tracks is held inside the outer cylinder by end rings.

- Parts are assembled to optimize their required functions
- The outer shell is heat treated to ensure long life
- The ball retainer is molded from a durable polymer to ensure smooth and quiet motion
- Double seals are standard for all ball bearings. Seals can be easily removed for applications requiring one or no seals.

## Variety of Types

PBC Linear offers a full line of ball bearings that include:

- Inch, ISO Metric, and JIS Metric sizes
- Self-aligning super ball bearings in Inch sizes
- Double wide in Inch, ISO Metric, and JIS Metric sizes
- Square and round flange in ISO Metric and JIS Metric sizes
- Double wide square and round flange in ISO Metric and JIS Metric sizes
- Double wide with center flange location in ISO Metric and JIS Metric sizes
- Pillow blocks, open and closed, in Inch and ISO Metric
- Double wide pillow blocks in Inch sizes

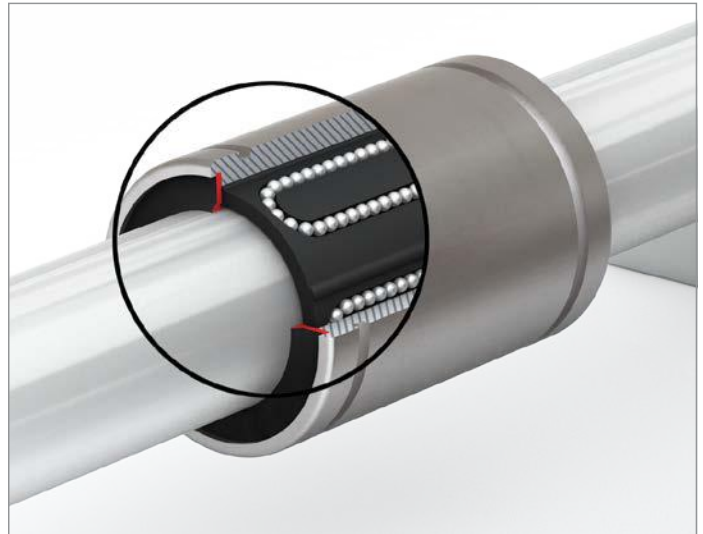

**Only certified Simplicity 60 Plus Shafting provides maximum linear bearing performance.**

**Inch Series—page 52 Metric Series—page 90**

# Ball Bearings Overview

Simplicity® linear ball bearings are available in a variety of configurations designed to meet a range of application needs.

## Bearings – IP, EP, and JP Series (Inch, ISO, and JIS Metric)

- Solid steel outer shell

## Pillow Blocks – IPP and EPP (Inch and ISO Metric)

- Aluminum housing with bearing insert
- Industrial strength polymer ball retainer
- End rings with integrated seals standard
- Used in standard PBC Linear pillow blocks that supply 1/2° self-alignment in all directions
- Excellent rigidity while providing smooth, quiet operation

## IPS and EPS Series

- Outer shell is of high strength polymer
- Ball bearing raceway inserts are hardened steel
- Inserts allow smooth ball rotation while maintaining even preload with the shaft or inner race
- Inserts provide 1/2° self-alignment in all directions when used in a straight bore pillow block or housing
- Provide increased load capacity and life in a lightweight design

## Flanged Bearings – EP, and JP Series (ISO, and JIS Metric)

- Solid steel outer shell
- Industrial strength polymer ball retainer
- End rings with integrated seals standard
- Excellent rigidity while providing smooth, quiet operation

IP, EP, JP Series

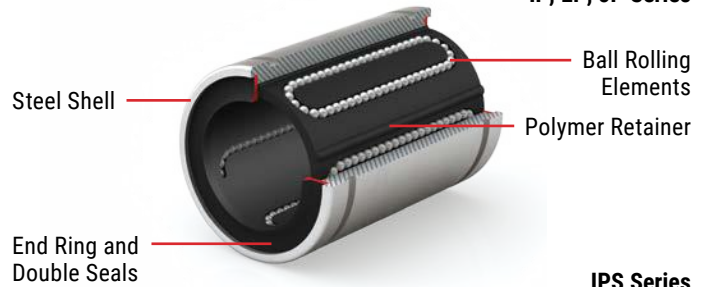

IPS Series

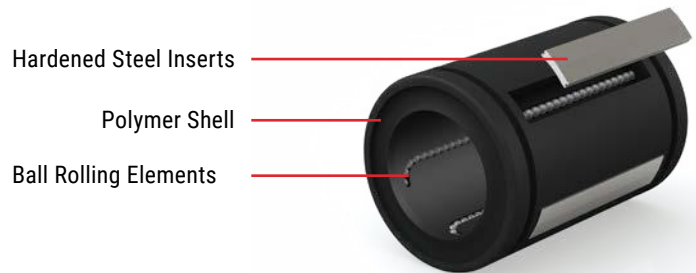

IP, EP, JP Flanged Series

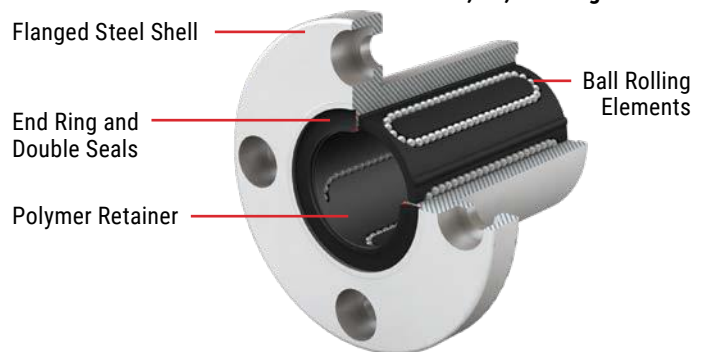

PERFORMANCE

## Self-Aligning Pillow Blocks

Pillow blocks combine linear ball bearings with a PBC Linear self-aligning pillow block to compensate for misalignment or shaft deflection in the application

- Straight OD bearings are used in standard PBC Linear pillow blocks that supply 1/2° self-alignment in all directions
- Straight bore pillow blocks are also available for applications which demand more rigidity
- PBC Linear bearings are size interchangeable with industry standard ball bearings and with Simplicity plain bearings

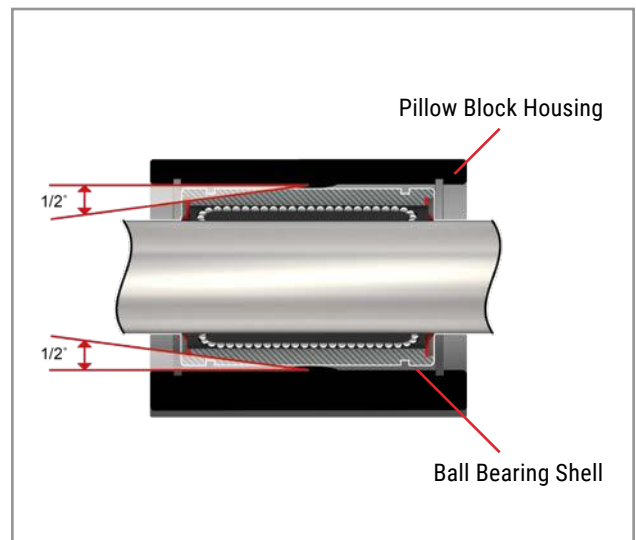

# Ordering Information Linear Ball Bearings

## Ball Bearings



Configure  
Online

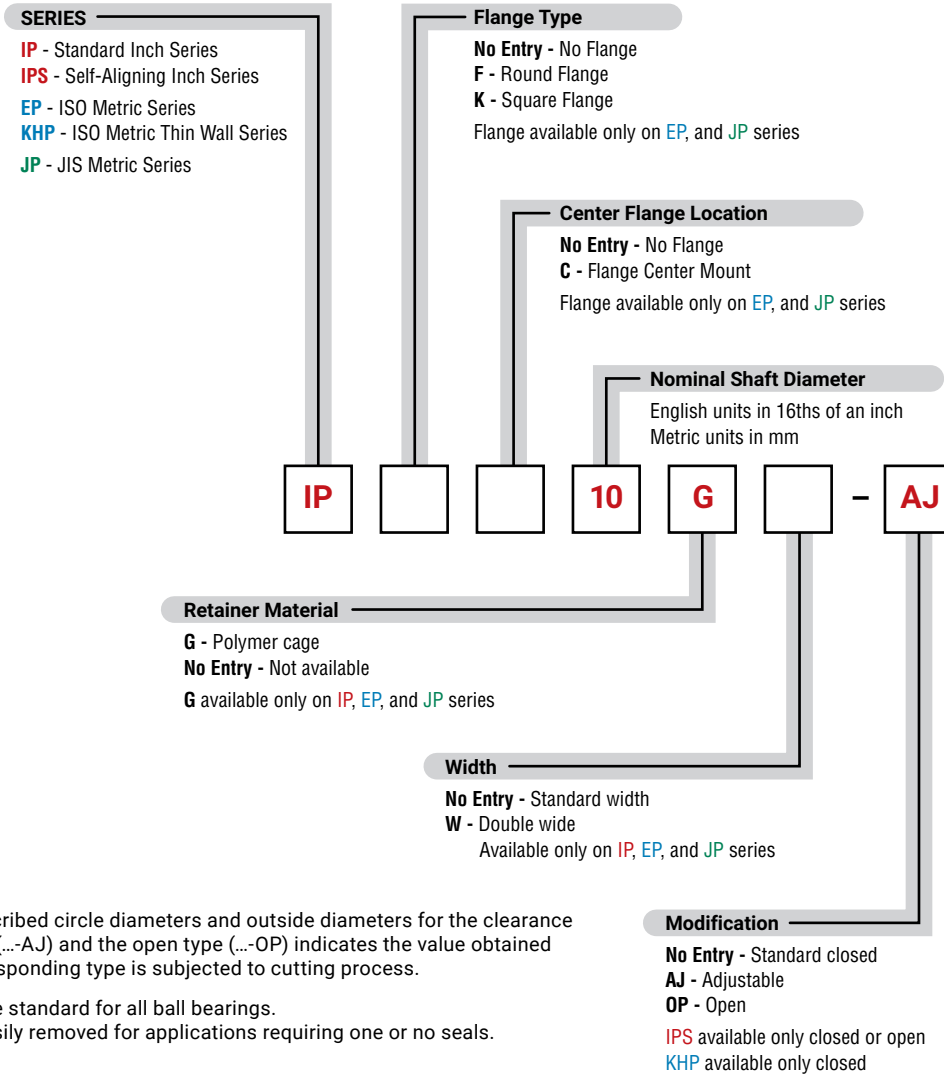

**Note:** Precision of inscribed circle diameters and outside diameters for the clearance adjustable type (...AJ) and the open type (...OP) indicates the value obtained before the corresponding type is subjected to cutting process.

Double Seals are standard for all ball bearings.  
Seals can be easily removed for applications requiring one or no seals.

## Ball Bearing Pillow Blocks

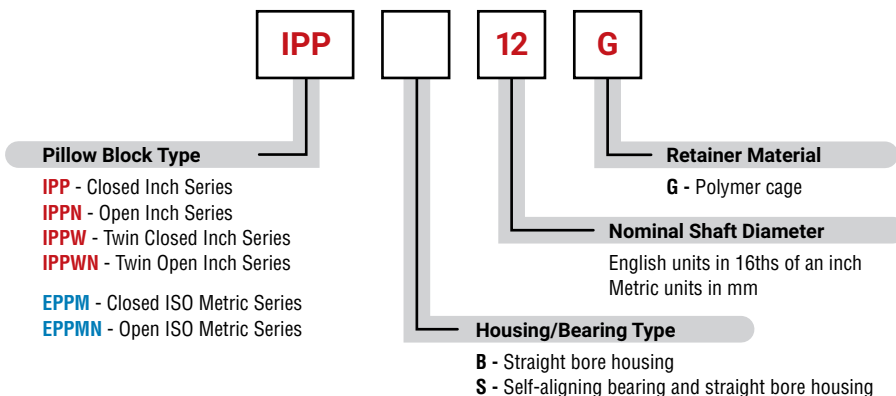

ORDERING

# Linear Ball Bearings Precision

## Ball Bearings IP

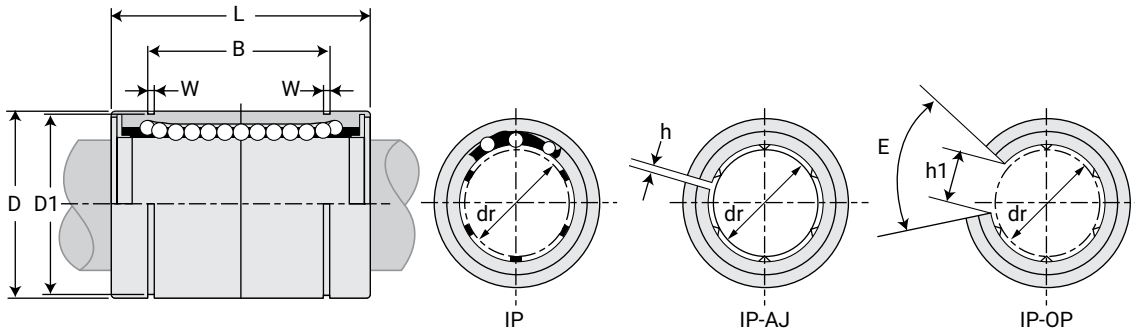

IP – Standard Closed

IPxx-AJ – Adjustable

IPxx-OP – Standard Open



### DIMENSIONAL INFORMATION

(Standard Steel Finish)

Part No.			Nominal Diameter			Ball Circuit	Weight G	Major Dimensions & Tolerances					
Standard Closed	Adjustable	Standard Open	Size in.	Dr in.	Tolerance in.			D in.	Tolerance in.	L in.	Tolerance in.	B in.	Tolerance in.
IP04G	-	-	1/4	0.2500	0/-0.0005	4	8	0.5000	0/-0.00045	0.7500	0/-0.008	0.5110	0/-0.008
IP06G	-	-	3/8	0.3750	0/-0.0005	4	15	0.6250	0/-0.00050	0.8750	0/-0.008	0.6358	0/-0.008
IP08G	IP8G-AJ	IP8G-OP	1/2	0.5000	0/-0.0005	4	42	0.8750	0/-0.00050	1.2500	0/-0.008	0.9625	0/-0.008
IP10G	IP10G-AJ	IP10G-OP	5/8	0.6250	0/-0.0005	5	85	1.1250	0/-0.00050	1.5000	0/-0.008	1.1039	0/-0.008
IP12G	IP12G-AJ	IP12G-OP	3/4	0.7500	0/-0.0005	5	104	1.2500	0/-0.00065	1.6250	0/-0.008	1.1657	0/-0.008
IP16G	IP16G-AJ	IP16G-OP	1	1.0000	0/-0.0005	6	220	1.5625	0/-0.00065	2.2500	0/-0.012	1.7547	0/-0.012
IP20G	IP20G-AJ	IP20G-OP	1-1/4	1.2500	0/-0.0006	6	465	2.0000	0/-0.00075	2.6250	0/-0.012	2.0047	0/-0.012
IP24G	IP24G-AJ	IP24G-OP	1-1/2	1.5000	0/-0.0006	6	720	2.3750	0/-0.00075	3.0000	0/-0.012	2.4118	0/-0.012
IP32G	IP32G-AJ	IP32G-OP	2	2.0000	0/-0.0008	6	1310	3.0000	0/-0.00090	4.0000	0/-0.012	3.1917	0/-0.012

Part No.			Nominal Diameter			Major Dimensions & Tolerances							Load Ratings	
Standard Closed	Adjustable	Standard Open	Size in.	dr in.	Tolerance in.	W in.	D1 in.	H in.	h1 in.	E Slot Angle	Max Eccentricity in.	Max Radial Clearance in.	Dynamic C lb.	Static Co lb.
IP04G	-	-	1/4	0.2500	0/-0.0005	0.0390	0.4687	-	-	-	0.0004	-0.0001	46	59
IP06G	-	-	3/8	0.3750	0/-0.0005	0.0390	0.5880	-	-	-	0.0004	-0.0001	50	70
IP08G	IP8G-AJ	IP8G-OP	1/2	0.5000	0/-0.0005	0.0459	0.8209	0.06	0.3400	80°	0.0004	-0.0001	114	176
IP10G	IP10G-AJ	IP10G-OP	5/8	0.6250	0/-0.0005	0.0559	1.0590	0.06	0.3750	80°	0.0004	-0.0001	174	265
IP12G	IP12G-AJ	IP12G-OP	3/4	0.7500	0/-0.0005	0.0559	1.1760	0.06	0.4375	60°	0.0005	-0.0002	193	307
IP16G	IP16G-AJ	IP16G-OP	1	1.0000	0/-0.0005	0.0679	1.4687	0.06	0.5625	50°	0.0005	-0.0002	220	352
IP20G	IP20G-AJ	IP20G-OP	1-1/4	1.2500	0/-0.0006	0.0679	1.8859	0.10	0.6250	50°	0.0007	-0.0003	352	615
IP24G	IP24G-AJ	IP24G-OP	1-1/2	1.5000	0/-0.0006	0.0859	2.2389	0.12	0.7500	50°	0.0007	-0.0003	490	903
IP32G	IP32G-AJ	IP32G-OP	2	2.0000	0/-0.0008	0.1029	2.8379	0.12	1.000	50°	0.0009	-0.0005	858	1784



Only certified Simplicity 60 Plus Shafting provides maximum linear bearing performance.

Inch Series—page 52 Metric Series—page 90

# Linear Ball Bearings Precision Plus Self Aligning

## Precision Plus Self Aligning Ball bearings IPS & IPSXX-OP

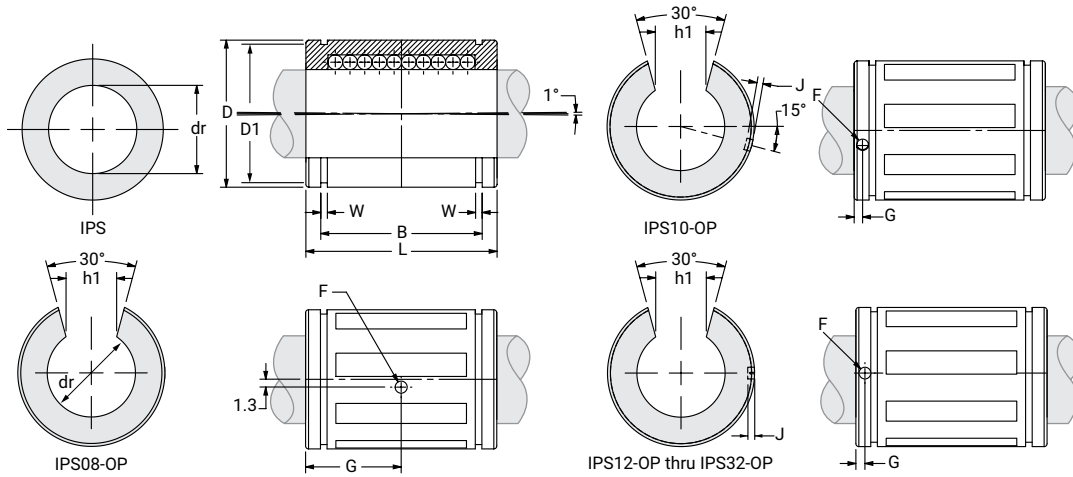

IPS – Self Aligning Closed

IPSxx-OP – Self Aligning Open



### DIMENSIONAL INFORMATION

Part No. Self Aligning Closed	Nominal Diameter			Ball Circuit	Weight lb.	Major Dimensions & Tolerances							Load Ratings	
	Size in.	dr in.	Tolerance in.			D in.	L in.	Tolerance in.	B in.	Tolerance in.	W in.	D1 in.	Dynamic C lb.	Static Co lb.
IPS04	1/4	0.2500	0/-0.0005	4	0.009	0.5000	0.7500	0/-0.015	0.515	0/-0.015	0.0390	0.4687	57	49
IPS06	3/8	0.3750	0/-0.0005	4	0.014	0.6250	0.8750	0/-0.015	0.703	0/-0.015	0.0390	0.5880	78	66
IPS08	1/2	0.5000	0/-0.0005	4	0.043	0.8750	1.2500	0/-0.020	1.032	0/-0.020	0.0459	0.8209	190	190
IPS10	5/8	0.6250	0/-0.0005	5	0.103	1.1250	1.5000	0/-0.020	1.112	0/-0.020	0.0559	1.0590	290	340
IPS12	3/4	0.7500	0/-0.0005	6	0.123	1.2500	1.6250	0/-0.020	1.272	0/-0.020	0.0559	1.1760	470	430
IPS16	1	1.0000	0/-0.0005	6	0.265	1.5625	2.2500	0/-0.020	1.886	0/-0.020	0.0679	1.4687	820	780
IPS20	1-1/4	1.2500	0/-0.0006	6	0.485	2.0000	2.6250	0/-0.025	2.011	0/-0.025	0.0679	1.8859	1230	1270
IPS24	1-1/2	1.5000	0/-0.0006	6	0.750	2.3750	3.0000	0/-0.030	2.422	0/-0.030	0.0859	2.2389	1479	1540
IPS32	2	2.0000	0/-0.0008	6	1.411	3.0000	4.0000	0/-0.040	3.206	0/-0.040	0.1029	2.8379	2230	2580

### DIMENSIONAL INFORMATION

Part No. Self Aligning Open	Nominal Diameter			Ball Circuit	Weight lb.	Major Dimensions & Tolerances											Load Ratings	
	Size in.	dr in.	Tolerance in.			D in.	L in.	Tolerance in.	B in.	Tolerance in.	W in.	D1 in.	h1 in.	F in.	G in.	J in.	Dynamic C lb.	Static Co lb.
IPS08-OP	1/2	0.5000	0/-0.0005	3	0.033	0.8750	1.2500	0/-0.020	1.032	0/-0.020	0.0459	0.8209	0.313	0.136	0.6250	through	210	159
IPS10-OP	5/8	0.6250	0/-0.0005	4	0.083	1.1250	1.5000	0/-0.020	1.112	0/-0.020	0.0559	1.0590	0.375	0.105	0.1250	0.039	320	340
IPS12-OP	3/4	0.7500	0/-0.0005	5	0.102	1.2500	1.6250	0/-0.020	1.272	0/-0.020	0.0559	1.1760	0.438	0.136	0.1250	0.059	470	430
IPS16-OP	1	1.0000	0/-0.0005	5	0.220	1.5625	2.2500	0/-0.020	1.886	0/-0.020	0.0679	1.4687	0.563	0.136	0.1250	0.047	830	780
IPS20-OP	1-1/4	1.2500	0/-0.0006	5	0.419	2.0000	2.6250	0/-0.025	2.011	0/-0.025	0.0679	1.8859	0.625	0.201	0.1875	0.090	1230	1270
IPS24-OP	1-1/2	1.5000	0/-0.0006	5	0.639	2.3750	3.0000	0/-0.030	2.422	0/-0.030	0.0859	2.2389	0.750	0.201	0.1875	0.090	1479	1540
IPS32-OP	2	2.0000	0/-0.0008	5	1.168	3.0000	4.0000	0/-0.040	3.206	0/-0.040	0.1029	2.8379	1.000	0.265	0.3125	through	2250	2580

# Linear Ball Bearings Precision Plus Pillow Blocks with Lubrication Ports

INCH

ISO METRIC

JIS METRIC

## Closed Pillow Blocks IPPS

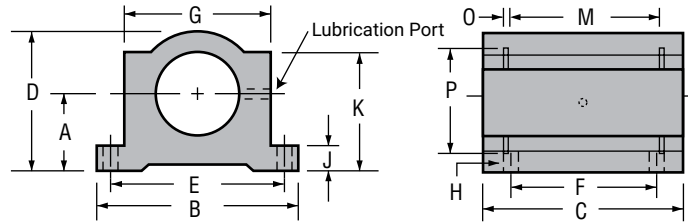

### DIMENSIONAL INFORMATION

Part No.	Nom. Brg. I.D. in.	A Centerline +/- 0.001	B Width	C Length	D Height	E +/- 0.010	F +/- 0.010	G		J Flange Thick	K	M GRV. Space	O GRV. Width	P GRV. Dia.	Assem. WT. lb	Load Ratings	
								Body Width	H Bolt Hole							Dynamic C lb	Static Co lb
IPPS08G	1/2	0.687	2.000	1.69	1.250	1.688	1.000	1.375	#6 5/32"	0.250	1.125	1.250	0.046	0.931	0.200	230	159
IPPS10G	5/8	0.875	2.500	1.94	1.625	2.125	1.125	1.750	#8 3/16"	0.281	1.438	1.500	0.056	1.197	0.500	400	264
IPPS12G	3/4	0.937	2.750	2.06	1.750	2.375	1.250	1.875	#8 3/16"	0.313	1.563	1.625	0.056	1.330	0.600	470	372
IPPS16G	1	1.187	3.250	2.81	2.188	2.875	1.750	2.375	#10 7/32"	0.375	1.938	2.250	0.068	1.671	1.200	850	667
IPPS20G	1-1/4	1.500	4.000	3.63	2.813	3.500	2.000	3.000	#10 7/32"	0.438	2.500	2.625	0.068	2.122	2.500	1230	992
IPPS24G	1-1/2	1.750	4.750	4.00	3.250	4.125	2.500	3.500	1/4" 9/32"	0.500	2.875	3.000	0.086	2.519	3.800	1480	1258
IPPS32G	2	2.125	6.000	5.00	4.063	5.250	3.250	4.500	3/8" 13/32"	0.625	3.625	4.000	0.103	3.182		2430	2165

Notes: (1) All IPPS series pillow blocks use IPS series self-aligning bearings.  
(2) Includes grease zerk fittings for relubrication.

## Open Pillow Blocks IPPSN

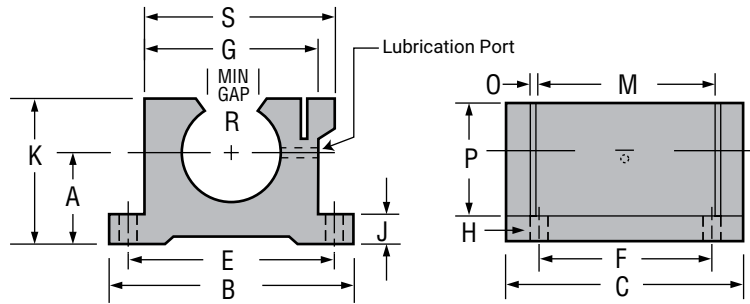

### DIMENSIONAL INFORMATION

Part No.	Nom. Brg. I.D. in.	A Centerline +/- 0.001	B Width	C Length	E +/- 0.010	F +/- 0.010	G		J Flange Thick	K Height	M GRV. Space	O GRV. Width	P GRV. Dia.	R Min Open	S Overall Width	Assem. WT. lb	Load Ratings	
							Body Width	H Bolt Hole									Dynamic C lb	Static Co lb
IPPSN08G	1/2	0.687	2.000	1.50	1.688	1.000	1.375	#6 5/32"	0.250	1.125	1.250	0.046	0.931	0.313	1.438	0.200	230	159
IPPSN10G	5/8	0.875	2.500	1.75	2.125	1.125	1.750	#8 3/16"	0.281	1.438	1.500	0.056	1.197	0.375	1.813	0.400	400	264
IPPSN12G	3/4	0.937	2.750	1.88	2.375	1.250	1.875	#8 3/16"	0.313	1.563	1.625	0.056	1.330	0.438	1.938	0.500	470	372
IPPSN16G	1	1.187	3.250	2.63	2.875	1.750	2.375	#10 7/32"	0.375	1.938	2.250	0.068	1.671	0.563	2.438	1.000	850	667
IPPSN20G	1-1/4	1.500	4.000	3.38	3.500	2.000	3.000	#10 7/32"	0.438	2.500	2.625	0.068	2.122	0.625	3.125	2.100	1230	992
IPPSN24G	1-1/2	1.750	4.750	3.75	4.125	2.500	3.500	1/4" 9/32"	0.500	2.875	3.000	0.086	2.519	0.750	3.625	3.200	1480	1258
IPPSN32G	2	2.125	6.000	4.75	5.250	3.250	43.500	3/8" 13/32"	0.625	3.625	4.000	0.103	3.182	1.000	4.688		2430	2165

Notes: (1) All IPPS series pillow blocks use IPS series self-aligning bearings.  
(2) Includes grease zerk fittings for relubrication.

# Linear Ball Bearings Precision Plus Twin Pillow Blocks with Lubrication Ports

## Closed Twin Pillow Blocks **IPPSW**

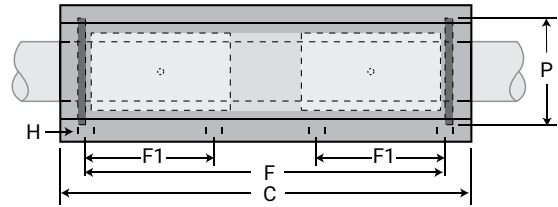
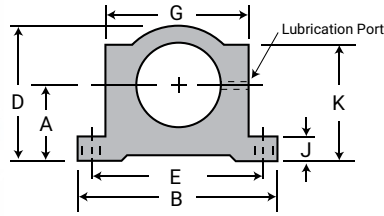

### DIMENSIONAL INFORMATION

Part No.	Nom. Brg. I.D. in.	A Centerline +/- 0.001	B Width	C Length	D Height	E +/- 0.010	F +/- 0.010	F1 +/- 0.010	G Body Width	H		J Flange Thick	K	P GRV. Dia.	Assem. WT. lb	Load Ratings	
										Bolt	Hole					Dynamic C lb	Static Co lb
IPPSW08G	1/2	0.687	2.000	3.500	1.250	1.688	2.500	1.000	1.375	#6	5/32"	0.250	1.125	0.931	0.50	460	318
IPPSW10G	5/8	0.875	2.500	4.000	1.625	2.125	3.000	1.125	1.750	#8	3/16"	0.281	1.438	1.197	1.00	800	528
IPPSW12G	3/4	0.937	2.750	4.500	1.750	2.375	3.500	1.250	1.875	#8	3/16"	0.313	1.563	1.330	1.20	940	744
IPPSW16G	1	1.187	3.250	6.000	2.188	2.875	4.500	1.750	2.375	#10	7/32"	0.375	1.938	1.671	2.20	1700	1334
IPPSW20G	1-1/4	1.500	4.000	7.500	2.813	3.500	5.500	2.000	3.000	#10	7/32"	0.438	2.500	2.122	4.50	2460	1984
IPPSW24G	1-1/2	1.750	4.750	9.000	3.250	4.125	6.500	2.500	3.500	1/4"	9/32"	0.500	2.875	2.519	6.30	2960	2516
IPPSW32G	2	2.125	6.000	10.000	4.063	5.250	8.250	3.250	4.500	3/8"	13/32"	0.625	3.182	2.519?		4860	4330

Notes: (1) All IPPS series pillow blocks use IPS series self-aligning bearings.  
 (2) Includes grease zerk fittings for relubrication.

## Open Twin Pillow Blocks **IPPSWN**

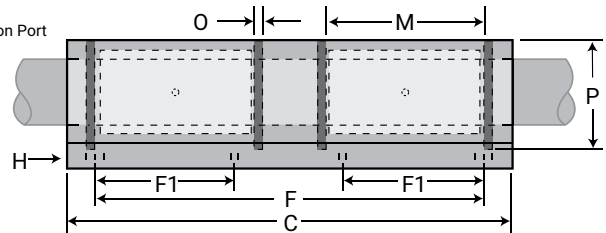
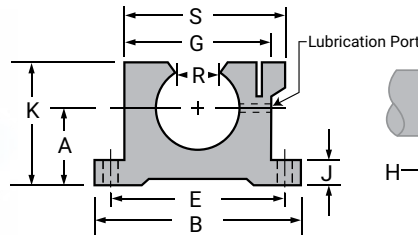

### DIMENSIONAL INFORMATION

Part No.	Nom. Brg. I.D. in.	A Centerline +/- 0.001	B Width	C Length	E +/- 0.010	F +/- 0.010	F1 +/- 0.010	G Body Width	H		J Flange Thick	K Height	M GRV. Space	O GRV. Width	P GRV. Dia.	R MIN Open	S Overall Width	Assem. WT. lb	Load Ratings	
									Bolt	Hole									Dynamic C lb	Static Co lb
IPPSWN08G	1/2	0.687	2.000	3.500	1.688	2.500	1.000	1.375	#6	5/32"	0.250	1.125	1.250	0.046	0.931	0.313	1.438	0.40	460	318
IPPSWN10G	5/8	0.875	2.500	4.000	2.125	3.000	1.125	1.750	#8	3/16"	0.281	1.438	1.500	0.056	1.197	0.375	1.813	0.80	800	528
IPPSWN12G	3/4	0.937	2.750	4.500	2.375	3.500	1.250	1.875	#8	3/16"	0.313	1.563	1.625	0.056	1.330	0.438	1.938	1.00	940	744
IPPSWN16G	1	1.187	3.250	6.000	2.875	4.500	1.750	2.375	#10	7/32"	0.375	1.938	2.250	0.068	1.671	0.563	2.438	2.00	1700	1334
IPPSWN20G	1-1/4	1.500	4.000	7.500	3.500	5.500	2.000	3.000	#10	7/32"	0.438	2.500	2.625	0.068	2.122	0.625	3.125	4.00	2460	1984
IPPSWN24G	1-1/2	1.750	4.750	9.000	4.125	6.500	2.500	3.500	1/4"	9/32"	0.500	2.875	3.000	0.086	2.519	0.750	3.625	6.00	2960	2516
IPPSWN32G	2	2.125	6.000	10.000	5.250	8.250	3.250	4.500	3/8"	13/32"	0.625	3.625	4.000	0.103	3.182	1.000	4.688		4860	4330

Notes: (1) All IPPS series pillow blocks use IPS series self-aligning bearings.  
 (2) Includes grease zerk fittings for relubrication.

INCH

ISO METRIC

JIS METRIC

# Linear Ball Bearings Precision Pillow Blocks

INCH

ISO METRIC

JIS METRIC

## Ball Bearings – Closed Pillow Blocks IPP

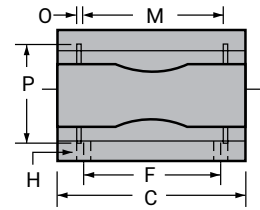
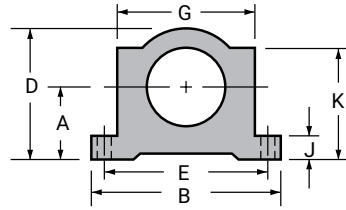
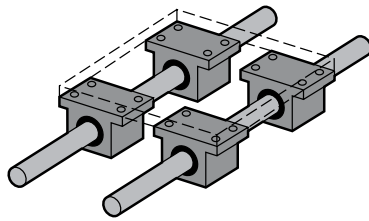

Part No.	Nom. Brg. Dia.	A Centerline +/- 0.001	B Width	C Length	D Height	E +/- 0.010	F +/- 0.010	G Body Width	H		J Flng. Thick	K Height	M GRV. Space	O GRV. Width	P Grv. Dia.	Smalley Ret. Ring Part No.	Assem. WT. lb.	Load Ratings lb	
									Bolt	Hole								Dynamic C	Static Co
IPP04G	1/4	0.437	1.625	1.19	0.813	1.312	0.750	1.000	#6	5/32"	0.188	0.750	0.750	0.039	0.532	WH-51	0.099	46	59
IPP06G	3/8	0.500	1.750	1.31	0.938	1.437	0.875	1.125	#6	5/32"	0.188	0.875	0.875	0.039	0.665	WH-65	0.129	50	70
IPP08G	1/2	0.687	2.000	1.69	1.250	1.688	1.000	1.375	#6	5/32"	0.250	1.125	1.250	0.046	0.931	WH-90	0.250	114	176
IPP10G	5/8	0.875	2.500	1.94	1.625	2.125	1.125	1.750	#8	3/16"	0.281	1.438	1.500	0.056	1.197	WH-115	0.500	174	265
IPP12G	3/4	0.937	2.750	2.06	1.750	2.375	1.250	1.875	#8	3/16"	0.313	1.563	1.625	0.056	1.330	WH-128	0.580	193	307
IPP16G	1	1.187	3.250	2.81	2.188	2.875	1.750	2.375	#10	7/32"	0.375	1.938	2.250	0.068	1.671	WH-156	1.000	220	352
IPP20G	1-1/4	1.500	4.000	3.63	2.813	3.500	2.000	3.000	#10	7/32"	0.438	2.500	2.625	0.068	2.122	WH-200	2.000	352	615
IPP24G	1-1/2	1.750	4.750	4.00	3.250	4.125	2.500	3.500	1/4"	9/32"	0.500	2.875	3.000	0.086	2.519	WH-237	3.000	490	903
IPP32G	2	2.125	6.000	5.00	4.063	5.250	3.250	4.500	3/8"	13/32"	0.625	3.625	4.000	0.103	3.182	WH-300	6.500	858	1784

Notes: (1) Pre-assembled IPP series pillow blocks include self-aligning housing and IP series precision bearings.  
 (2) Straight bore, "B" option must be ordered for non-self aligning pillow block assemblies.

## Ball Bearings – Open Pillow Blocks IPPN

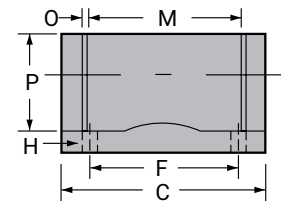
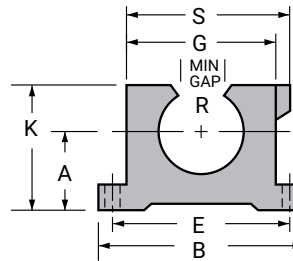
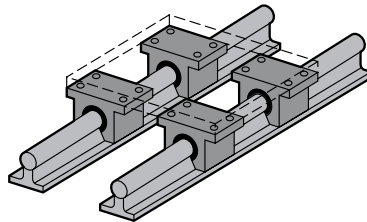

Part No.	Nom. Brg. Dia.	A Centerline +/- 0.001	B Width +/- 0.010	C Length	E +/- 0.010	F +/- 0.010	G Body Width	H		J Flng Thick	K Height	M GRV. Space	O GRV. Width	P GRV. Dia.	R MIN. Open	S Overall Width	Eaton Ret. Ring Part No.	Assem. WT. lb.	Load Ratings lb	
								Bolt	Hole										Dynamic C	Static Co
IPPN08G	1/2	0.687	2.00	1.50	1.688	1.000	1.375	#6	5/32"	0.250	1.125	1.250	0.046	0.931	0.313	1.438	MNAN-87	0.25	114	176
IPPN10G	5/8	0.875	2.50	1.75	2.125	1.125	1.750	#8	3/16"	0.281	1.438	1.500	0.056	1.197	0.375	1.813	MNAN-112	0.50	174	265
IPPN12G	3/4	0.937	2.75	1.88	2.375	1.250	1.875	#8	3/16"	0.313	1.563	1.625	0.056	1.330	0.438	1.938	MNAN-125	0.58	193	307
IPPN16G	1	1.187	3.25	2.63	2.875	1.750	2.375	#10	7/32"	0.375	1.938	2.250	0.068	1.671	0.563	2.438	MNAN-156	1.00	220	352
IPPN20G	1-1/4	1.500	4.00	3.38	3.500	2.000	3.000	#10	7/32"	0.438	2.500	2.625	0.068	2.122	0.625	3.125	MNAN-200	2.00	352	615
IPPN24G	1-1/2	1.750	4.75	3.75	4.125	2.500	3.500	1/4"	9/32"	0.500	2.875	3.000	0.086	2.519	0.750	3.625	MNAN-237	3.00	490	903
IPPN32G	2	2.125	6.00	4.75	5.250	3.250	4.500	3/8"	13/32"	0.625	3.625	4.000	0.103	3.182	1.000	4.688	MNAN-300	6.50	858	1784

Notes: (1) Pre-assembled IPP series pillow blocks include self-aligning housing and IP series precision bearings.  
 (2) Straight bore, "B" option must be ordered for non-self aligning pillow block assemblies.



Simplicity Linear Slides: Pre-Assembled Pillow Block, Shaft, and Support Rail—page 108



Only certified Simplicity 60 Plus Shafting provides maximum linear bearing performance.

Inch Series—page 52 Metric Series—page 90

# Linear Ball Bearings Precision Twin Pillow Blocks

## Ball Bearings – Twin Closed Pillow Blocks IPPW

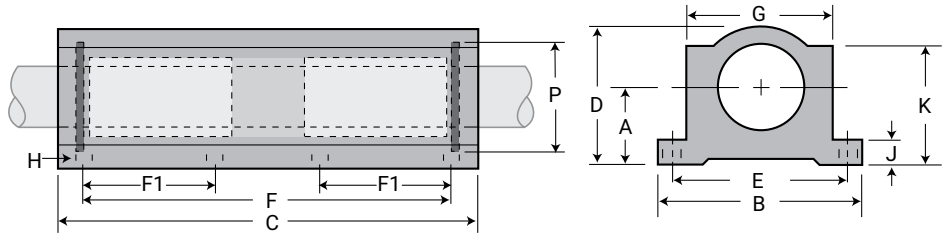

Part No.	Nom. Brg. Dia.	A Centerline +/-0.001	B Width	C Length	D Height	E +/-0.010	F +/-0.010	F1 +/-0.010	G Body Width	H Bolt	J Hole	K Thick	P Grv. Dia	Smalley Ret. Ring Part No.	Assem. WT. lb.	Load Ratings lb		
																Dynamic C	Static Co	
IPPW04G	1/4	0.437	1.625	2.50	0.813	1.312	2.000	.750	1.000	#6	5/32"	0.188	0.750	0.532	WH-51	0.197	92	118
IPPW06G	3/8	0.500	1.750	2.75	0.938	1.437	2.250	.875	1.125	#6	5/32"	0.188	0.875	0.665	WH-65	0.258	100	140
IPPW08G	1/2	0.687	2.000	3.50	1.250	1.688	2.500	1.000	1.375	#6	5/32"	0.250	1.125	0.931	WH-90	0.500	228	352
IPPW10G	5/8	0.875	2.500	4.00	1.625	2.125	3.000	1.125	1.750	#8	3/16"	0.281	1.438	1.197	WH-115	1.000	348	530
IPPW12G	3/4	0.937	2.750	4.50	1.750	2.375	3.500	1.250	1.875	#8	3/16"	0.313	1.563	1.330	WH-128	1.125	386	614
IPPW16G	1	1.187	3.250	6.00	2.188	2.875	4.500	1.750	2.375	#10	7/32"	0.375	1.938	1.671	WH-156	2.188	440	704
IPPW20G	1-1/4	1.500	4.000	7.50	2.813	3.500	5.500	2.000	3.000	#10	7/32"	0.438	2.500	2.122	WH-200	4.250	704	1230
IPPW24G	1-1/2	1.750	4.750	9.00	3.250	4.125	6.500	2.500	3.500	1/4"	9/32"	0.500	2.875	2.519	WH-237	6.375	980	1806
IPPW32G	2	2.125	6.000	10.00	4.063	5.250	8.250	3.250	4.500	3/8"	13/32"	0.625	3.625	3.182	WH-300	13.500	1716	3568

Notes: (1) Pre-assembled IPP series pillow blocks include self-aligning housing and IP series precision bearings.  
 (2) Straight bore, "B" option must be ordered for non-self aligning pillow block assemblies.

## Ball Bearings – Twin Open Pillow Blocks IPPWN

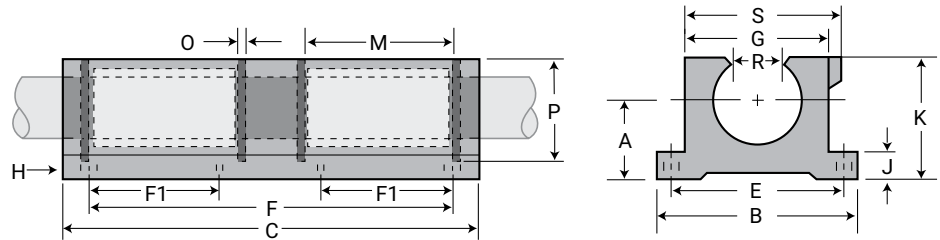

Part No.	Nom. Brg. Dia.	A Centerline +/-0.001	B Width	C Length	E +/-0.010	F +/-0.010	F1 +/-0.010	G Body Width	H Bolt	J Fling. Thick	K Height	M GRV. Space	O GRV. Wide	P GRV. Dia.	R MIN. Open	S Overall Width	Eaton Ret. Ring Part No.	Assem. WT. lb.	Load Ratings lb		
																			Dynamic C	Static Co	
IPPWN08G	1/2	0.687	2.00	3.500	1.688	2.500	1.000	1.375	#6	5/32"	0.250	1.125	1.250	0.046	0.931	0.313	1.438	MNAN-87	0.400	228	352
IPPWN10G	5/8	0.875	2.50	4.000	2.125	3.000	1.125	1.750	#8	3/16"	0.281	1.438	1.500	0.056	1.197	0.375	1.813	MNAN-112	0.910	348	530
IPPWN12G	3/4	0.937	2.75	4.500	2.375	3.500	1.250	1.875	#8	3/16"	0.313	1.563	1.625	0.056	1.330	0.438	1.938	MNAN-125	1.060	386	614
IPPWN16G	1	1.187	3.25	6.000	2.875	4.500	1.750	2.375	#10	7/32"	0.375	1.938	2.250	0.068	1.671	0.563	2.438	MNAN-156	1.970	440	704
IPPWN20G	1-1/4	1.500	4.00	7.500	3.500	5.500	2.000	3.000	#10	7/32"	0.438	2.500	2.625	0.068	2.122	0.625	3.125	MNAN-200	3.725	704	1230
IPPWN24G	1-1/2	1.750	4.75	9.000	4.125	6.500	2.500	3.500	1/4"	9/32"	0.500	2.875	3.000	0.086	2.519	0.750	3.625	MNAN-237	5.800	980	1806
IPPWN32G	2	2.125	6.00	10.00	5.250	8.250	3.250	4.500	3/8"	13/32"	0.625	3.625	4.000	0.103	3.182	1.000	4.688	MNAN-300	12.125	1716	3568

Notes: (1) Pre-assembled IPP series pillow blocks include self-aligning housing and IP series precision bearings.  
 (2) Straight bore, "B" option must be ordered for non-self aligning pillow block assemblies.

INCH  
ISO METRIC  
JIS METRIC

# Linear Ball Bearings Double Wide

## Double Wide Ball Bearings IP-W

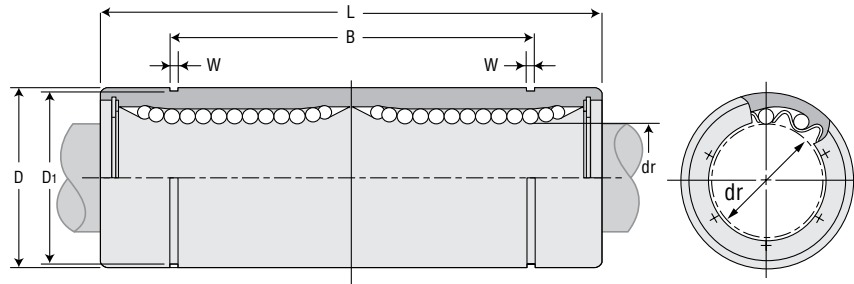

### DIMENSIONAL INFORMATION

(Standard Steel Finish)

Part No.	Nominal Diameter			Ball Circuit	Weight G	Major Dimensions & Tolerances					
	Size in.	dr in.	Tolerance in.			D in.	Tolerance in.	L in.	Tolerance in.	B in.	Tolerance in.
IP04GW	1/4	0.250	0/-0.0004	4	18	0.5000	0/-0.00050	1.3750	0/-0.012	1.0220	0/-0.012
IP06GW	3/8	0.375	0/-0.0004	4	28	0.6250	0/-0.00065	1.5938	0/-0.012	1.2716	0/-0.012
IP08GW	1/2	0.500	0/-0.0004	4	80	0.8750	0/-0.00065	2.3750	0/-0.012	1.9250	0/-0.012
IP10GW	5/8	0.625	0/-0.0004	4	160	1.1250	0/-0.00065	2.8125	0/-0.012	2.2079	0/-0.012
IP12GW	3/4	0.750	0/-0.0005	5	195	1.2500	0/-0.00075	3.0937	0/-0.012	2.3314	0/-0.012
IP16GW	1	1.000	0/-0.0005	6	410	1.5625	0/-0.00075	4.2813	0/-0.016	3.5094	0/-0.16
IP20GW	1-1/4	1.250	0/-0.0006	6	820	2.0000	0/-0.00090	5.0000	0/-0.016	4.0094	0/-0.16
IP24GW	1-1/2	1.500	0/-0.0006	6	1250	2.3750	0/-0.00090	5.6875	0/-0.016	4.8236	0/-0.16
IP32GW	2	2.000	0/-0.0006	6	2350	3.0000	0/-0.00100	7.7500	0/-0.016	6.3834	0/-0.16

Part No.	Nominal Diameter			Major Dimensions & Tolerances			Load Ratings	
	Size in.	dr in.	Tolerance in.	W in.	D1 in.	MAX Eccentricity in.	Dynamic C lb.	Static Co lb.
IP04GW	1/4	0.250	0/-0.0004	0.0390	0.4687	0.0006	72	119
IP06GW	3/8	0.375	0/-0.0004	0.0390	0.5880	0.0006	79	142
IP08GW	1/2	0.500	0/-0.0004	0.0459	0.8209	0.0005	182	352
IP10GW	5/8	0.625	0/-0.0004	0.0559	1.0590	0.0005	276	528
IP12GW	3/4	0.750	0/-0.0005	0.0559	1.1760	0.0007	307	615
IP16GW	1	1.000	0/-0.0005	0.0679	1.4687	0.0007	352	705
IP20GW	1-1/4	1.250	0/-0.0006	0.0679	1.8859	0.0009	562	1234
IP24GW	1-1/2	1.500	0/-0.0006	0.0859	2.2389	0.0009	771	1807
IP32GW	2	2.000	0/-0.0006	0.1029	2.8379	0.0011	1366	3574



Only certified Simplicity 60 Plus Shafting provides maximum linear bearing performance.

Inch Series—page 52 Metric Series—page 90

# Roller Pillow Block Bearings Overview

## Roller Pillow Blocks

The Roller Pillow Block provides key performance benefits such as high load capacities, high speeds, and design compatibility—providing size interchangeability with industry standard blocks. In contaminated environments, the roller bearings push particulates out of the way or roll seamlessly over them. Large rollers in the Roller Pillow Block system are well suited for long travel applications, minimizing vibration and providing smooth and quiet travel over joined shafts.

The Roller Pillow Block solution is available for shaft diameters from 0.5”–3.0” and in three standard configurations; single, double, and twin. This provides dynamic load ratings ranging from 800 to 12500 pounds, a low coefficient of friction, and high speed capabilities.

The Roller Pillow Block system is well suited for a wide range of applications, including material handling, transfer lines, welding equipment, architectural and structural doors, and much more.

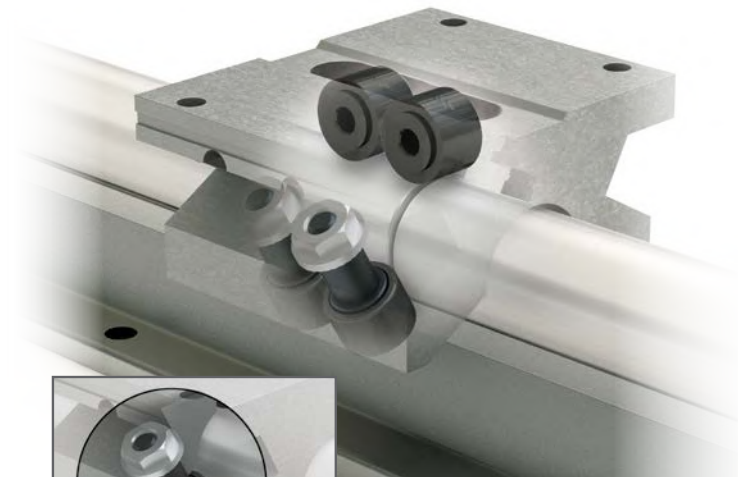

**Eccentric bearing adjustment enables fine-tuned adjustments**

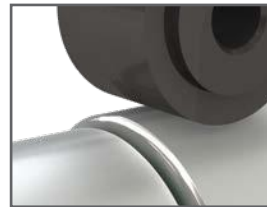

**Large cam follower navigates joined shafts and rail assemblies with ease**

- Designed for high loads and/or speeds
- Loads up to 12,500 pounds
- Simplified installation and alignment
- Self-aligning
- Adjustable
- Superior for joined rail applications
- Standard mounting holes
- Interchangeability with industry standards
- Re-buildable
- Visit [pbclinear.com](http://pbclinear.com) to configure a product solution with our configurator



# Roller Pillow Block Bearings Overview

## Reliability

- Large cam follower design with side seals delivers superior contaminant resistance
- Excels in long travel joined shafts or rail assemblies
- Accessories such as lubrication ports and scrapers available for ease of maintenance and maximum life



Roller pillow block's large cam follower navigates joined shafts and rail assemblies with ease



Watch the product overview video

Misalignment of shafts due to installation procedures or non-matched shafts can lead to premature or catastrophic ball bearing failures

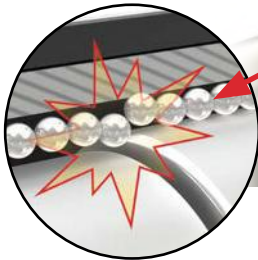

## High Performance

- Speeds up to 2.5 times faster than a linear ball bearing pillow block
- Higher dynamic load capacity compared to industry standard linear ball bearing pillow blocks
- Smoother travel equals lower vibration and noise

### Dynamic Load Ratings

#### Shaft Diameter

1"	1½"	2"
----	-----	----



### Open-Style Ball Bearing

220 lb	490 lb	858 lb
--------	--------	--------

### Single Roller Pillow Block



955 lb	1,660 lb	2,400 lb
--------	----------	----------

### Double & Twin Roller Pillow Block



1,910 lb	3,320 lb	4,800 lb
----------	----------	----------

Dynamic load rating for a 3" shaft would be 6,260 lb for the Single Roller Pillow Block and 12,520 lb for the Double and Twin Roller Pillow Block.

PERFORMANCE

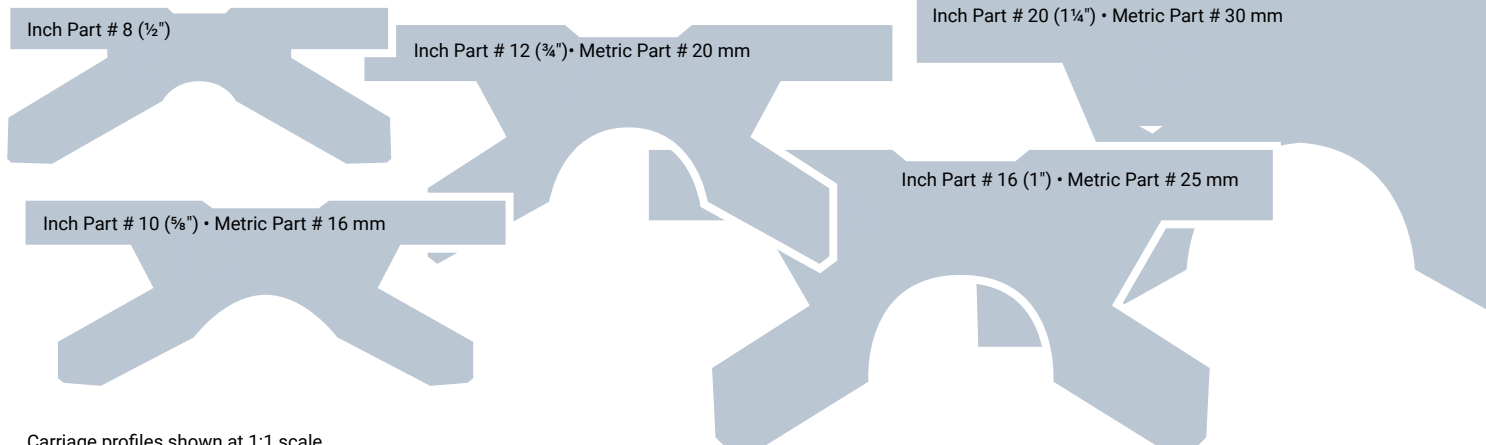

Carriage profiles shown at 1:1 scale.

# Roller Pillow Block Bearings Overview

## Lower System Cost

- Simplified installation and alignment
- Floating pillow block option available accommodating up to 0.125" out-of-parallelism, reducing installation time and cost dramatically
- Simple eccentric bearing adjustment allows for tailored bearing fit to application requirements

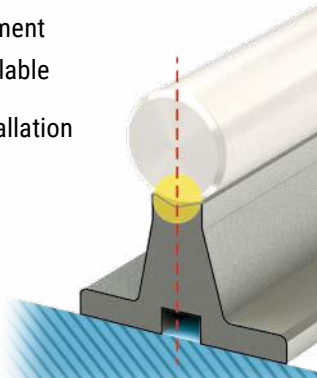

V-block shaped support rail design aligns shaft centerlines simplifying joined rail assemblies

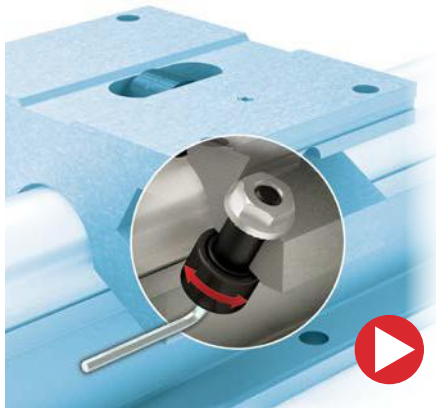

Watch the Roller Pillow Block adjustment video

Eccentric bearing adjustment enables fine-tuned adjustments

## Design Compatibility

- Interchangeability to industry standard mounting holes and centerlines for linear bearing pillow blocks from leading competitors

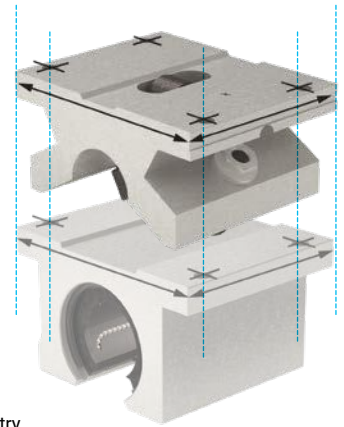
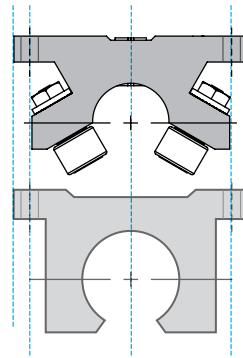

PBC Linear Roller Pillow Block is industry standard interchangeable, simplifying replacement and lowering costs

**Note:** When a linear ball bearing failure occurs, the shafting is easily damaged and needs to be replaced. When using the roller pillow block, that is not always the case. Consult factory for details.

Inch Part # 48 (3")

Inch Part # 32 (2")

Inch Part # 24 (1½")

PERFORMANCE

# Roller Pillow Block Applications

## Welding Machines

Roller Pillow Blocks are corrosion resistant and handle loads up to 12,500 lbs, providing the industrial strength linear motion required in welding applications. The low-friction rollers easily navigate joined or misaligned shafts and also account for shaft deflection.

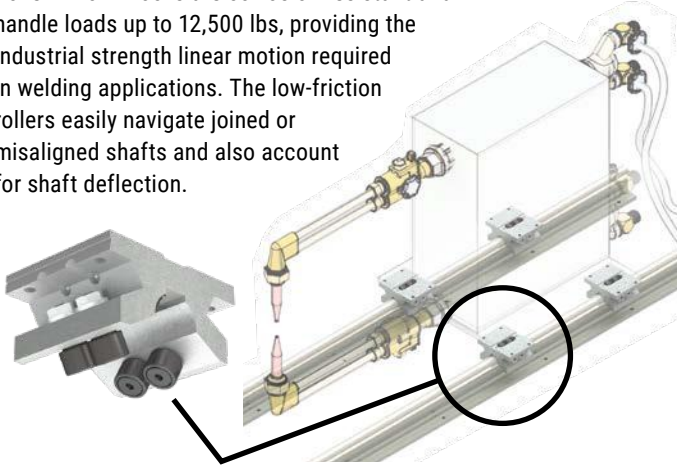

## Industrial Stop Gauge & Push Feed System

The twin Roller Pillow Block provides the rigidity of a heavy duty bearing system for band saws, punches, bending machines, and brakes. Double and twin Roller Pillow Blocks are ideal for applications requiring high load capacities with long life.

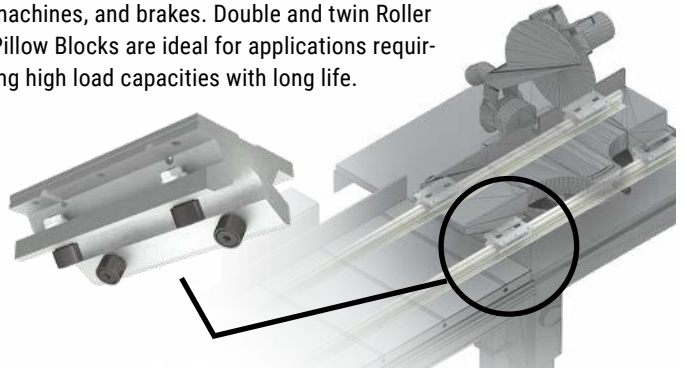

## Rack Systems & Industrial Container Mobility



The Roller Pillow Block system carries heavy loads and easily maneuvers over joined or misaligned shafts over long travels. The system is corrosion resistant and provides high speeds and rigidity in the toughest applications.

Roller Bearings move smoothly over misaligned and joined shafts over long travels.



## Sliding Doors

Roller Pillow Block systems provide smooth and quiet travel in a wide range of environments.

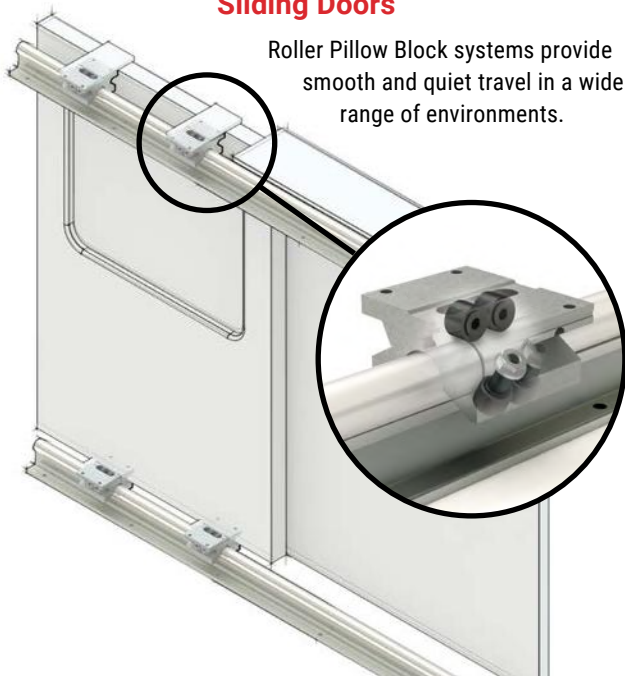

## Pipe Mill

Roller Pillow Blocks provide smooth linear motion in the toughest environments. Large cam followers, equipped with side seals, deliver industrial strength performance over long travel lengths and excel in dirty environments.

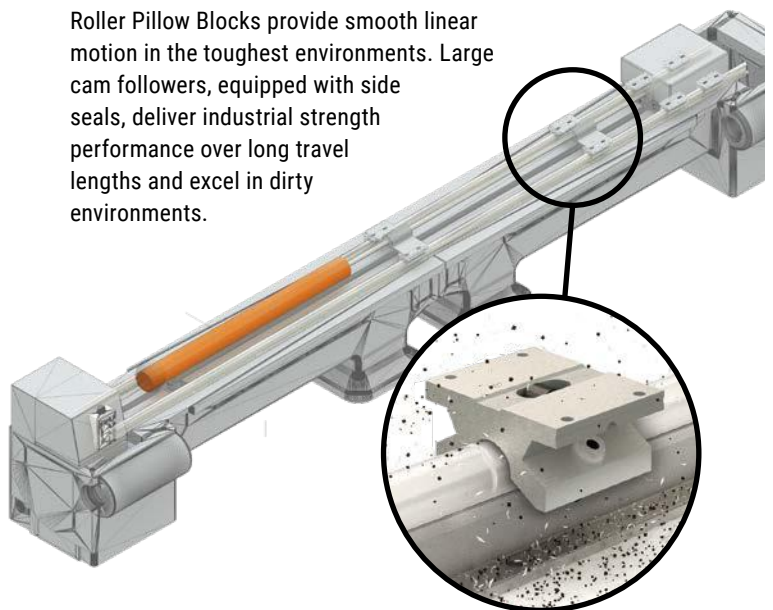

PERFORMANCE

# Roller Pillow Block Bearings

## Single Roller Pillow Block SPB-OPN

Low friction single Roller Pillow Blocks are selected for standard linear movement or for situations with shaft deflection. Self-aligning Roller Pillow Blocks can handle a half of a degree in misalignment.

**Note:** To learn more about turning a curve with a single Roller Pillow Block, please reference the technical information on page 156.

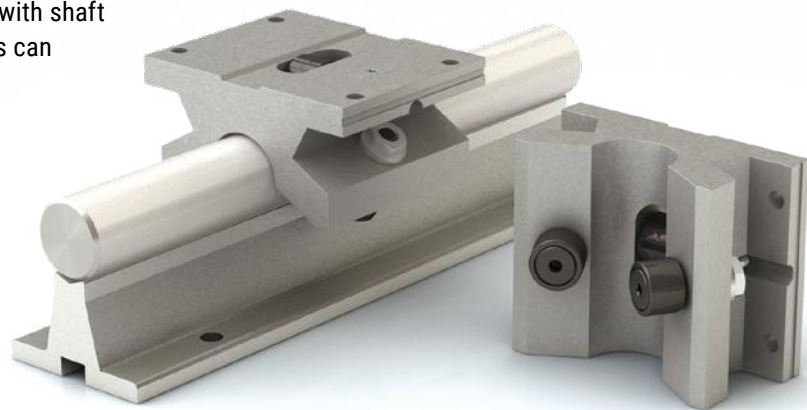

Configure  
Online

INCH

ISO METRIC

JIS METRIC

### Dimensions and Load Ratings Inch Shafting

Part Number	Shaft Diameter	DYN. Load Rating	Weight	A	B	C	D	E	F	G	H		J	K
	in.			lb.	lb.	±0.003	in.	in.	in.	±0.005	±0.005	in.	Bolt	Hole
SPB-08-OPN	1/2	400	0.40	0.687	2.000	1.500	1.156	1.688	1.000	1.000	#6	0.1563	0.240	0.313
SPB-10-OPN	5/8	500	0.50	0.875	2.500	1.750	1.406	2.125	1.125	1.063	#8	0.1875	0.270	0.375
SPB-12-OPN	3/4	600	0.60	0.937	2.750	1.875	1.563	2.375	1.250	1.063	#8	0.1875	0.303	0.438
SPB-16-OPN	1	955	1.00	1.187	3.254	2.625	2.000	2.875	1.750	1.375	#10	0.2188	0.360	0.688
SPB-20-OPN	1-1/4	1400	2.00	1.500	4.000	3.375	2.563	3.500	2.000	1.750	#10	0.2188	0.424	0.813
SPB-24-OPN	1-1/2	1660	2.80	1.750	4.750	3.750	2.875	4.125	2.500	1.875	1/4	0.2813	0.474	1.063
SPB-32-OPN	2	2400	5.00	2.125	6.000	4.750	3.500	5.250	3.250	2.500	3/8	0.4063	0.600	1.375
SPB-48-OPN	3	6260	14.00	3.500	8.375	5.500	5.500	7.000	4.000	3.875	5/8	0.6563	1.000	2.125

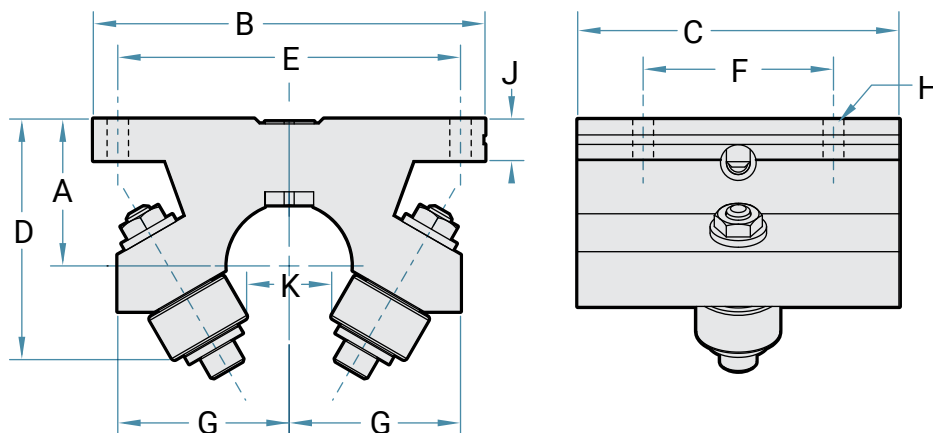

# Roller Pillow Block Bearings

## Double Roller Pillow Block DPB-OPN

Double the capacity of the Single Roller Pillow Block. The double Roller Pillow Blocks offer twice the dynamic load rating in a similar mounting footprint. The Double Roller Pillow Blocks are used when longer travel life or an increase in load capacity is required.



Configure Online

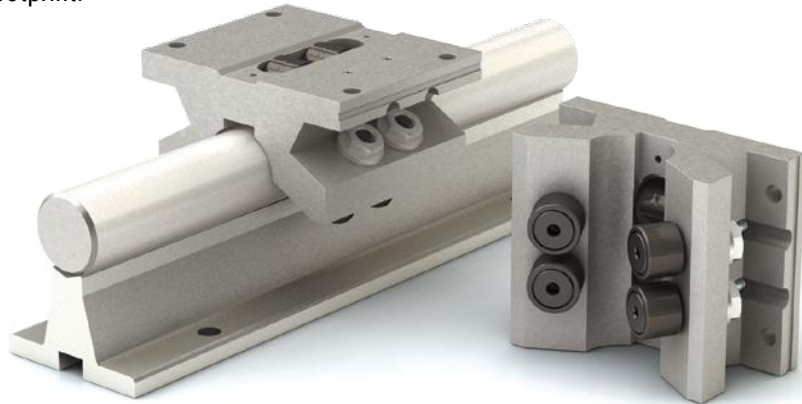

Dimensions and Load Ratings Inch Shafting

Part Number	Shaft Diameter in.	DYN. Load Rating lb.	Weight lb.	A	B	C	D	E	F	G	H		J	K	L
				±0.003	in.	in.	in.	±0.005	±0.005	in.	Bolt	Hole	in.	in.	in.
DPB-08-OPN	1/2	800	0.50	0.687	2.000	2.000	1.156	1.688	1.625	1.000	#6	0.1563	0.240	0.313	0.562
DPB-10-OPN	5/8	1000	0.70	0.875	2.500	2.500	1.406	2.125	2.000	1.063	#8	0.1875	0.270	0.375	0.526
DPB-12-OPN	3/4	1200	0.80	0.937	2.750	2.625	1.563	2.375	1.250	1.063	#8	0.1875	0.300	0.438	0.562
DPB-16-OPN	1	1910	1.20	1.187	3.254	2.625	2.000	2.875	1.750	1.375	#10	0.2188	0.360	0.688	0.720
DPB-20-OPN	1-1/4	2800	2.30	1.500	4.000	3.375	2.563	3.500	2.000	1.750	#10	0.2188	0.424	0.813	0.937
DPB-24-OPN	1-1/2	3320	3.00	1.750	4.750	3.750	2.875	4.125	2.500	1.875	1/4	0.2813	0.474	1.063	0.937
DPB-32-OPN	2	4800	5.50	2.125	6.000	4.750	3.500	5.250	3.250	2.500	3/8	0.4063	0.603	1.375	1.187
DPB-48-OPN	3	12520	20.00	3.500	8.375	7.250	5.500	7.000	5.875	3.875	5/8	0.6563	1.000	2.125	2.080

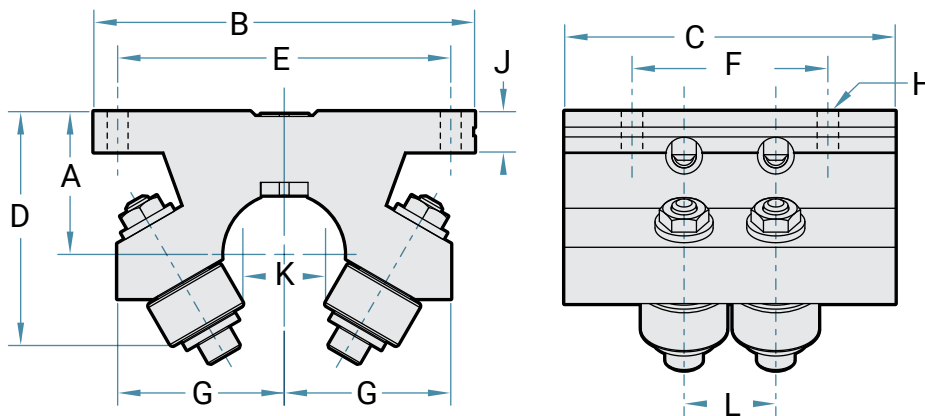

# Roller Pillow Block Bearings

## Twin Roller Pillow Block **TWN-OPN**

The Twin Roller Pillow Block load rating is the same as the double and is a good choice when using only one Roller Pillow Block per shaft. The twin model also offers an additional pair of mounting holes.



Configure  
Online

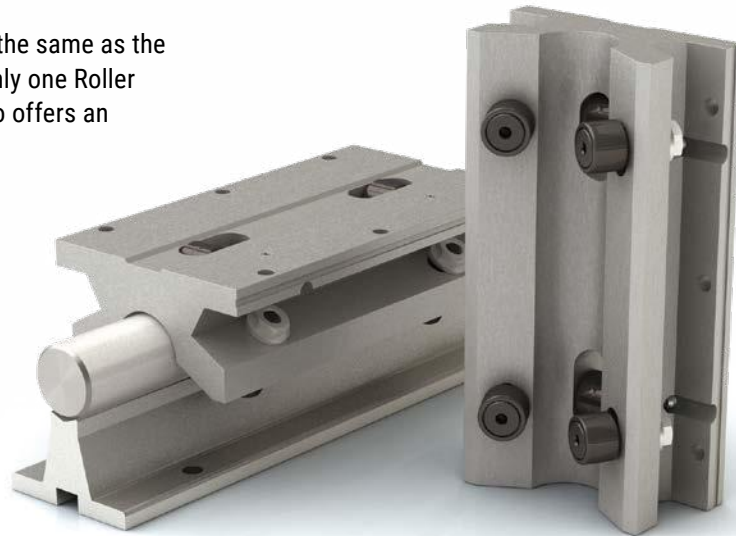

INCH

ISO METRIC

JIS METRIC

Dimensions and Load Ratings Inch Shafting

Part Number	Shaft Diameter	DYN. Load Rating	Weight	A	B	C	D	E	F	G	H		J	K	L
	in.			lb.	lb.	±0.003	in.	in.	in.	±0.005	±0.005	in.	Bolt	Hole	in.
TWN-08-OPN	1/2	800	0.80	0.687	2.000	3.50	1.156	1.688	2.50	1.000	#6	0.1563	0.240	0.313	1.500
TWN-10-OPN	5/8	1000	1.00	0.875	2.500	4.00	1.406	2.125	3.00	1.063	#8	0.1875	0.270	0.375	2.125
TWN-12-OPN	3/4	1200	1.20	0.937	2.750	4.50	1.563	2.375	3.50	1.063	#8	0.1875	0.300	0.438	2.500
TWN-16-OPN	1	1910	2.30	1.187	3.254	6.00	2.000	2.875	4.50	1.375	#10	0.2188	0.360	0.688	3.750
TWN-20-OPN	1-1/4	2800	4.40	1.500	4.000	7.50	2.563	3.500	5.50	1.750	#10	0.2188	0.424	0.813	4.625
TWN-24-OPN	1-1/2	3320	6.50	1.750	4.750	9.00	2.875	4.125	6.50	1.875	1/4	0.2813	0.474	1.063	5.500
TWN-32-OPN	2	4800	12.40	2.125	6.000	12.00	3.500	5.250	10.50	2.500	3/8	0.4063	0.600	1.375	8.250

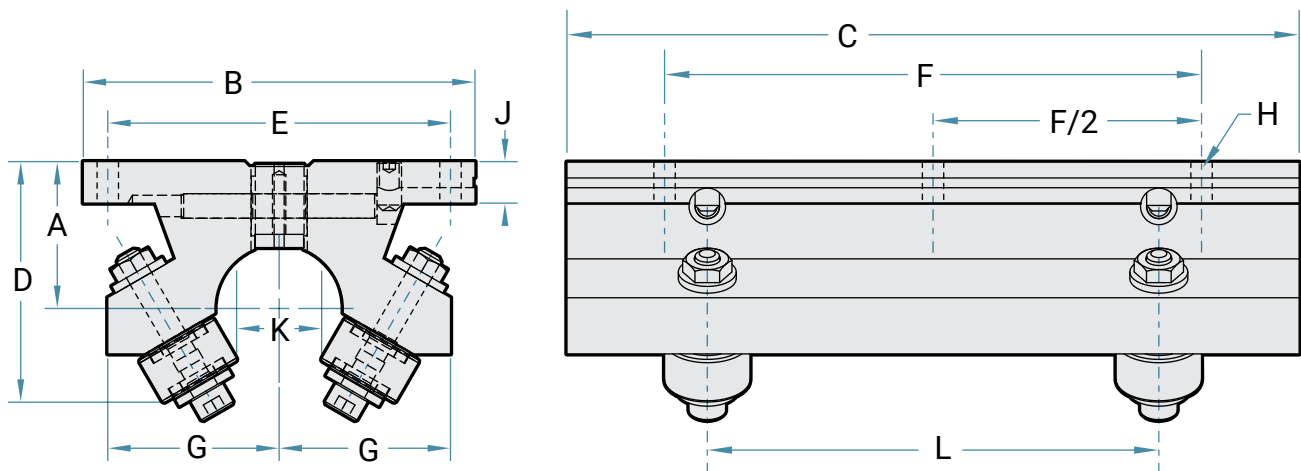

# Roller Pillow Block Accessories

INCH

ISO METRIC

JIS METRIC

## Top Grease Option

Roller Pillow Block rollers are lubricated and sealed. In some applications it is desired to re-grease the main support roller. The top grease option can help achieve full bearing life in applications that reduce or contaminate the grease of the roller. Such conditions may exist in applications where solvents or contaminants leach out the grease through the vents in the seals, or where contaminants are so fine or extreme they must be purged out of the roller with fresh grease. The top grease option is also recommended when high speeds or high temperatures are present. The top grease option is available on pillow blocks that are 1-1/4" or larger.

To order, add the suffix, "TG" after the pillow block model number.

**Note:** Shock, vibration, and moments may affect the life of the pillow block.

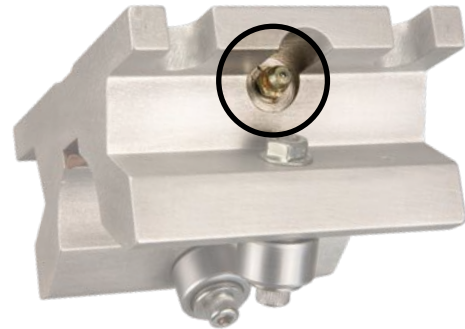
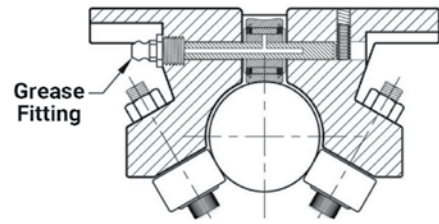

## Floating Option

The only product on the market that addresses the non-parallel shafting problem is a Roller Pillow Block with the floating option. Also useful when trying to align long shafts, floating Roller Pillow Blocks should be used on one shaft with the standard pillow block on the other. Special grease is included for the grooves on top of each floating pillow block.

During installation do not over-tighten the mounting bushings as this will cause them to bind.

To order, add the prefix, "F-" to the single, double, or twin Roller Pillow Block number.

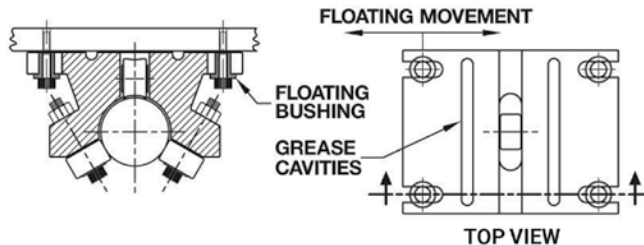

Pillow Block Size	Floating Movement
8	0.0625"
10	0.0625"
12	0.0625"
16	0.0938"
20	0.1250"
24	0.1250"
32	0.1563"
48	0.1875"
64	0.1875"

## Scraper Option

Reduce the amount of dirt accumulation that lands on the top of the Roller Pillow Block shaft with the scraper option. Available only on specially machined pillow blocks, the scraper is mounted to each end of the bearing assembly to clean the shaft in either direction. Made from spring-tempered beryllium copper that conforms to the shaft diameter, the scraper will perform successfully after a short break in period. Scraper model is not available as a retrofit.

To order this option, add the suffix "-S" after the pillow block model number.

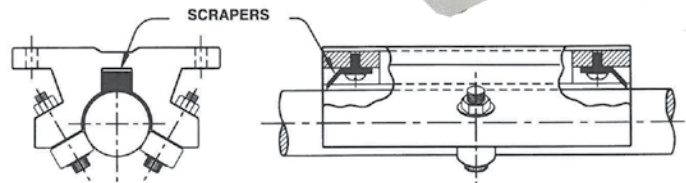
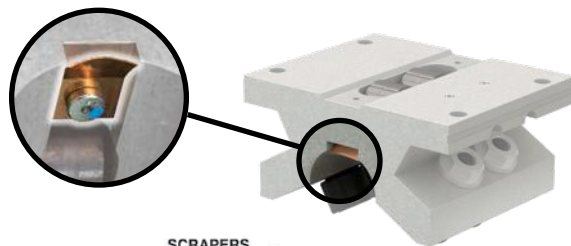

# Roller Pillow Block Accessories

## Linear Carriage Lock

The linear carriage lock is a positive locking device for linear slides, carriages, and bearings.

The locks are:

- Self-centering
- Corrosion resistant
- Strong holding
- Contaminant resistant
- Easily mounted
- Maintenance-free

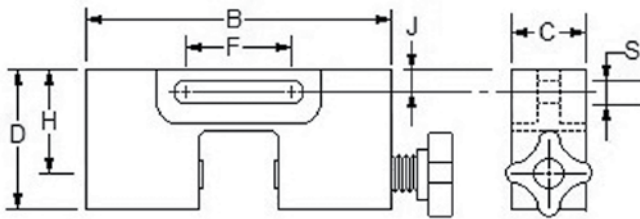
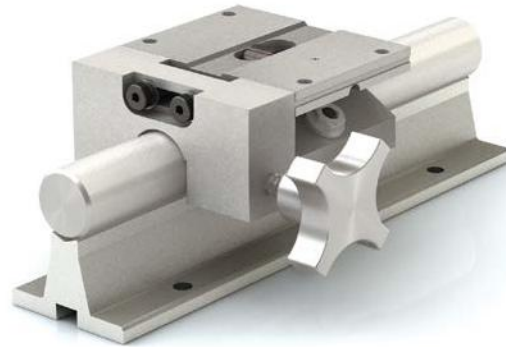

Part Number	Shaft Diameter in.	D in.	B in.	C in.	J in.	F in.	H in.	S in.
LCL-08	1/2	0.92	2.00	1	0.22	0.81	0.69	0.26
LCL-12	3/4	1.25	2.75	1	0.22	0.81	0.94	0.26
LCL-16	1	1.60	3.25	1	0.27	0.81	1.18	0.26
LCL-24	1-1/2	2.29	4.75	1	0.40	0.81	1.75	0.26
LCL-32	2	2.85	6.00	1	0.50	1.25	2.13	0.50

**Note:** When ordering with a Roller Pillow Block that it will be mounted to, just add "-LCL" to the Roller Pillow Block part number (EX: SPB-12-0PN-LCL)

## Pillow Block Rebuild Kits

The Roller Pillow Block rebuild kit contains all the parts required for a complete unit rebuild:

- One fixed side roller
- One eccentric side roller
- One top support roller
- One top roller axle
- One set screw



FUBK08-16

FUBK20-48

Part Number	Shaft Diameter	
	inch	metric
FUBK08	1/2"	12 mm
FUBK10	5/8"	16 mm
FUBK12	3/4"	20 mm
FUBK16	1"	25 mm
FUBK20	1-1/4"	30 mm
FUBK24	1-1/2"	N/A
FUBK32	2"	N/A
FUBK48	3"	N/A

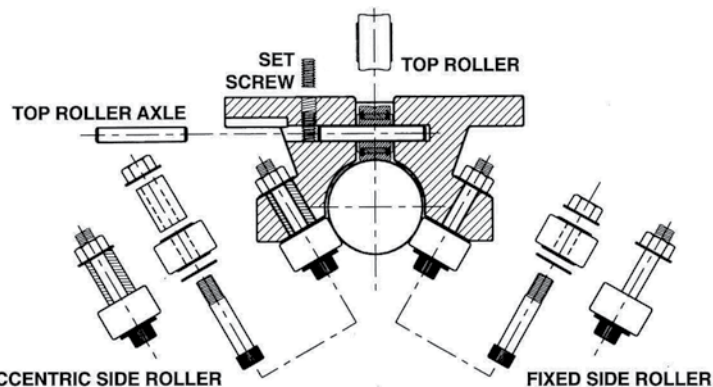

To rebuild a Double or Twin Roller Pillow Block, please order 2 kits.

All parts of a Roller Pillow Block should be replaced before re-installation.

# Shaft & Rail Systems

INCH

ISO METRIC

JIS METRIC

## Shaft & Rail Systems

PBC Linear offers shaft and rail systems composed of world-class linear motion components in six standard configurations in four different sizes.

These systems also come with the option of carriage plates with or without mounted pillow blocks.

## Support Block System

Support block systems are manufactured with Roller Pillow Block(s), 60 Plus® precision case hardened and ground shaft, and two steel support blocks.

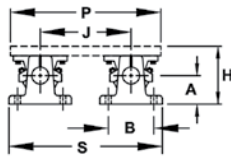
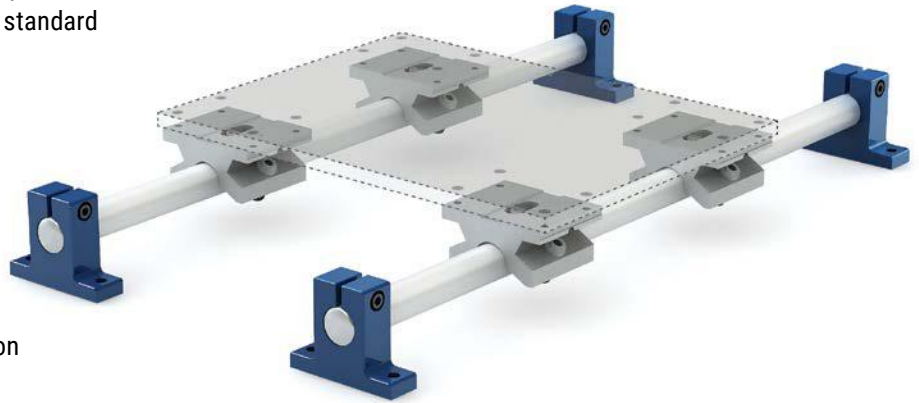

Support Block System  
End View

Single Pillow Block System  
Part Number Prefix: **S1S**

Double Pillow Block System  
Part Number Prefix: **S1D**

Twin Pillow Block System  
Part Number Prefix: **S1T**

## Technical Information

Type Roller Pillow Block	Part Number	Shaft Diameter in.	Total Basic Dynamic Rating lb.	Number Roller Pillow Blocks	Number Support Blocks	Number Hardened Shafts	A in.	B in.	G in.	H in.	J in.	K in.	P in.	S in.
Single	<b>S1S08</b>	0.50	800	2	2	1	1.00	2.00	1.63	2.187	3.25	0.63	5.50	5.25
Double	<b>S1D08</b>	0.50	1600	2	2	1	1.00	2.00	1.63	2.187	3.25	0.63	5.50	5.25
Twin	<b>S1T08</b>	0.50	800	1	2	1	1.00	2.00	1.63	2.187	3.25	0.63	5.50	5.25
Single	<b>S1S12</b>	0.75	1200	2	2	1	1.25	2.75	2.13	2.937	4.50	0.75	7.50	7.25
Double	<b>S1D12</b>	0.75	2400	2	2	1	1.25	2.75	2.13	2.937	4.50	0.75	7.50	7.25
Twin	<b>S1T12</b>	0.75	1200	1	2	1	1.25	2.75	2.13	2.937	4.50	0.75	7.50	7.25
Single	<b>S1S16</b>	1.00	1910	2	2	1	1.50	3.25	2.63	3.437	5.50	1.00	9.00	8.75
Double	<b>S1D16</b>	1.00	3820	2	2	1	1.50	3.25	2.63	3.437	5.50	1.00	9.00	8.75
Twin	<b>S1T16</b>	1.00	1910	1	2	1	1.50	3.25	2.63	3.437	5.50	1.00	9.00	8.75
Single	<b>S1S24</b>	1.50	3320	2	2	1	2.00	4.75	3.50	5.000	8.00	1.25	13.00	12.75
Double	<b>S1D24</b>	1.50	6640	2	2	1	2.00	4.75	3.50	5.000	8.00	1.25	13.00	12.75
Twin	<b>S1T24</b>	1.50	3320	1	2	1	2.00	4.75	3.50	5.000	8.00	1.25	13.00	12.75

# Shaft & Rail Systems

INCH

ISO METRIC

JIS METRIC

## Support Rail Systems

Support rail systems are manufactured with Roller Pillow Blocks and 60 Plus® precision case hardened and ground shaft that is mounted on a continuous aluminum support rail. To prevent the carriage from sliding off the shaft, end stops can be purchased.

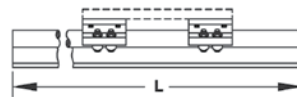
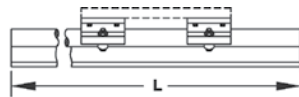
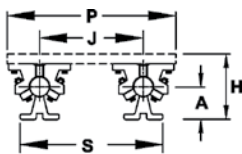
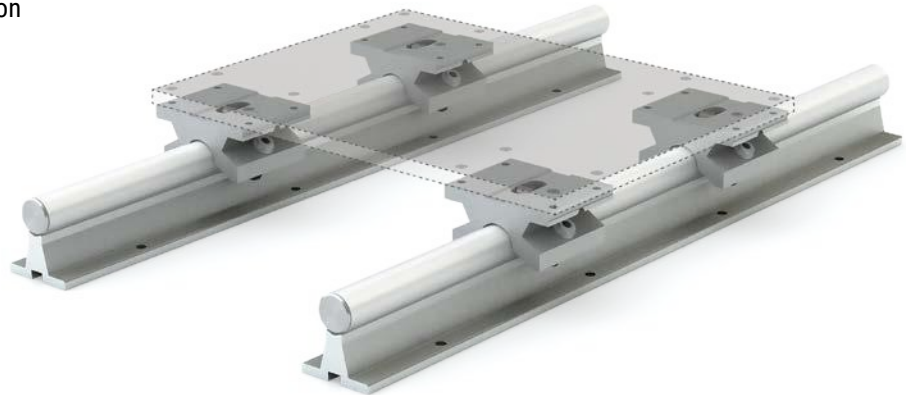

End View

Single Pillow Block System  
Part Number Prefix: **S2S**

Double Pillow Block  
Part Number Prefix: **S2D**

Twin Pillow Block  
Part Number Prefix: **S2T**

## Technical Information

Type Roller Pillow Block	Part Number	Shaft Diameter in.	Total Basic Dynamic Rating lb.	Number Roller Pillow Blocks	Number Continuous Support Rail	Number Hardened Shafts	A in.	H in.	J in.	P in.	S in.
Single	S2S08	1/2	800	2	1	1	1.125	2.187	3.25	5.5	4.75
Double	S2D08	1/2	1600	2	1	1	1.125	2.187	3.25	5.5	4.75
Twin	S2T08	1/2	800	1	1	1	1.125	2.187	3.25	5.5	4.75
Single	S2S12	3/4	1200	2	1	1	1.500	2.937	4.50	7.5	6.25
Double	S2D12	3/4	2400	2	1	1	1.500	2.937	4.50	7.5	6.25
Twin	S2T12	3/4	1200	1	1	1	1.500	2.937	4.50	7.5	6.25
Single	S2S16	1	1910	2	1	1	1.750	3.437	5.50	9.0	7.63
Double	S2D16	1	3820	2	1	1	1.750	3.437	5.50	9.0	7.63
Twin	S2T16	1	1910	1	1	1	1.750	3.437	5.50	9.0	7.63
Single	S2S24	1-1/2	3320	2	1	1	2.500	5.000	8.00	13.0	11.00
Double	S2D24	1-1/2	6640	2	1	1	2.500	5.000	8.00	13.0	11.00
Twin	S2T24	1-1/2	3320	1	1	1	2.500	5.000	8.00	13.0	11.00

## Simplicity 60 Plus® Shafting

PBC Linear® formulated a linear shaft designed specifically for optimal bearing performance – 60 Plus Shafting. Advanced process capabilities maintain the ideal surface finish for linear bearings resulting in the longest life and highest performing shaft-to-bearing combination available:

Optimized surface finish

Faster break-in and better Frelon® transfer for plain bearings

Longest life possible, less down time and maintenance

Straight to within 0.001" to 0.002" per foot cumulative, except on 3/8" diameter and smaller



See Pages 59–60 for machining options.



## Inch Shaft Part • Numbering Chart



Configure Online

### Special

**CM** - Custom Machine

**SL** - Specified Length

### Shaft Length

**Inch** - 000.000

### Shaft Material

**No Entry** - 1060 CS

**SS** - 440 SS

**SS420** - 420 SS

**SS316** - 316 SS\* \*\*

**CP** - Chrome plate\*\*

**AR** - Armoloy\*\*

\* 300 Series available in most diameters

\*\*Available as special quotes

Class		Diameter	
Code	Description	Code	Desc.
NIL	Inch Class L Shaft (Steel)	03	3/16"
NIPDL	Inch Class L Predrill (Steel)	04	1/4"
CC	Feather Inch (Aluminum)	06	3/8"
CCPDL	Feather Inch Predrill (Aluminum)	08	1/2"
SR	Inch Support Rail (Aluminum)	10	5/8"
SRA	Inch Support Rail Assembly (Aluminum)	12	3/4"
CCR	Feather Rail Assembly (Aluminum)	16	1"
LSRA	Inch Low Support Rail Assembly (Steel)	20	1 1/4"
LSR	Inch Low Support Rail (Steel)	24	1 1/2"
LSG	Inch Low Support Rail Assembly (Steel)	32	2"
NIS	Inch Class S Shaft (Steel)	40	2 1/2"
NIN	Inch Class N Shaft (Steel)	48	3"
		64	4"

### Sample Part Numbers

Feather inch, 1" diameter and 15" long  
**CC16-015.000-SL**

Support rail assembly 1.5" diameter  
440 stainless steel and 12" long  
**SRA24SS-012.000-SL**

**Note:** Chrome will have a guaranteed thickness of 0.0001" to 0.0005".

Chrome thickness will be in addition to the catalog diameter of the shaft.

# Round Shafting Steel & Stainless Steel



## Simplicity RC60 Steel Solid Shafting NI

RC 60 Plus case hardened steel shafting  
 Optimized for Simplicity bearings and linear ball bearings  
 Available cut-to-length or full lengths



Length tolerance:  
 3/16" - 1-1/4" shaft = +/- 0.030"  
 1-3/8" - 2" shaft = +/- 0.060"  
 2-1/2" - 4" shaft = +/- 0.125"

Part No.	Nominal Dia. in.	Dia. Tolerance Class L* in.		Dia. Tolerance Class S* in.		Dia. Tolerance Class N* in.		Max Length in.	Min Hardness Depth in.	Weight Per In. lb.
		MIN	MAX**	MIN	MAX**	MIN	MAX*			
NI* 03-xxx.xxx	3/16"	0.1865	0.1870	-	-	-	-	252	0.027	0.008
NI* 04-xxx.xxx	1/4"	0.2490	0.2495	0.2485***	0.2490***	0.2498***	0.2500***	252	0.027	0.014
NI* 06-xxx.xxx	3/8"	0.3740	0.3745	0.3735***	0.3740***	0.3748***	0.3750***	252	0.027	0.031
NI* 08-xxx.xxx	1/2"	0.4990	0.4995	0.4985	0.4990	0.4998	0.5000	180	0.040	0.055
NI* 10-xxx.xxx	5/8"	0.6240	0.6245	0.6235	0.6240	0.6248	0.6250	180	0.040	0.086
NI* 12-xxx.xxx	3/4"	0.7490	0.7495	0.7485	0.7490	0.7498	0.7500	180	0.060	0.125
NI* 14-xxx.xxx	7/8"	0.8740	0.8745	-	-	0.8748	0.8750	180	0.060	0.170
NI* 16-xxx.xxx	1"	0.9990	0.9995	0.9985	0.9990	0.9998	1.0000	180	0.080	0.222
NI* 18-xxx.xxx	1-1/8"	1.1240	1.1245	-	-	1.1248	1.1250	180	0.080	0.281
NI* 20-xxx.xxx	1-1/4"	1.2490	1.2495	1.2485	1.2490	1.2498	1.2500	180	0.080	0.348
NI* 22-xxx.xxx	1-3/8"	1.3740	1.3745	-	-	1.3747	1.3750	180	0.080	0.420
NI* 24-xxx.xxx	1-1/2"	1.4989	1.4994	1.4984	1.4989	1.4997	1.5000	180	0.080	0.500
NI* 28-xxx.xxx	1-3/4"	1.7490	1.7495	-	-	1.7497	1.7500	180	0.100	0.681
NI* 32-xxx.xxx	2"	1.9987	1.9994	1.9980	1.9987	1.9997	2.0000	180	0.100	0.890
NI* 40-xxx.xxx	2-1/2"	2.4985	2.4993	2.4977	2.4985	2.4996	2.5000	180	0.100	1.391
NI* 48-xxx.xxx	3"	2.9983	2.9992	2.9974	2.9983	2.9996	3.0000	180	0.100	2.003
NI* 64-xxx.xxx	4"	3.9976	3.9988	-	-	-	-	140	0.100	3.560

\*Third letter of Part No. reflects the shaft class (NIL for Class L, NIS for Class S, and NIN for Class N).

\*\*MAX length subject to change.

\*\*\*1/4" and 3/8" shafting are available in class S and N for volume requests only.

Notes: (1) Specify length in part number using inches.

(2) Example: for 1/2" class T shafting total length 15" = NIL08-015.000

(3) Surface finish bearing recommended 8-10 Ra.

## 440 & 420 Stainless Steel Solid Shafting NI\_SS & NI\_SS420

Part No.		Nominal Dia. in.	Dia. Tolerance Class L in.		Dia. Tolerance Class S* in.		Max Length in.	Min Hardness Depth in.	Weight Per In. lb.
440 SS	420 SS		MIN	MAX	MIN	MAX**			
NI* 03SS-xxx.xxx	NI* 03SS420-xxx.xxx	3/16"	0.1865	0.1870	N/A	N/A	252	0.027	0.008
NI* 04SS-xxx.xxx	NI* 04SS420-xxx.xxx	1/4"	0.2490	0.2495	0.2485***	0.2490***	252	0.027	0.014
NI* 06SS-xxx.xxx	NI* 06SS420-xxx.xxx	3/8"	0.3740	0.3745	0.3735***	0.3740***	252	0.027	0.031
NI* 08SS-xxx.xxx	NI* 08SS420-xxx.xxx	1/2"	0.4990	0.4995	0.4985	0.4990	154	0.040	0.055
NI* 10SS-xxx.xxx	NI* 10SS420-xxx.xxx	5/8"	0.6240	0.6245	0.6235	0.6240	154	0.040	0.087
NI* 12SS-xxx.xxx	NI* 12SS420-xxx.xxx	3/4"	0.7490	0.7495	0.7485	0.7490	154	0.060	0.125
NI* 16SS-xxx.xxx	NI* 16SS420-xxx.xxx	1"	0.9990	0.9995	0.9985	0.9990	176	0.080	0.222
NI* 20SS-xxx.xxx	NI* 20SS420-xxx.xxx	1-1/4"	1.2490	1.2495	1.2485	1.2490	154	0.080	0.348
NI* 24SS-xxx.xxx	NI* 24SS420-xxx.xxx	1-1/2"	1.4989	1.4994	1.4984	1.4989	154	0.080	0.498
NI* 32SS-xxx.xxx	NI* 32SS420-xxx.xxx	2"	1.9987	1.9994	1.9980	1.9987	154	0.100	0.886

\*Third letter of Part No. reflects the shaft class (NIL for Class L, NIS for Class S, and NIN for Class N).

\*\*MAX length subject to change.

\*\*\*1/4" and 3/4" shafting are available in class S for volume requests only.

440 & 420 stainless steel RC 50 Plus™ hardness

Optimized for Simplicity bearings and linear ball bearings

Available cut-to-length or random lengths

Length tolerance:

3/16" - 1-1/4" shaft = +/- 0.030"

1-3/8" - 2" shaft = +/- 0.060"

2-1/2" - 4" shaft = +/- 0.125"



Email an Application Engineer

INCH

ISO METRIC

JIS METRIC

## Pre-Drilled & Tapped

Steel NIPDL • 440 Stainless Steel NIPDLxxSS • 420 Stainless Steel NIPDLxxSS420 • 316 Stainless Steel NIPDLxxSS316

Part No.				Nominal Dia. in.	Dia. Tolerance Class L in.		Standard Hole Spacing		Thread	Max Length in.	Weight Per Inch lb.
Steel	440 SS	420 SS	316 SS		MIN	MAX	X	Y			
NIPDL08	NIPDL08SS	NIPDL08SS420	NIPDL08SS316	1/2"	0.4990	0.4995	4	2	6-32	144	0.055
NIPDL10	NIPDL10SS	NIPDL10SS420	NIPDL10SS316	5/8"	0.6240	0.6245	4	2	8-32	144	0.086
NIPDL12	NIPDL12SS	NIPDL12SS420	NIPDL12SS316	3/4"	0.7490	0.7495	6	3	10-32	144	0.125
NIPDL16	NIPDL16SS	NIPDL16SS420	NIPDL16SS316	1"	0.9990	0.9995	6	3	1/4-20	144	0.222
NIPDL20	NIPDL20SS	NIPDL20SS420	NIPDL20SS316	1-1/4"	1.2490	1.2495	6	3	5/16-18	144	0.348
NIPDL24	NIPDL24SS	NIPDL24SS420	NIPDL24SS316	1-1/2"	1.4989	1.4994	8	4	3/8-16	132	0.500
NIPDL32	NIPDL32SS	NIPDL32SS420	NIPDL32SS316	2"	1.9987	1.9994	8	4	1/2-13	132	0.890
NIPDL48	*	*	*	3"	2.9983	2.9992	8	4	3/4-10	132	2.003

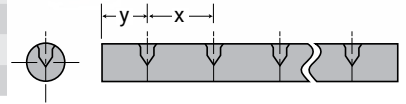

Part Numbers are complete when Length and Type are added.

**Example:** Complete Part Number for a 1 inch diameter 440 Stainless Steel shaft of 24 inches = NIPDL16SS-024.000-SL

\*Special orders available on this option.

- Notes:** (1) Specify length in part number using inches. **Example:** 1/2" shafting at a length of 15" = NIPDL08-015.000  
 (3) Customer specifies 'y' dimension, if different than standard. Hole-to-hole tolerance = +/-0.015".  
 (4) Consult factory for chrome plated or 303 stainless steel shafting.

## Ceramic Coated

- Aluminum alloy base material
- Optimized for FrelonGOLD® liners
- Interchanges with solid and pre-drilled shafting
- Non-magnetic and vibration resistant
- Weld splatter, paints, and contaminants will not stick
- Ceramic-like coating provides hardness up to RC70 and increased corrosion resistance
- NOT to be used with linear ball bearings (*Does not apply to linear guide products – MR, UG, UGA, etc*)
- NOT compatible with linear ball bearings or roller pillow block assemblies

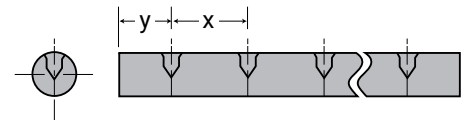

Length tolerance: 3/16" – 1-1/4" shaft = +/- 0.030"  
 1-3/8" – 2" shaft = +/- 0.060"  
 2-1/2" – 4" shaft = +/- 0.125"

## Solid Shafting CC

Part No.	Nominal Dia. in.	Diameter Tolerance		MAX Length in.	Weight lb./in.
		MIN	MAX		
CC03-xxx.xxx	3/16"	0.1863	0.1871	138	0.003
CC04-xxx.xxx	1/4"	0.2488	0.2496	138	0.005
CC06-xxx.xxx	3/8"	0.3738	0.3746	138	0.010
CC08-xxx.xxx	1/2"	0.4988	0.4996	138	0.019
CC10-xxx.xxx	5/8"	0.6238	0.6246	138	0.030
CC12-xxx.xxx	3/4"	0.7488	0.7496	138	0.043
CC16-xxx.xxx	1"	0.9988	0.9996	138	0.077
CC20-xxx.xxx	1-1/4"	1.2488	1.2496	138	0.120
CC24-xxx.xxx	1-1/2"	1.4987	1.4995	138	0.173
CC32-xxx.xxx	2"	1.9985	1.9995	138	0.308

- Notes:** (1) Specify length in part number using inches.  
**Example:** 1/2" shafting total length 36" long = CC08-036.000.  
 (2) Ends of cut-to-length shafting are not coated.  
 (3) Fully coated shafting is available on special request.

## Pre-Drilled & Tapped CCPDL

Part No.	Nominal Dia. in.	Diameter Tolerance		Standard Hole Spacing		Thread	MAX Length in.	Weight lb./in.
		MIN	MAX	X	Y			
CCPDL08-xxx.xxx	1/2"	0.4988	0.4996	4	2	6-32	138	0.019
CCPDL10-xxx.xxx	5/8"	0.6238	0.6246	4	2	8-32	138	0.030
CCPDL12-xxx.xxx	3/4"	0.7488	0.7496	6	3	10-32	138	0.043
CCPDL16-xxx.xxx	1"	0.9988	0.9996	6	3	1/4-20	138	0.077
CCPDL20-xxx.xxx	1-1/4"	1.2488	1.2496	6	3	5/16-18	138	0.120
CCPDL24-xxx.xxx	1-1/2"	1.4987	1.4995	8	4	3/8-16	138	0.173
CCPDL32-xxx.xxx	2"	1.9985	1.9995	8	4	1/2-13	138	0.308

- Notes:** (1) Specify length in part number using inches.  
**Example:** 1/2" shafting total length 36" long = CCPDL08-036.000.  
 (2) Ends of cut-to-length shafting are not coated.  
 (3) Fully coated shafting is available on special request.  
 (4) Counterbore 0.063" from top.  
 (5) Customer specifies 'y' dimension, if different than standard.

# Shafting End Support Blocks

## Aluminum End Support Block NSB

End support blocks can be used for end or intermittent shaft support. The aluminum end support block is lightweight and strong, and can be used with all shaft types. Ideally, they should be used where deflection between supports is not a problem.

Available in inch sizes from 1/4" - 2"

Instant bolt-down installation

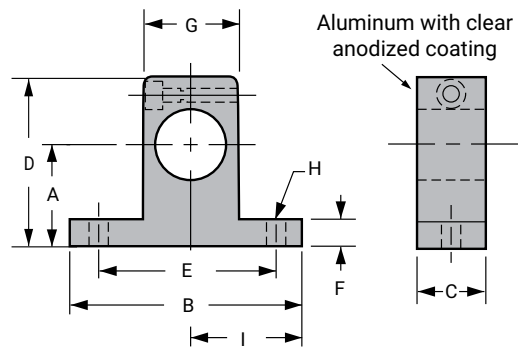

Part No.	Nominal Dia. in.	A +/- 0.001	B	C	D	E +/- 0.001	F	G	H		I +/- 0.001	Weight lb.
									Bolt	Hole		
NSB04	1/4"	0.687	1.500	0.500	1.050	1.125	0.250	0.500	#6	5/32"	0.750	0.038
NSB06	3/8"	0.750	1.625	0.563	1.175	1.250	0.250	0.688	#6	5/32"	0.800	0.044
NSB08	1/2"	1.000	2.000	0.625	1.625	1.500	0.250	0.875	#8	3/16"	1.000	0.079
NSB10	5/8"	1.000	2.500	0.688	1.750	1.875	0.313	1.000	#10	7/32"	1.250	0.112
NSB12	3/4"	1.250	2.500	0.750	2.055	2.000	0.313	1.250	#10	7/32"	1.375	0.148
NSB16	1"	1.500	3.055	1.000	2.500	2.500	0.375	1.500	1/4"	9/32"	1.625	0.313
NSB20	1-1/4"	1.750	3.750	1.125	3.000	3.000	0.438	2.000	5/16"	11/32"	2.000	0.527
NSB24	1-1/2"	2.000	4.375	1.250	3.500	3.500	0.500	2.250	5/16"	11/32"	2.375	0.755
NSB32	2"	2.500	5.500	1.500	4.375	4.500	0.625	3.000	3/8"	13/32"	3.000	1.464

## Steel End Support Block LSB

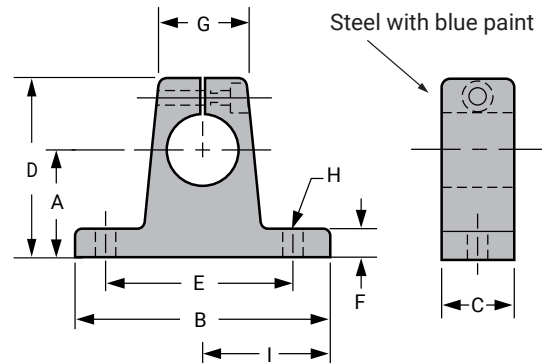

Part No.	Retired Part No.	Nom. Shaft Diameter	A ±0.002	B	C	D	E ±0.005	F	G	H		I +/- 0.001	Weight lb.
										Bolt	Hole		
LSB08	SB-8	1/2	1.000	2.000	0.625	1.625	1.500	0.250	0.750	#10	7/32	1.000	0.270
LSB10	SB-10	5/8	1.000	2.500	0.750	1.750	1.875	0.312	0.875	#10	7/32	1.250	0.400
LSB12	SB-12	3/4	1.250	2.750	0.750	2.125	2.000	0.375	1.000	1/4	9/32	1.375	0.520
LSB16	SB-16	1	1.500	3.312	1.000	2.625	2.500	0.375	1.375	1/4	9/32	1.656	1.110
LSB20	SB-20	1-1/4	1.750	4.000	1.250	3.000	3.000	0.437	1.750	5/16	11/32	2.000	1.910
LSB24	SB-24	1-1/2	2.000	4.750	1.250	3.500	3.500	0.500	2.000	5/16	11/32	2.375	2.520
LSB32	SB-32	2	2.500	6.000	1.500	4.500	5.000	0.625	2.625	3/8	13/32	3.000	5.100
LSB32-4.500	-	2	2.500	6.000	1.500	4.500	4.500	0.625	2.625	3/8	13/32	3.000	5.100

## Rail Assembly – Aluminum Support Rail SRA

Two piece assembly RC60 steel shaft and aluminum support rail standard

Other shaft materials – 440, 420, 316 stainless steel, and ceramic coated aluminum

No coating



Available cut-to-length, tolerance:

3/16" – 1-1/4" shaft = +/- 0.030"

1-3/8" – 2" shaft = +/- 0.060"

2-1/2" – 4" shaft = +/- 0.125"

Shaft Size	Part No.		Nominal Dia. in.	Diameter Tolerance		A +/-0.002	B	C	D	E	F		Standard Hole Spacing		Weight lb./in.
	Material**	Length		MIN	MAX						Bolt	Hole	X	Y	
SRA08	_____	-----SL	1/2	0.4988	0.4996	1.125	1.500	0.250	0.188	1.000	#6	0.169	4	2	0.101
SRA10	_____	-----SL	5/8	0.6238	0.6246	1.125	1.625	0.313	0.250	1.125	#8	0.193	4	2	0.145
SRA12	_____	-----SL	3/4	0.7488	0.7496	1.500	1.750	0.375	0.250	1.250	#10	0.221	6	3	0.202
SRA16	_____	-----SL	1	0.9988	0.9996	1.750	2.125	0.500	0.250	1.500	1/4"	0.281	6	3	0.328
SRA20	_____	-----SL	1-1/4	1.2488	1.2496	2.125	2.500	0.563	0.313	1.875	5/16"	0.343	6	3	0.493
SRA24	_____	-----SL	1-1/2	1.4987	1.4995	2.500	3.000	0.688	0.375	2.250	5/16"	0.343	8	4	0.711
SRA32	_____	-----SL	2	1.9985	1.9995	3.250	3.750	0.875	0.500	2.750	3/8"	0.406	8	4	1.231
SRA48	_____	-----SL	3	2.9983	2.9992	4.000	6.000	1.400	0.750	4.250	3/4"	0.630	8	4	2.641

Part Numbers are complete when **Material** and **Length** are added.  
Default material is 1060 steel when no Material is specified.

\*\*For other steel options add below code into **Material** location:

- CC** Ceramic Coated Shafting
- SS** 440 Stainless Steel
- SS420** 420 Stainless Steel
- SS316** 316 Stainless Steel

**Example 1:** The Complete Part Number for a 1 inch diameter 440 Stainless Steel shaft of 24 inches is SRA16**SS-024.000**-SL

**Example 2:** The Complete Part Number for a 3/4 inch diameter 1060 Steel shaft of 18 inches is SRA12-**018.000**-SL

**Note:** Specify length in part number using inches.

**Example:** for 1/2" shafting total length 36" long = SRA08-036.000.

Customer specifies 'y' dimension, if different than standard.

**Contact PBC Linear for other available hole patterns.**

\* For diameter tolerances on Ceramic Coated Shafting, see tables on page 54

# Shafting Rail Assemblies

## Support Rail – Aluminum SR & SR\_PD

### Non-Drilled (SR)

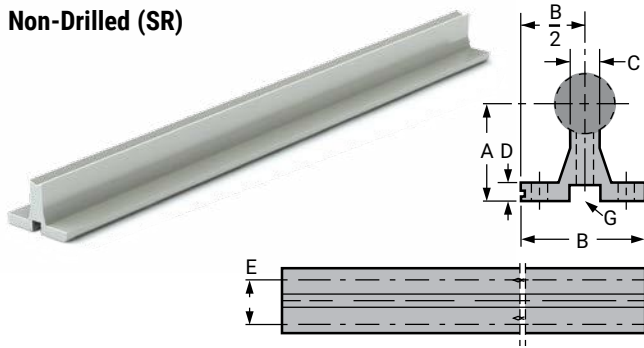

### Pre-Drilled (SRxxPD)

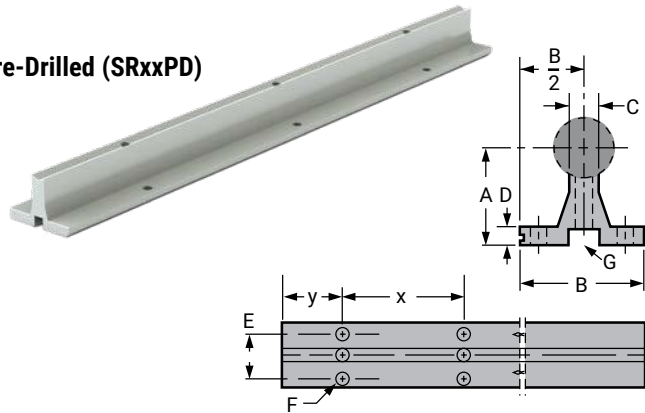

Part No.		Nominal Dia.	A	B	C	D	E	Standard Hole Spacing		G Recommended Mounting Hole Size			MAX Length	Weight
Non-Drilled	Pre-Drilled	In.	+/-0.002					X	Y	Hole	Screw	Fastener Length	+0/-0.125	lb./in.
SR08-xxx.xxx	SR08PD-xxx.xxx	1/2"	1.125	1.500	0.250	0.188	1.000	4	2	0.169	6-32 x 7/8"	7/8"	48	0.045
SR10-xxx.xxx	SR10PD-xxx.xxx	5/8"	1.125	1.625	0.313	0.250	1.125	4	2	0.193	8-32 x 7/8"	7/8"	48	0.058
SR12-xxx.xxx	SR12PD-xxx.xxx	3/4"	1.500	1.750	0.375	0.250	1.250	6	3	0.221	10-32 x 7/8"	7/8"	48	0.077
SR16-xxx.xxx	SR16PD-xxx.xxx	1"	1.750	2.125	0.500	0.250	1.500	6	3	0.281	1/4-20 x 1-1/2"	1-1/2"	48	0.104
SR20-xxx.xxx	SR20PD-xxx.xxx	1-1/4"	2.125	2.500	0.563	0.313	1.875	6	3	0.343	5/16-18 x 1-3/4"	1-3/4"	48	0.145
SR24-xxx.xxx	SR24PD-xxx.xxx	1-1/2"	2.500	3.000	0.688	0.375	2.250	8	4	0.406	3/8-16 x 2"	2"	48	0.210
SR32-xxx.xxx	SR32PD-xxx.xxx	2"	3.250	3.750	0.875	0.500	2.750	8	4	0.531	1/2-13 x 2-1/2"	2-1/2"	48	0.342
SR48-xxx.xxx	SR48PD-xxx.xxx	3"	4.000	6.000	1.400	0.750	4.250	8	4	0.625	3/4-10 x 3-1/4"	3"	48	0.638

- Notes:** (1) Specify length in part number. **Example:** 1/2" shafting support rail to 24" length = SR08-024.000 (Aluminum alloy construction, no coating).  
 (2) Shafts and support rails sold separately. Customer specifies 'y' dimension. Shaft rails and assemblies are available in long lengths, consult factory.  
 (3) **Contact PBC Linear for other available hole patterns.**

## Rail Assembly – Ceramic Coated CCR

Ceramic-like coating provides hardness up to RC70 and increased corrosion resistance

Optimized for FrelonGOLD® liners

NOT to be used with linear ball bearings

(Does not apply to linear guide products – MR, UG, UGA, etc)

Economical, lightweight alternative to traditional steel shafting

One-piece integrated design eliminates assembly time

Weld splatter, paints, and contaminants will not stick

Non-magnetic and vibration resistant

Pre-drilled with stand X hole spacing\*

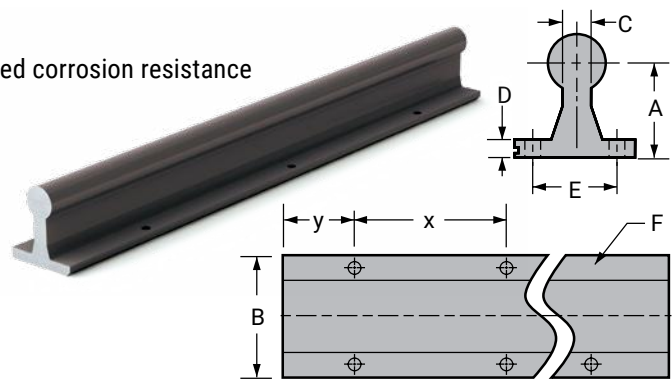

Part No.	Nominal Dia.	Diameter Tolerance		A	B	C	D	E	F		Standard Hole Spacing		MAX Length	Weight
		MIN	MAX						Bolt	Hole	X	Y		
CCR08-xxx.xxx	1/2	0.4988	0.4996	1.125	1.500	0.250	0.188	1.000	#6	0.169	4	2	120	0.019
CCR10-xxx.xxx	5/8	0.6238	0.6246	1.125	1.625	0.313	0.250	1.125	#8	0.193	4	2	120	0.030
CCR12-xxx.xxx	3/4	0.7488	0.7496	1.500	1.750	0.375	0.250	1.250	#10	0.221	6	3	120	0.043
CCR16-xxx.xxx	1	0.9988	0.9996	1.750	2.125	0.500	0.250	1.500	1/4"	0.281	6	3	120	0.076
CCR20-xxx.xxx	1-1/4	1.2488	1.2496	2.125	2.500	0.563	0.313	1.875	5/16"	0.343	6	3	120	0.119
CCR24-xxx.xxx	1-1/2	1.4987	1.4995	2.500	3.000	0.688	0.375	2.250	5/16"	0.343	8	4	120	0.172
CCR32-xxx.xxx	2	1.9985	1.9995	3.250	3.750	0.875	0.500	2.750	3/8"	0.406	8	4	120	0.305

- Notes:** (1) Specify length in part number using inches.  
**Example:** 1/2" shafting total length 36" long = CCR08-036.000.  
 (2) Cut-to-length rails may not be coated on the ends.  
 (3) **Contact PBC Linear for other available hole patterns.**

**DO NOT** use with linear ball bearings or roller pillow block assemblies.  
 \*Customer specified 'Y' dimension.

INCH

ISO METRIC

JIS METRIC

## Low Support Rail – Steel LSR

The AISI C-1018 steel LSR shaft support is a low support rail with a reduced footprint, and 40% lower profile than other support rails. This is an excellent choice for applications requiring compact low shaft support. The standard length for LSR type supports is 48".

No coating

Length tolerance +0", -1/8".

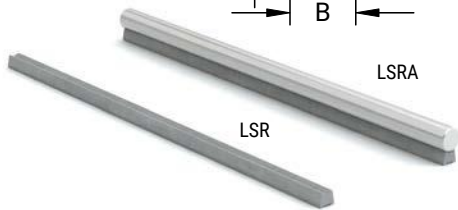
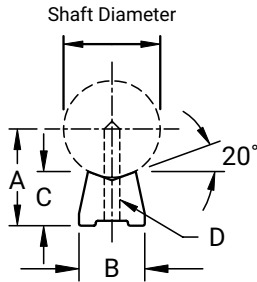

Part No.	Assembly Part No.	Shaft Dia. in.	A +/-0.002	B +/-0.005	C (Ref)	D		Hole Spacing For LSR-Pd Pre-Drilled		Weight Per 48" (Approximate) lb. +/-0.001	Assembly Weight Per 48" (Approximate) lb. +/-0.001
						Bolt	Hole	Y	X		
LSR-8 LSR-8-PD	LSRA-8	1/2	0.562	0.370	0.341	6-32	0.169	2	4	1.320	3.960
LSR-10 LSR-10-PD	LSRA-10	5/8	0.687	0.450	0.412	8-32	0.193	2	4	1.950	6.078
LSR-12 LSR-12-PD	LSRA-12	3/4	0.750	0.510	0.420	10-32	0.221	3	6	2.250	8.250
LSR-16 LSR-16-PD	LSRA-16	1	1.000	0.690	0.560	1/4-20	0.281	3	6	4.250	14.910
LSR-20 LSR-20-PD	LSRA-20	1-1/4	1.187	0.780	0.626	5/16-18	0.343	3	6	5.080	21.780
LSR-24 LSR-24-PD	LSRA-24	1-1/2	1.375	0.930	0.703	3/8-16	0.406	4	8	6.720	30.720
LSR-32 LSR-32-PD	LSRA-32	2	1.750	1.180	0.845	1/2-13	0.531	4	8	11.000	53.720
LSR-48 LSR-48-PD	LSRA-48	3	2.750	1.875	1.404	3/4-10	0.812	4	8	27.920	124.060

### How to order

- Available as cut to length options up to a max length of 144".  
**Example:** 48" would be LSR12-048.000-SL
- If standard mounting holes are required, specify low shaft rails with pre-drilled mounting holes by part number. For example, LSR-12-PD. Hole sizes and spacings are shown in the table.
- If other than standard hole spacing is required, please provide drawings with all dimensions, tolerances, and quantity. With or without mounting holes, low shaft rails will be supplied in 48" lengths when ordered by part number.

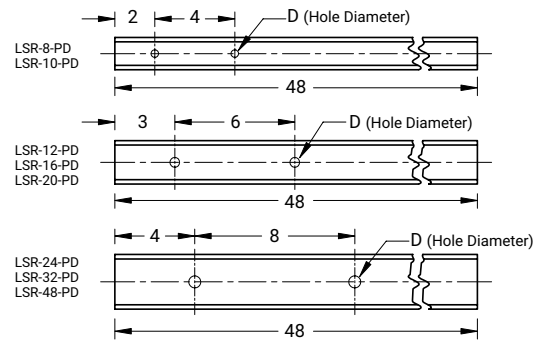

## Low Support Rail & Shaft Set LSG

Precision case hardened and ground shaft, plus an LSR steel support rail, effectively doubles the life of the shaft by allowing it to be turned over for a fresh surface when wear becomes evident. Both sides of the shaft are counterbored so the shaft may be rotated 180°, and rebolted for use on the new side. This guide is sold as a two-piece set; the shaft and support are not assembled. The guide is then bolted down through the top of the shaft to reduce installation time. The shafts are also available in 400 series stainless steel. Drilled through and counterbored shafts may not be suitable for all linear bearings.

No coating



Part No.	Shaft Dia. in.	H in.	B in.	Y in.	X in.	N in.	Weight Per in. lb.
LSG-10	5/8	0.687	0.450	2	4	#5	0.132
LSG-12	3/4	0.750	0.510	3	6	#6	0.171
LSG-16	1	1.000	0.690	3	6	#10	0.311
LSG-20	1-1/4	1.187	0.780	3	6	5/16	0.454
LSG-24	1-1/2	1.375	0.930	4	8	3/8	0.640
LSG-32	2	1.750	1.180	4	8	1/2	1.119

**Note:** Customer specifies 'y' dimension.

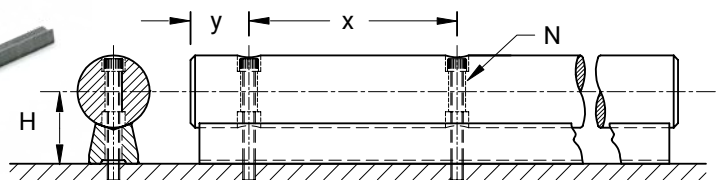

# Custom Machining Options for Shafts

Configure Now



## Special Machining

Standard 60 Plus shafting, which is available from stock, can be cut with special length tolerances. 60 Plus shafting may also be drilled with a variety of radial holes and tapped if needed. Shafts can be supplied with flats, keyways, and reduced diameters. Shafts can also be plated.

There is an extra charge for all special machining operations. For specific prices, send your drawing or technical description to PBC Linear.

## Special Length Tolerances

Standard length tolerances for shafting are:

< 1 1/4" diameter	$\pm 1/32"$ ( $\pm 0.03"$ )
1 3/8"-2" diameter	$\pm 1/16"$ ( $\pm 0.06"$ )
> 2" diameter	$\pm 1/8"$ ( $\pm 0.125"$ )

All SR, LSR, SRA, LSRA, and CCR are  $+0.000"/-0.125"$ . Contact us with special requirements.

## Special Straightness Tolerances

PBC Linear standard length tolerances are 0.001 to 0.002"/ft cumulative. Except for 3/8" diameters and less. Contact us with special requirements.

## Standard Chamfers

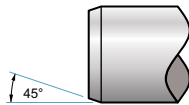

Diameter	Size	Tolerance
$\leq 3/8"$	Break Edge	$\pm 0.005-0.010" \times 45^\circ$
10 mm-7/8"	1/32" x 45°	$\pm 0.005"$
1"-2"	1/16" x 45°	$\pm 0.010"$
2 1/2"-3"	1/8" x 45°	$\pm 0.010"$

Special chamfer at any angle can be supplied for an additional charge.

## Machining Shaft Ends

Certain complex machined ends may require annealing. Consult the factory on whether annealing is needed for your custom machined end. Customer must specify if they want to forego the annealing for their custom machined end.

Contact the factory for special options.

## Radial Holes Drilled and Tapped to Center of Shaft

U.N.C. or U.N.F.  
Class 2-B thread.

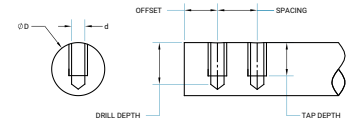

Hole to Hole	$\pm 0.010"$ Non-Accum
Hole to Centerline	$\pm 0.0075"$
Hole to End	$\pm 0.030"$ ( $\pm 0.06$ mm)

Note: Hole depth full threads to 1/2" of the shaft diameter.

## Radial Holes Drilled and Tapped through Shaft

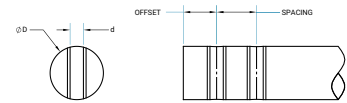

## Radial Holes Drilled through Shaft

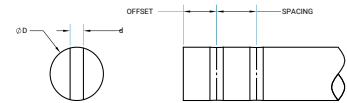

Hole Diameter	$\pm 0.005"$
Hole to Hole	$\pm 0.010"$ Non-Accum
Hole to Centerline	$\pm 0.0075"$
Hole to End	$\pm 0.030"$

## Radial Holes Drilled and Reamed through Shafts

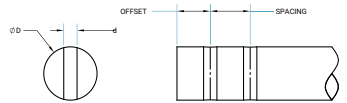

Hole Diameter	$\pm 0.001"$
Hole to Hole	$\pm 0.010"$ Non-Accum
Hole to Centerline	$\pm 0.0075"$
Hole to End	$\pm 0.030"$

## Threaded Shaft Diameter

Standard threads are either Unified National Coarse or Unified National Fine, Class 2-A fit. Shafts will be annealed and soft around the circumference of threaded areas within the case

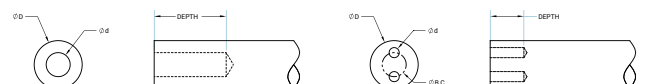

Standard Threads	UNC or UNF Class 2-A
------------------	----------------------

Note: Threading area will be annealed and soft.

INCH

ISO METRIC

JIS METRIC

### Reduced Shaft Diameter

Standard diameter tolerances on turned down diameters are  $\pm 0.001"$ . Special tolerances of  $\pm 0.0001"$  are available. Runout is within  $0.001"$  total indicator reading. Two-step shaft diameter reduction is also available.

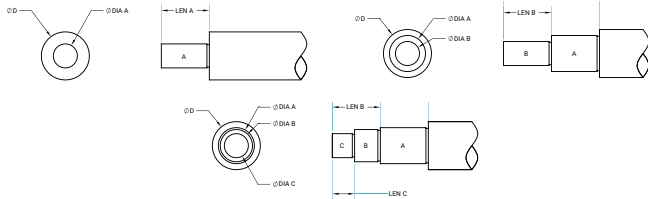

Normal Tolerance	$\pm 0.001"$
Concentricity	$\pm 0.002"$ MAX T.I.R.

### Coaxial Holes Drilled and Tapped in Center of End of Shaft

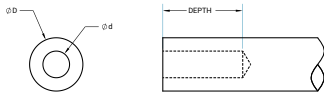

Concentricity	0.01"
Diameter of Holes	$\pm 0.006"$
Bored Holes	$\pm 0.001"$
Bolt Circles	$\pm 2^\circ$
Coaxial on Both Ends	OAL $\pm 0.015"$
Axial on One End	OAL $\pm 0.030"$

Note: Depth is twice the diameter of the tap minimum.

### Dowel Joints

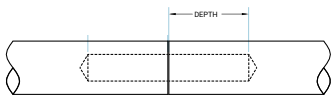

Match over joint of 0.002 Maximum TIR

All Linear Dimensions	$\pm 0.010"$
First Hole	$\pm 0.0075"$
Shaft Diameter	5/8" to 3"

Note: Ends machined square without chamfer.

### Retaining Ring Groove

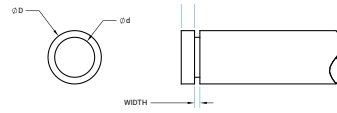

Location Tolerance	$\pm 0.062"$ Standard
	$\pm 0.005"$ Custom

### Butted Joints

Ends machined square, no chamfer. Available for all nominal shaft diameters.

Perpendicularity	$\pm 0.001"$ MAX
All Linear Dimensions	$\pm 0.010"$

Note: Ends machined square without chamfer.

### Flat(s) on Shaft

Flats are available. Flats extending over large portion of shaft or entire length of shaft are not available. Cutting into hardened layer would cause considerable warping and subsequent straightening costs would be prohibitive.

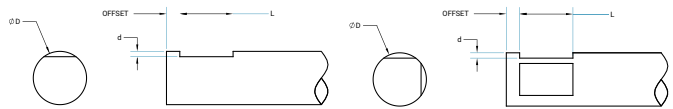

Location Tolerance	$\pm 0.010"$
--------------------	--------------

Note: Bottom corners of flat will have a  $0.030"$  radius due to manufacturing process.

### Keyways

Keyways may be square, flat or American Standard Woodruff. Available for nominal shaft diameters from 1/2" through 4".



Other options available. Contact us for a quote.

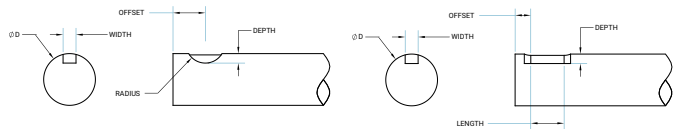

Width	$\pm 0.001"$
Length	$\pm 0.010"$
Linear Locations	$\pm 0.010"$
Location to C/L	$\pm 0.0075"$
Depth	1/2" width + "M" on table 8

Note: Square or American Standard Woodruff. Maximum length in house is 48".

# Simplicity® Square Bearings and Shafting

INCH

ISO METRIC

JIS METRIC

## Product Overview

- Runs on a single, square shaft eliminating costly components
- Maintains radial integrity and can eliminate the need for parallel shafting
- Can be mounted in any orientation
- Housings are aluminum alloy with a standard anodized finish
- Utilizes standard bearing plugs
- Adjustable to maintain tight running clearances, contingent upon shafting
- Bearing plugs are easily replaced

## Same characteristics of the standard round-way Simplicity bearings:

- Self-lubricating
- High load capacity
- Wide temperature range:  
(-400°F/+400°F)  
(-240°C/+204°C)
- Excel in contaminated environments
- High shock loading abilities
- Low wear rates



Frelon® Bearing Surface has Angled Slot

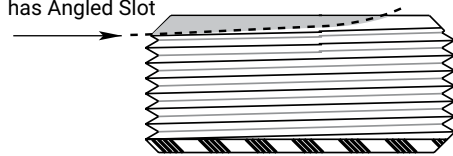

## Adjustable Bearing Plugs

**Bearing material:** Part number APN16E plug with Frelon® J is standard for PST stainless steel square shafting. Part number APN16 plug with FrelonGOLD® is also available for applications to be run on steel. Plug material is 316 stainless steel.

- Bearing plugs can be purchased separately
- Ideal for use in many applications as a wear pad
- Bearing surface area = 0.300 in<sup>2</sup>
- Max static load capacity per plug (Frelon J)= 450 lb.
- The use of green Loctite or similar is recommended to hold the adjustable bearing plugs in position while allowing relative ease of adjustment

Frelon® Bearing Surface (Approx. 0.025 thick)  
3/4 - 20  
CLASS #2 Thread

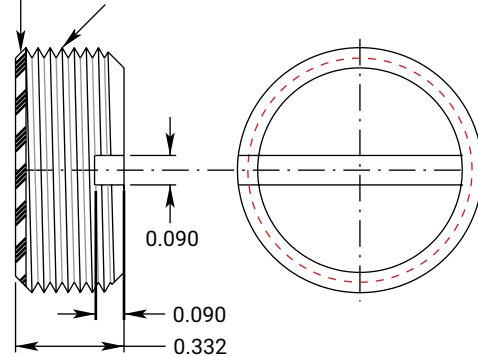

## ORDERING INFORMATION

Part No.	Description
APN16E	Standard: Adjustable bearing plug with Frelon J bearing liner. Use with 300 series stainless or soft shafting.
APN16	Optional: Adjustable bearing plug with FrelonGOLD bearing liner. Use with steel shafting.

FrelonGOLD  
APN16



Frelon J  
APN16E



# Simplicity® Square Shafting, Bearings & Plugs

## Square Bearing Cutaway View

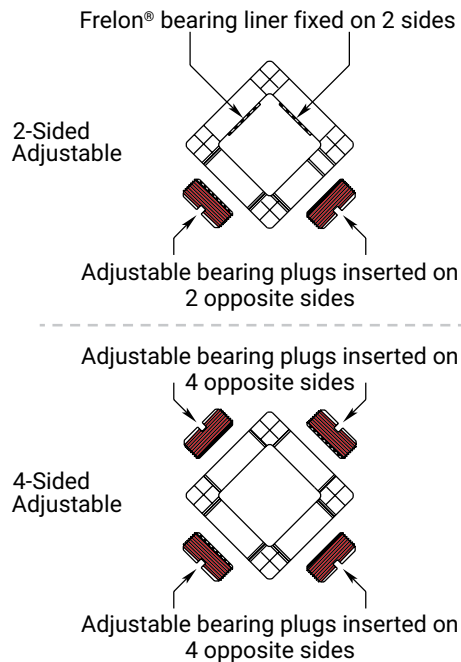
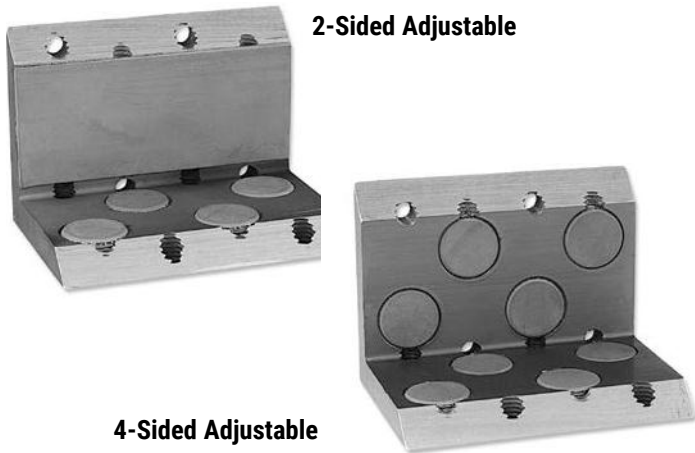

### APPLICATION NOTE

Use removable Loctite thread locker to hold the adjustable bearing plugs in position.

Two parameters must be met in the design and use of square bearings:

1. The 2:1 ratio for cantilevered loads applies to square bearings in the same way as roundway Simplicity® bearings. Binding will occur if the ratio is not met.

**Note:** If only one bearing is used, the 2:1 applies from plug centers.

2. The maximum load and moment load must be met. To calculate the acceptable cantilever or lever arm, multiply the length (from center of the bearing to the center of the load) times the weight. The result must be less than the moment load for that orientation.

**Example:** Distance of cantilever = 3"  
Amount of load = 40 lb.  
3" x 80 lb. = 240 in-lb.

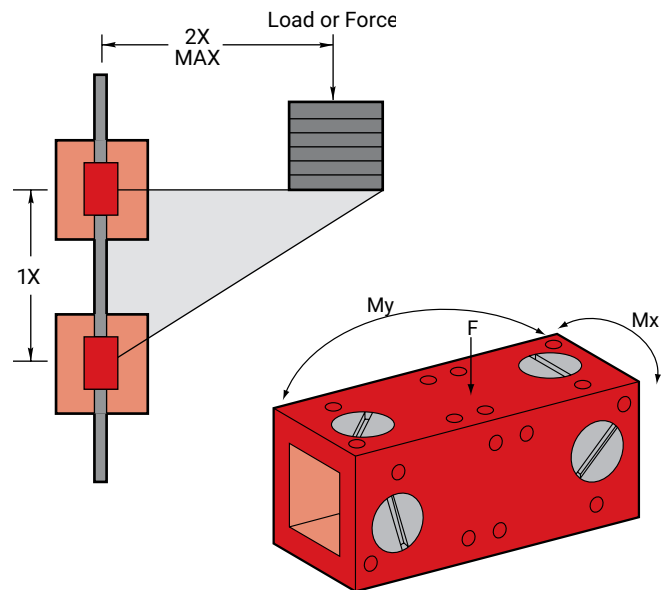

### SQUARE BEARING LOAD INFORMATION

Part No.	MAX Moments Torsional Capacities in.-lb.		Max Force lb. F
	Mx	My	
SB16	74	165	920
SBL16	74	475	920
SB24	416	402	1840
SBL24	416	1413	1840

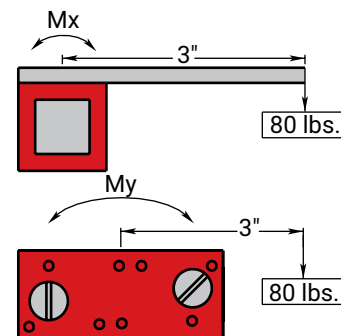

# Simplicity® Square Bearings • 1.0 Inch

## ORDERING INFORMATION

Part No.	Description	Bearing Weight lb.
SB16-2E	Standard 1.0" two-sided adjustable square bearing with Frelon® J plugs for stainless steel shafting.	0.48
SB16-2	Optional 1.0" two-sided adjustable square bearing with FrelonGOLD® plugs for steel shafting.	0.48
SB16-4E	Standard 1.0" four-sided adjustable square bearing with Frelon J plugs for stainless steel shafting.	0.56
SB16-4	Optional 1.0" four-sided adjustable square bearing with FrelonGOLD plugs for steel shafting.	0.56
SBL16-2E	Standard 1.0" extended length, two-sided adjustable square bearing with Frelon J plugs for stainless steel shafting.	0.77
SBL16-2	Optional 1.0" extended length, two-sided adjustable square bearing with FrelonGOLD plugs for steel shafting.	0.77
SBL16-4E	Standard 1.0" extended length, four-sided adjustable square bearing with Frelon J plugs for stainless steel shafting.	0.85
SBL16-4	Optional 1.0" extended length, four-sided adjustable square bearing with FrelonGOLD plugs for steel shafting.	0.85

**SB16-2** 1.0" 2-sided adjustable square bearing

**SB16-4** 1.0" 4-sided adjustable square bearing

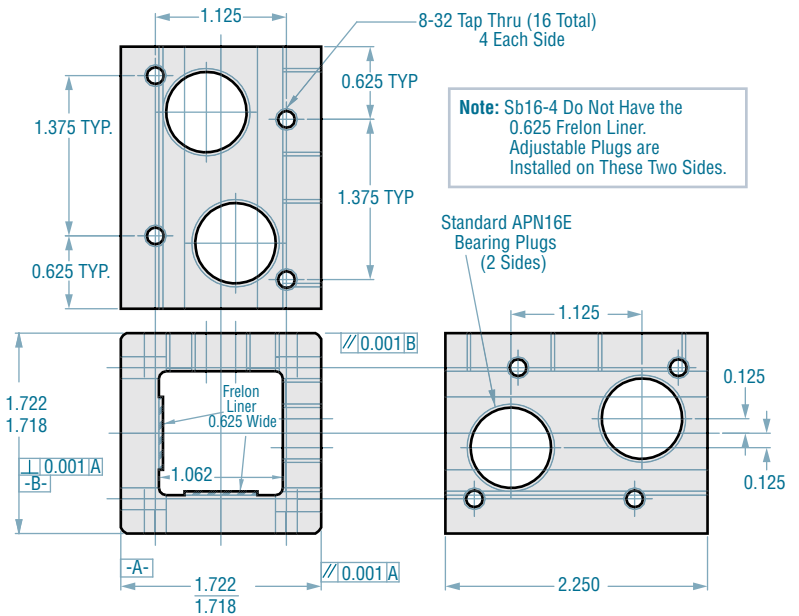

**SBL16-2** 1.0" Extended length 2-sided adjustable square bearing

**SBL16-4** 1.0" Extended length 4-sided adjustable square bearing

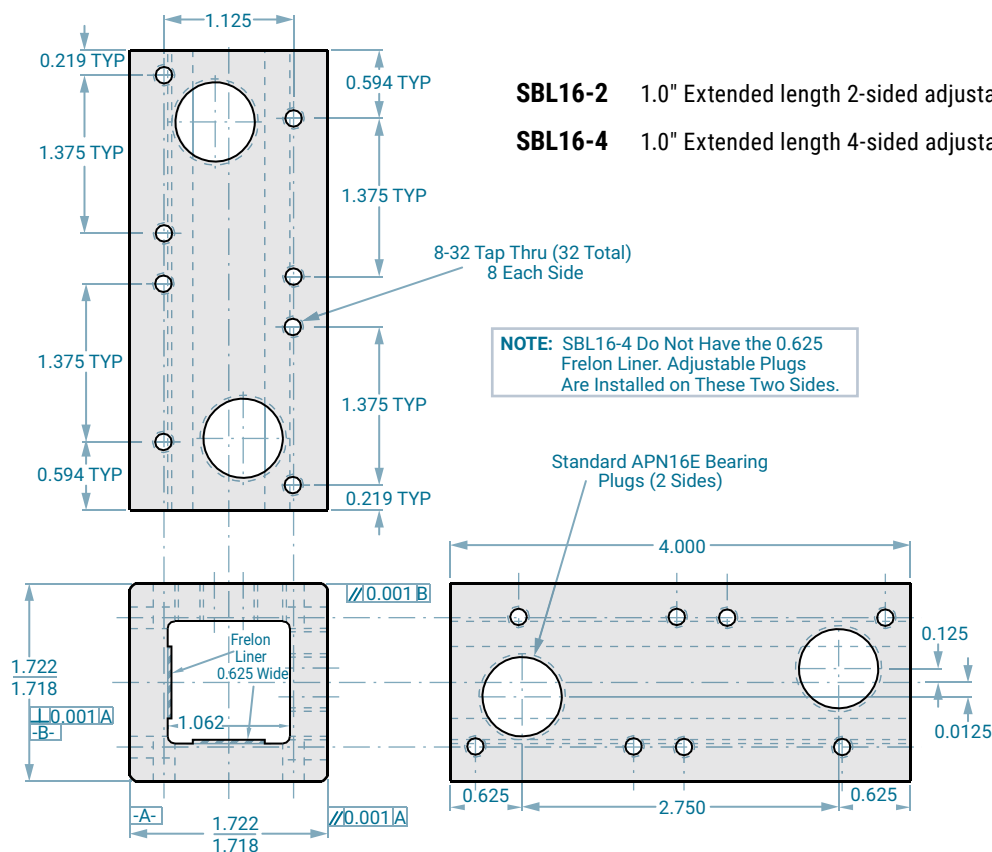

# Simplicity® 1.5 Inch • Square Bearings

## ORDERING INFORMATION

Part No.	Description	Bearing Weight lb.
SB24-2E	Standard 1.5" two-sided adjustable square bearing with Frelon® J plugs for stainless steel shafting.	0.96
SB24-2	Optional 1.5" two-sided adjustable square bearing with FrelonGOLD® plugs for steel shafting.	0.96
SB24-4E	Standard 1.5" four-sided adjustable square bearing with Frelon J plugs for stainless steel shafting.	1.12
SB24-4	Optional 1.5" four-sided adjustable square bearing with FrelonGOLD plugs for steel shafting.	1.12
SBL24-2E	Standard 1.5" extended length, two-sided adjustable square bearing with Frelon J plugs for stainless steel shafting.	1.71
SBL24-2	Optional 1.5" extended length, two-sided adjustable square bearing with FrelonGOLD plugs for steel shafting.	1.71
SBL24-4E	Standard 1.5" extended length, four-sided adjustable square bearing with Frelon J plugs for stainless steel shafting.	1.84
SBL24-4	Optional 1.5" extended length, four-sided adjustable square bearing with FrelonGOLD plugs for steel shafting.	1.84

**SB24-2** 1.5" 2-Sided adjustable square bearing

**SB24-4** 1.5" 4-Sided adjustable square bearing

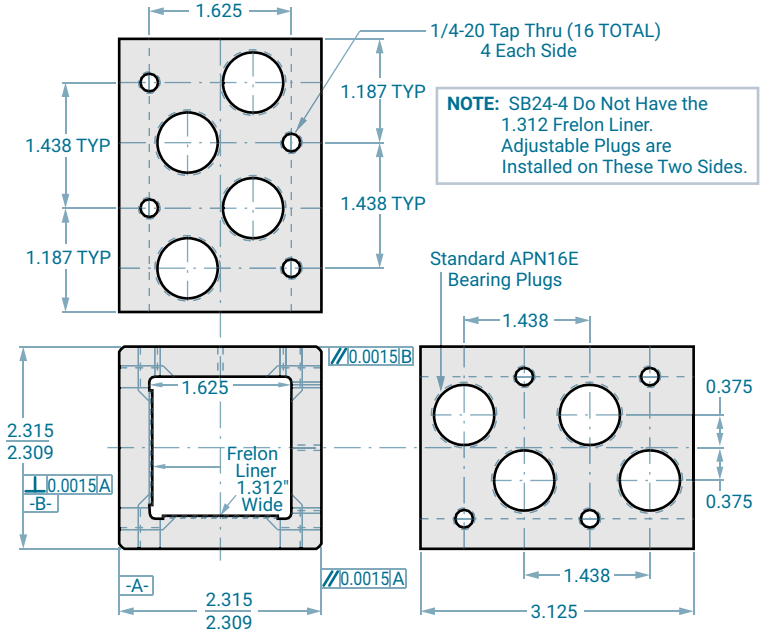

**SBL24-2** 1.5" Extended length 2-sided adjustable square bearing

**SBL24-4** 1.5" Extended length 4-sided adjustable square bearing

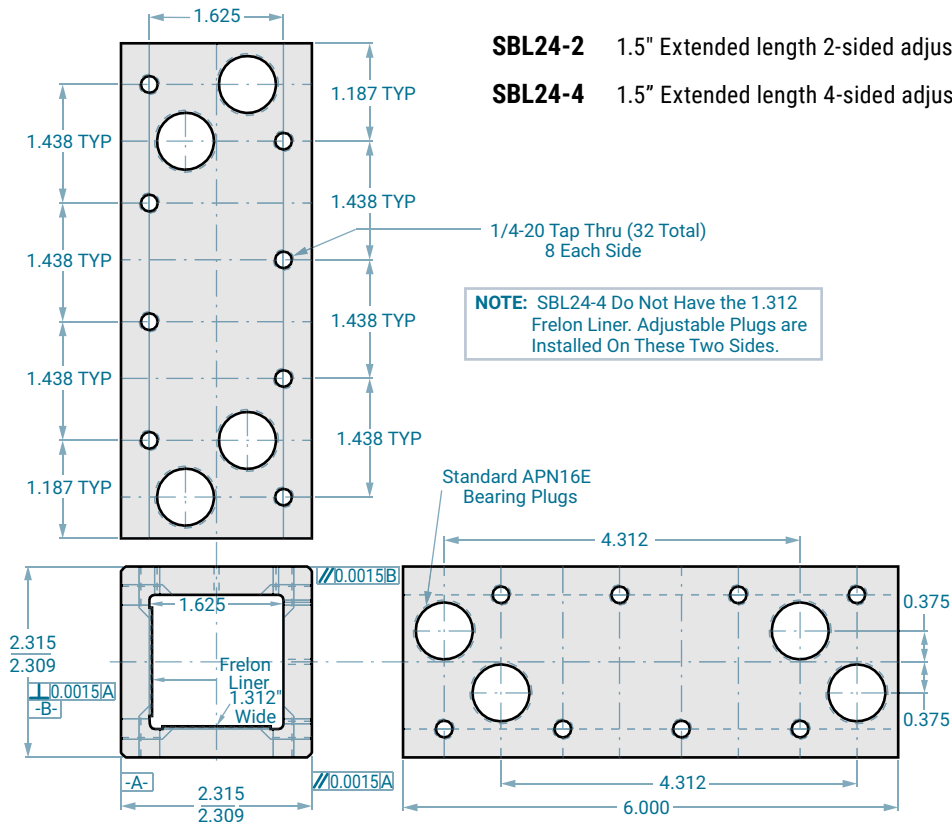

# Simplicity® Square Shafting & Accessories

## Square Shafting

- 304 Stainless steel (standard) is highly corrosion resistant
- Buffed and polished to provide an excellent running surface for Frelon® J
- Both 1" and 1.5" available cut to any length up to 20 feet
- Wall thickness is  $\approx 0.120"$

Part No.	Description	Weight lb./in.
PST16-xxx.xxx	Standard 1.0" 304 stainless steel square shafting.	0.12
PST24-xxx.xxx	Standard 1.5" 304 stainless steel square shafting.	0.18

**Note:** Specify length in part number using inches.  
Example: for 1.0" shafting total length 15" = PST16-015.000.

## Steel Shafting PST

Specify length in inches

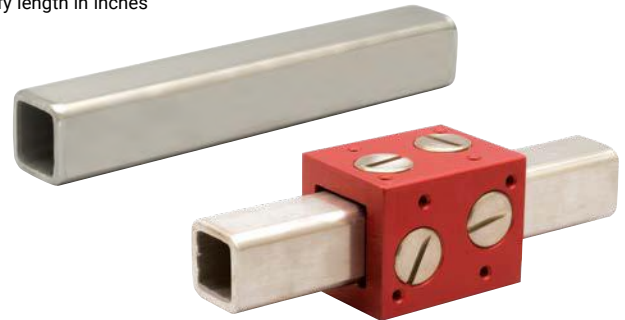

## Mounting Accessories

All mounting accessories are made from cast 356-T6 aluminum for good strength and corrosion resistance.



**Square Clamp PFL**  
Includes: 2 M6 x 1 Hex head bolts

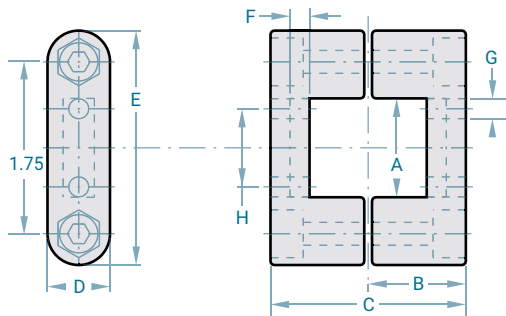

PART NO.	A	B	C	D	E	F	G	H
PFL1000	1.00	0.984	1.968	0.630	2.362	0.197	0.200	0.787
PFL1500	1.50	1.338	2.677	0.787	2.953	0.276	0.256	1.024

**Cross Mount P XK1515**  
1-1/2" only



**Cross Mount Round & Square P XM1515**  
1-1/2" only



**Flange Base PBH1000**

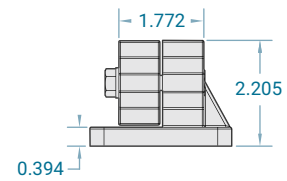
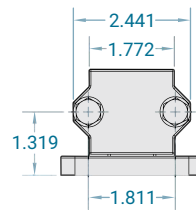
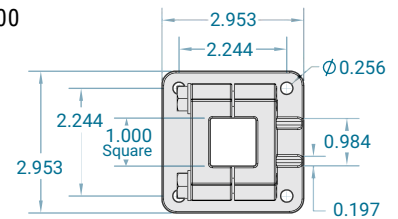

**Flange Base PBH1500**

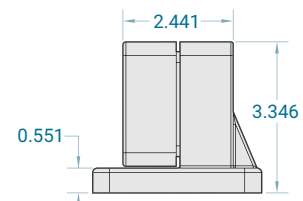
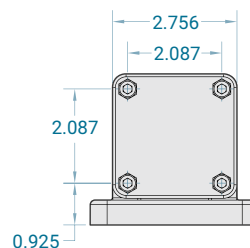
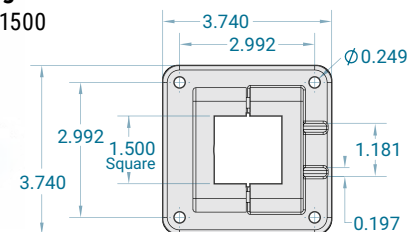

# Simplicity® Linear Plain Bearings

INCH

ISO METRIC

JIS METRIC

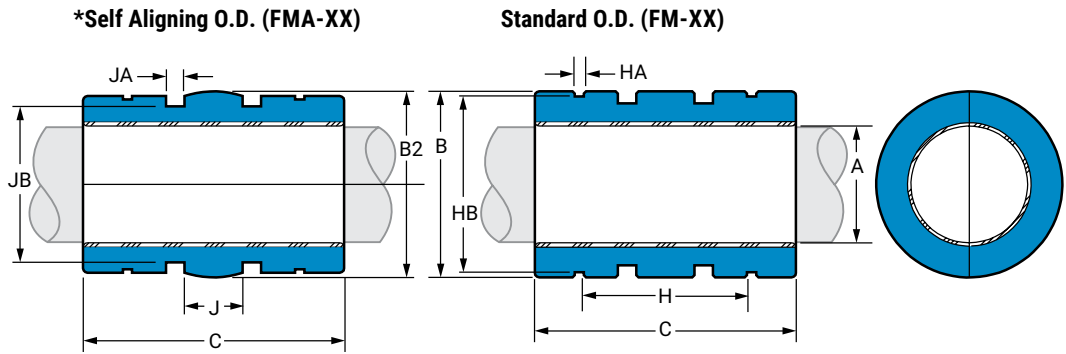
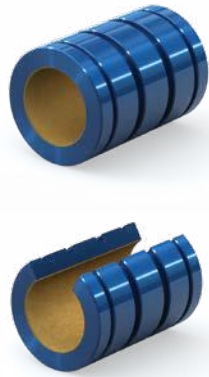

\*Except for the O.D., bearings with the self-aligning feature have the same dimensions and tolerances as the standard bearing. There is a spherical crown on the O.D. to create the self-aligning feature. They are for use in a straight bore housing. Add an "A" to the part number for self-aligning bearings.

## DIMENSIONAL INFORMATION

Precision I.D. Series Similar to Preloaded Ball Bearing					Compensated I.D. Series Similar to Standard Ball Bearing				B		B2		C Length		Concentric	Bearing Weight
Part No.		Nominal Size	A Bearing I.d. F8		Part No.		A Bearing I.d.		Standard O.d. H7		Self-Aligning O.D. FMA		MIN	MAX	MAX mm	Kg.
Closed	Open	mm	MIN	MAX	Closed	Open	MIN	MAX	MIN	MAX	MIN	MAX	MIN	MAX		
FM 05	FMN 05	5	5.010	5.028	FMC 05	FMCN 05	5.060	5.078	11.982	12	11.941	11.966	21.619	22	0.0254	0.004
FM 08	FMN 08	8	8.013	8.035	FMC 08	FMCN 08	8.063	8.085	15.982	16	15.941	15.966	24.619	25	0.0254	0.009
FM 10	FMN 10	10	10.013	10.035	FMC 10	FMCN 10	10.063	10.085	18.979	19	18.938	18.964	28.619	29	0.0254	0.014
FM 12	FMN 12	12	12.016	12.043	FMC 12	FMCN 12	12.066	12.093	21.979	22	21.938	21.963	31.619	32	0.0254	0.017
FM 16	FMN 16	16	16.016	16.043	FMC 16	FMCN 16	16.066	16.093	25.979	26	25.938	25.964	35.619	36	0.0254	0.028
FM 20	FMN 20	20	20.020	20.053	FMC 20	FMCN 20	20.096	20.129	31.975	32	31.938	31.963	44.619	45	0.0254	0.054
FM 25	FMN 25	25	25.020	25.053	FMC 25	FMCN 25	25.096	25.129	39.975	40	39.936	39.962	57.619	58	0.0254	0.109
FM 30	FMN 30	30	30.020	30.053	FMC 30	FMCN 30	30.096	30.129	46.975	47	46.937	46.962	67.619	68	0.0254	0.176
FM 40	FMN 40	40	40.025	40.064	FMC 40	FMCN 40	40.127	40.166	61.970	62	61.935	61.961	79.619	80	0.0254	0.356
FM 50	FMN 50	50	50.025	50.064	FMC 50	FMCN 50	50.127	50.166	74.970	75	74.935	74.960	99.619	100	0.0254	0.628
FM 60	FMN 60	60	60.030	60.076	FMC 60	FMCN 60	60.182	60.228	89.965	90	89.931	89.957	124.619	125	0.0380	1.117
FM 80	FMN 80	80	80.030	80.076	FMC 80	FMCN 80	80.182	80.228	119.965	120	119.931	119.957	164.619	165	0.0510	2.679

## MOUNTING DIMENSIONS

Part No.		Nominal Size	H	HA	HB	Ret. Ring Part No.	J	JA	JB	Metric O'ring Size
Closed	Open	mm	Between Ret. Rings	Ret. Ring GRV. Width	Ret. Ring GRV. Dia.	Din 471	Between O'ring GRVS.	O'ring GRV. Width	O'ring GRV. Dia.	
FM 05	FMN 05	5	12	1.14	11.5	12	5	2	9.86	9.7 x 1.3
FM 08	FMN 08	8	14	1.14	15.2	16	5.33	2	13.2	13 x 1.7
FM 10	FMN 10	10	19.4	1.32	18.0	19	5.63	2.44	15.7	15.5 x 2
FM 12	FMN 12	12	20	1.32	21.0	22	6	3.17	17.9	17.5 x 2.5
FM 16	FMN 16	16	22	1.32	24.9	26	8	3.17	21.9	21.5 x 2.5
FM 20	FMN 20	20	28	1.63	30.3	32	10	3.17	27.9	27.5 x 2.5
FM 25	FMN 25	25	40	1.90	37.5	40	12.5	3.17	35.9	35.5 x 2.5
FM 30	FMN 30	30	48	1.90	44.5	47	15	3.17	42.7	42.52 x 2.62
FM 40	FMN 40	40	56	2.20	59.0	62	20	4.1	56.3	56 x 3.5
FM 50	FMN 50	50	72	2.70	72.0	75	25	4.1	69.2	69 x 3.5
FM 60	FMN 60	60	95	3.20	86.4	90	30	7.1	81.7	81 x 5
FM 80	FMN 80	80	125	4.17	116.1	120	40	7.1	111.7	111 x 5

# Simplicity® Linear Plain Bearings

## Linear Plain Bearings FMN

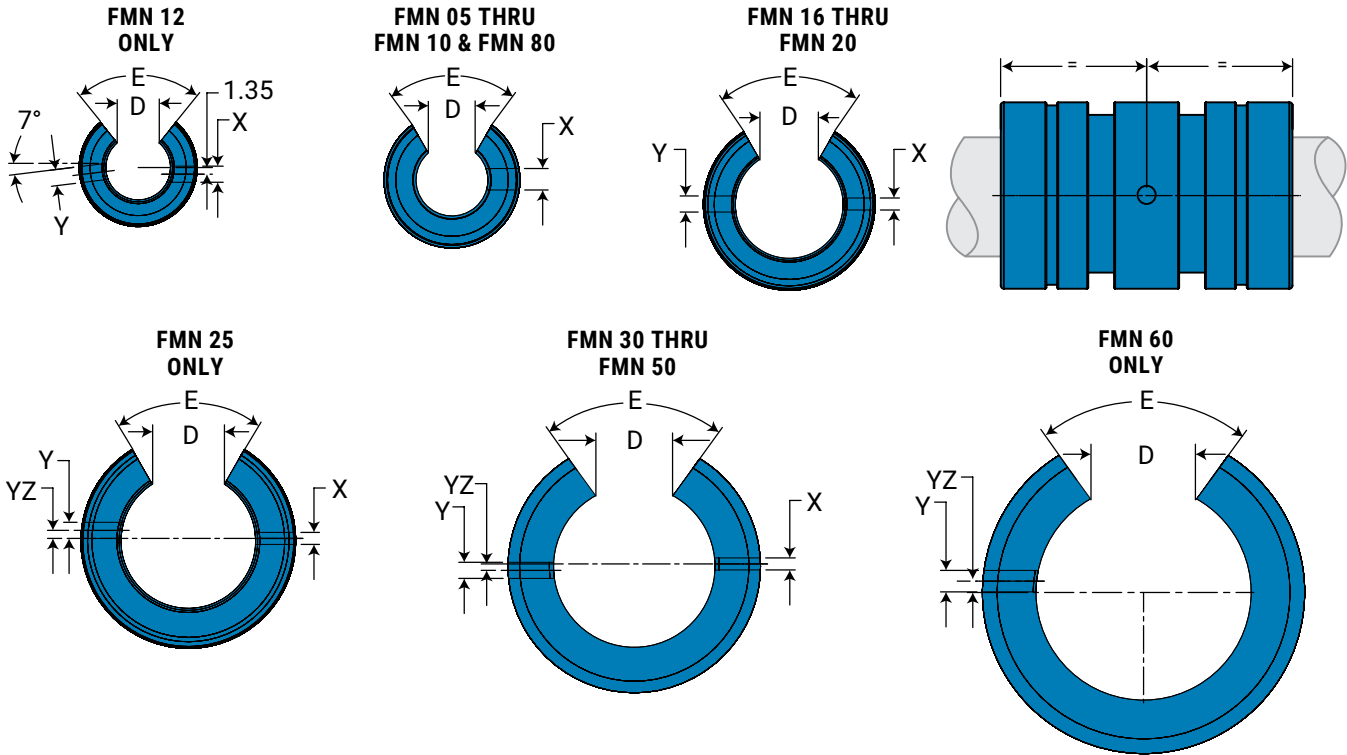

INCH

ISO METRIC

JIS METRIC

### OPEN DIMENSIONAL INFORMATION

Part No.	Nominal Size mm	D Slot Wide MIN	E Slot Angle	X Ret. Hole Dia.	Y Ret. Hole Dia.	Yz Ret. Hole Locate	Bearing Wt. Kg.
FMN 05	5	3.2	60	2.2	N/A	N/A	0.0034
FMN 08	8	5.1	60	3.0	N/A	N/A	0.0077
FMN 10	10	6.4	60	3.0	N/A	N/A	0.0119
FMN 12	12	7.6	78	3.0	3.0	7.0	0.0156
FMN 16	16	10.4	78	2.2	3.0	0	0.0213
FMN 20	20	10.8	60	2.2	3.0	0	0.0439
FMN 25	25	13.2	60	3.0	3.0	1.5	0.0893
FMN 30	30	14.2	72	3.0	3.0	2.0	0.1460
FMN 40	40	19.5	72	3.0	3.0	1.5	0.2948
FMN 50	50	24.0	72	3.0	5.0	2.5	0.5202
FMN 60	60	29.6	72	N/A	6.0	0	0.9199
FMN 80	80	39.0	72	N/A	8.0	0	2.2269

### LOAD & SPEED DATA

Part No.	Effective Surface Area sq. in.	MAX Static Load lb. Frelon®		Effective Surface Area CM <sup>2</sup>	MAX Static Load N Frelon	
		GOLD	J		GOLD	J & W
FMN 05	0.171	511	256	1.10	2276	1138
FMN 08	0.310	926	463	2.00	4120	2060
FMN 10	0.450	1345	672	2.90	5984	2992
FMN 12	0.589	1777	888	3.80	7907	3953
FMN 16	0.899	2667	1334	5.80	11870	5935
FMN 20	1.395	4167	2083	9.00	18541	9270
FMN 25	2.248	6715	3358	14.50	29881	14941
FMN 30	3.162	9444	4722	20.40	42026	21013
FMN 40	4.960	14814	7407	32.00	65923	32962
FMN 50	7.750	23147	11574	50.00	103005	51503
FMN 60	11.625	34721	17360	75.00	154508	77254
FMN 80	20.460	61120	30554	132.00	271933	135967

Note: MAX PV (m/min. \* kg/sq. cm)

FrelonGOLD® = 430 PV

Frelon J = 215 PV

MAX Speed Running Dry (m/min.)

FrelonGOLD = 91.4

Frelon J = 42.6

MAX Speed Running

with Lubrication (m/min.)

FrelonGOLD = 251.5

Frelon J = 122

MAX PV (m/s. \* N/mm<sup>2</sup>)

FrelonGOLD = 0.70 PV

Frelon J = 0.35 PV

MAX Speed Running Dry (m/s)

FrelonGOLD = 1.52

Frelon J = 0.71

MAX Speed Running

with Lubrication (m/s)

FrelonGOLD = 4.19

Frelon J = 2.03



**Plain Bearing Accessories:**  
Retaining Rings, Seals, O-Rings—page 29



**Only certified Simplicity 60 Plus Shafting provides maximum linear bearing performance.**

**Inch Series—page 52 Metric Series—page 90**

# Simplicity® Thin Wall Bearings

## Plain Bearings – Compact Thin Wall FG

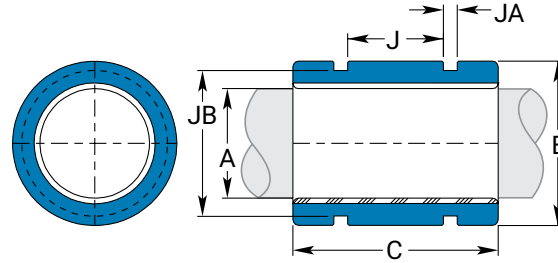
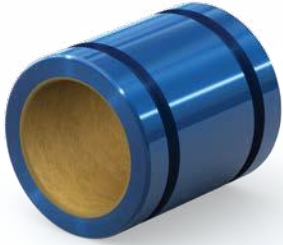

### DIMENSIONAL INFORMATION

Precision I.D. Series Similar to Preloaded Ball Bearing				Compensated I.D. Series Similar to Standard Ball Bearing			B O.D. H7		C Length		Concentric	Bearing Weight
Part No. Closed	Nominal Size mm	A Bearing I.D. F8 MIN MAX		Part No. Closed	A Bearing I.D. MIN MAX		MIN	MAX	MIN	MAX	MAX mm	Kg.
FG 06	6	6.010	6.028	FGC 06	6.060	6.078	11.98	12	17.619	18	0.0254	0.004
FG 08	8	8.013	8.035	FGC 08	8.063	8.085	14.98	15	19.619	20	0.0254	0.006
FG 10	10	10.013	10.035	FGC 10	10.063	10.085	16.98	17	21.619	22	0.0254	0.008
FG 12	12	12.016	12.043	FGC 12	12.066	12.093	21.98	22	26.619	27	0.0254	0.018
FG 15	15	15.016	15.043	FGC 15	15.066	15.093	24.98	25	27.619	28	0.0254	0.022
FG 16	16	16.016	16.043	FGC 16	16.066	16.093	25.98	26	29.619	30	0.0254	0.025
FG 18	18	18.020	18.053	FGC 18	18.096	18.129	27.98	28	29.619	30	0.0254	0.027
FG 20	20	20.020	20.053	FGC 20	20.096	20.129	31.98	32	34.619	35	0.0254	0.044
FG 25	25	25.020	25.053	FGC 25	25.096	25.129	39.98	40	44.619	45	0.0254	0.091
FG 30	30	30.020	30.053	FGC 30	30.096	30.129	44.98	45	53.619	54	0.0254	0.127
FG 35	35	35.025	35.064	FGC 35	35.127	35.166	51.98	52	61.619	62	0.0254	0.189
FG 40	40	40.025	40.064	FGC 40	40.127	40.166	59.98	60	71.619	72	0.0254	0.301
FG 50	50	50.025	50.064	FGC 50	50.127	50.166	74.98	75	89.619	90	0.0254	0.596

### MOUNTING DIMENSIONS

Part No.		Nominal Size	J Between O-Ring GRVS.	Ja O-Ring GRV. Width	Jb O-Ring GRV. Dia.	O-Ring Size	O-Ring Part Number
Precision	Compensated						
FG 06	FGC 06	6	N/A	N/A	N/A	N/A	N/A
FG 08	FGC 08	8	8.0	2.032	12.201	12 x 1.7	6000025
FG 10	FGC 10	10	8.3	2.032	14.415	14 x 1.6	6000026
FG 12	FGC 12	12	12.0	3.175	17.907	17.5 x 2.5	6000016
FG 15	FGC 15	15	12.7	3.175	20.671	20 x 2.65	6000029
FG 16	FGC 16	16	12.7	3.175	21.882	21.5 x 2.5	6000017
FG 18	FGC 18	18	14.0	3.175	23.885	23.5 x 2.5	6000031
FG 20	FGC 20	20	17.0	3.175	27.864	27.5 x 2.5	6000018
FG 25	FGC 25	25	24.0	3.175	35.865	35.5 x 2.5	6000019
FG 30	FGC 30	30	30.0	3.175	40.895	40 x 2.5	6000034
FG 35	FGC 35	35	36.0	4.115	46.200	46 x 3.5	6000035
FG 40	FGC 40	40	37.3	4.115	54.255	53 x 3.5	6000036
FG 50	FGC 50	50	50	4.115	69.215	69 x 3.5	6000022

### LOAD & SPEED DATA

Part No.	Effective Surface Area CM <sup>2</sup>	Max Static Load lb. Frelon®		Effective Surface Area CM <sup>2</sup>	MAX Static Load N Frelon	
		GOLD	J & W		GOLD	J & W
FG 06	1.1	498	249	1.10	2217	1109
FG 08	1.6	741	370	1.60	3296	1648
FG 10	2.2	1018	509	2.20	4532	2266
FG 12	3.2	1499	749	3.20	6671	3335
FG 15	4.2	1944	972	4.20	8652	4326
FG 16	4.8	2222	1111	4.80	9888	4944
FG 18	5.4	2500	1250	5.40	11125	5562
FG 20	7.0	3241	1620	7.00	14421	7210
FG 25	11.3	5207	2604	11.30	23171	11586
FG 30	16.2	7500	3750	16.20	33374	16687
FG 35	21.7	10048	5024	21.70	44714	22357
FG 40	28.8	13333	6666	28.80	59331	29665
FG 50	45.0	20833	10416	45.00	92705	46352

Plain Bearing Accessories: Retaining Rings, Seals, O-Rings page 29



Only certified Simplicity 60 Plus Shafting provides maximum linear bearing performance.

Inch Series—page 52 Metric Series—page 90

Note: MAX PV (m/min. \* kg/sq. cm)

FrelonGOLD® = 430 PV

Frelon J = 215 PV

MAX Speed Running Dry (m/min.)

FrelonGOLD = 91.4

Frelon J = 42.6

MAX Speed Running with Lubrication (m/min.)

FrelonGOLD = 251.5

Frelon J = 122

MAX PV (m/s. \* N/mm<sup>2</sup>)

FrelonGOLD = 0.70 PV

Frelon J = 0.35 PV

MAX Speed Running Dry (m/s)

FrelonGOLD = 1.52

Frelon J = 0.71

MAX Speed Running with Lubrication (m/s)

FrelonGOLD = 4.19

Frelon J = 2.03

# Simplicity® Thin Wall Bearings

## Plain Bearings – Compact Thin Wall FMT

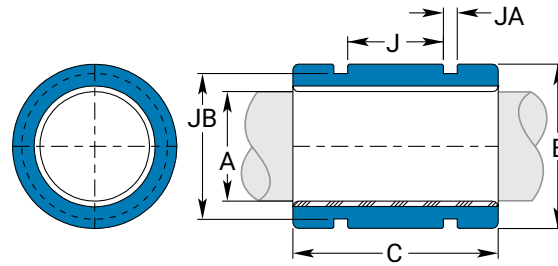
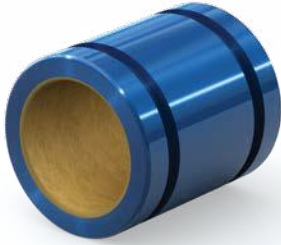

### DIMENSIONAL INFORMATION

Precision I.D. Series Similar to Preloaded Ball Bearing				Compensated I.D. Series Similar to Standard Ball Bearing			B O.D. H7		C Length		Concentric	Bearing Weight
Part No.	Nominal Size	A Bearing I.D. F8		Part No.	A Bearing I.D.		MIN	MAX	MIN	MAX	MAX mm	Kg.
Closed	mm	MIN	MAX	Closed	MIN	MAX						
FMT 06	6	6.010	6.028	FMTC 06	6.060	6.078	11.982	12	21.619	22	0.0254	0.0057
FMT 08	8	8.013	8.035	FMTC 08	8.063	8.085	14.982	15	23.619	24	0.0254	0.0071
FMT 10	10	10.013	10.035	FMTC 10	10.063	10.085	16.982	17	25.619	26	0.0254	0.0085
FMT 12	12	12.016	12.043	FMTC 12	12.066	12.093	18.979	19	27.619	28	0.0254	0.0113
FMT 14	14	14.016	14.043	FMTC 14	14.066	14.093	20.979	21	27.619	28	0.0254	0.0128
FMT 16	16	16.016	16.043	FMTC 16	16.066	16.093	23.979	24	29.619	30	0.0254	0.0184
FMT 20	20	20.020	20.053	FMTC 20	20.096	20.129	27.979	28	29.619	30	0.0254	0.0227
FMT 25	25	25.020	25.053	FMTC 25	25.096	25.129	34.975	35	39.619	40	0.0254	0.0439
FMT 30	30	30.020	30.053	FMTC 30	30.096	30.129	39.975	40	49.619	50	0.0254	0.0652
FMT 40	40	40.025	40.064	FMTC 40	40.127	40.166	51.970	52	59.619	60	0.0254	0.1233
FMT 50	50	50.025	50.064	FMTC 50	50.127	50.166	61.970	62	69.619	70	0.0254	0.1772

### MOUNTING DIMENSIONS

Part No.		Nominal Size	J Between O-Ring GRVS.	JA O-Ring GRV. Width	JB O-Ring GRV. Dia.	O-Ring Size	O-Ring Part Number
Precision	Compensated						
FMT 06	FMTC 06	6	N/A	N/A	N/A	N/A	N/A
FMT 08	FMTC 08	8	10.0	2.000	12.200	12 x 1.7	6000025
FMT 10	FMTC 10	10	12.0	2.000	14.400	14 x 1.6	6000026
FMT 12	FMTC 12	12	14.0	2.000	16.600	16 x 1.5	6000027
FMT 14	FMTC 14	14	14.0	2.000	18.500	18 x 1.5	6000028
FMT 16	FMTC 16	16	14.0	2.000	21.300	21.1 x 1.6	6000030
FMT 20	FMTC 20	20	14.0	2.000	25.500	25 x 1.5	6000032
FMT 25	FMTC 25	25	22.0	3.200	30.900	30.5 x 2.5	6000033
FMT 30	FMTC 30	30	30.0	3.200	35.900	35.5 x 2.5	6000019
FMT 40	FMTC 40	40	40.0	4.100	46.200	46 x 3.5	6000035
FMT 50	FMTC 50	50	50.0	4.100	56.300	26 x 3.5	6000021

### LOAD & SPEED DATA

Part No.	Effective Surface Area CM <sup>2</sup>	Max Static Load lb. Frelon®		Effective Surface Area CM <sup>2</sup>	MAX Static Load N Frelon	
		GOLD	J & W		GOLD	J & W
FMT 06	0.202	613	307	1.3	2727	1364
FMT 08	0.295	891	445	1.9	3963	1982
FMT 10	0.403	1204	602	2.6	5356	2678
FMT 12	0.527	1556	778	3.4	6926	3463
FMT 14	0.605	1816	908	3.9	8083	4042
FMT 16	0.744	2222	1111	4.8	9888	4944
FMT 20	0.930	2778	1389	6.0	12361	6180
FMT 25	1.550	4629	2315	10.0	20601	10301
FMT 30	2.325	6944	3472	15.0	30902	15451
FMT 40	3.720	11111	5555	24.0	49442	24721
FMT 50	5.425	16203	8102	35.0	72104	36052

**Note:** MAX PV (m/min. \* kg/sq. cm)

FrelonGOLD® = 430 PV

Frelon J = 215 PV

MAX Speed Running Dry (m/min.)

FrelonGOLD = 91.4

Frelon J = 42.6

MAX Speed Running

with Lubrication (m/min.)

FrelonGOLD = 251.5

Frelon J = 122

MAX PV (m/s. \* N/mm<sup>2</sup>)

FrelonGOLD = 0.70 PV

Frelon J = 0.35 PV

MAX Speed Running Dry (m/s)

FrelonGOLD = 1.52

Frelon J = 0.71

MAX Speed Running

with Lubrication (m/s)

FrelonGOLD = 4.19

Frelon J = 2.03



**Plain Bearing Accessories: Retaining Rings, Seals, O-Rings**  
page 29



**Only certified Simplicity 60 Plus Shafting provides maximum linear bearing performance.**

**Inch Series—page 52 Metric Series—page 90**

# Simplicity® Closed Pillow Blocks

## Plain Bearings – Closed Pillow Blocks PM

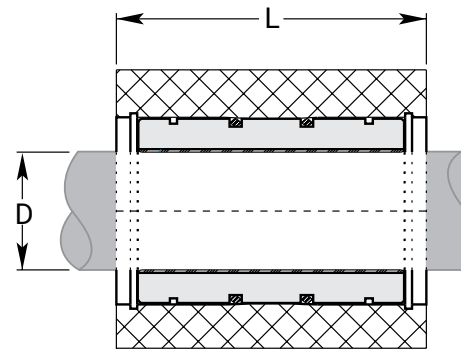
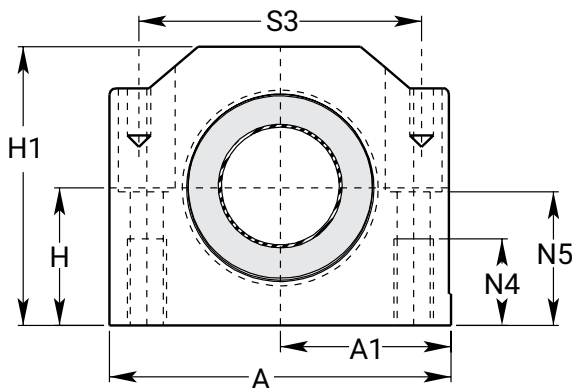
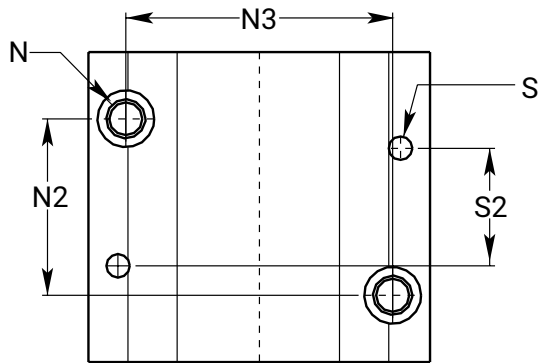

### DIMENSIONAL INFORMATION

Part No.	D Nom. Brg. I.D.	H Centerline	H1 Height	A Width	A1 0.013	L Length	N Bolt	N2	N3	N4	N5	S	S2	S3	Max Static Load lb.		Max Static Load N		Assem. WT. Kg.	
															Frelon® GOLD	J & W	Frelon GOLD	J & W		
PM 08	PM 08 C	8	15	28	35	17.5	32	M4 x 0.7	20	25	9	14.5	N/A	N/A	N/A	926	463	4120	2060	0.069
PM 10	PM 10 C	10	16	31.5	40	20	36	M5 x 0.8	20	29	11	15	4	29	31	1345	672	5984	2992	0.095
PM 12	PM 12 C	12	18	35	43	21.5	39	M5 x 0.8	23	32	11	16.5	4	32	34	1777	888	7907	3953	0.118
PM 16	PM 16 C	16	22	42	53	26.5	43	M6 x 1.0	26	40	13	21	4	35	42	2667	1334	11870	5935	0.200
PM 20	PM 20 C	20	25	50	59.3	30	54	M8 x 1.25	32	45	18	24	5	45	50	4167	2083	18541	9270	0.329
PM 25	PM 25 C	25	30	60	78	39	67	M10 x 1.5	40	60	22	29	6	20	64	6715	3358	29881	14941	0.655
PM 30	PM 30 C	30	35	71	87	43.5	79	M10 x 1.5	45	68	22	34	6	30	72	9444	4722	42026	21013	1.020
PM 40	PM 40 C	40	45	91	108	54	91	M12 x 1.75	58	86	26	44	8	35	90	14814	7407	65923	32962	1.846
PM 50	PM 50 C	50	50	105	132	66	113	M16 x 2.0	50	108	34	49	10	42	108	23147	11574	103005	51503	3.169

Notes: (1) Standard pillow block assembly includes self-aligning housing and precision bearing.  
 (2) All standard metric pillow blocks use standard FM series bearings.  
 (3) Straight bore pillow block assembly includes standard O.D. FM series bearing in straight bore housing.



**Only certified Simplicity 60 Plus Shafting provides maximum linear bearing performance.**

**Inch Series—page 52 Metric Series—page 90**

# Simplicity® Open Pillow Blocks

## Plain Bearings – Open Pillow Blocks PMN

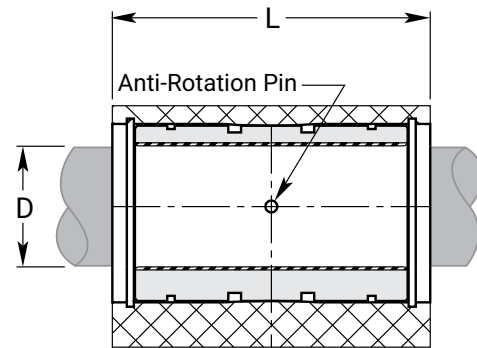
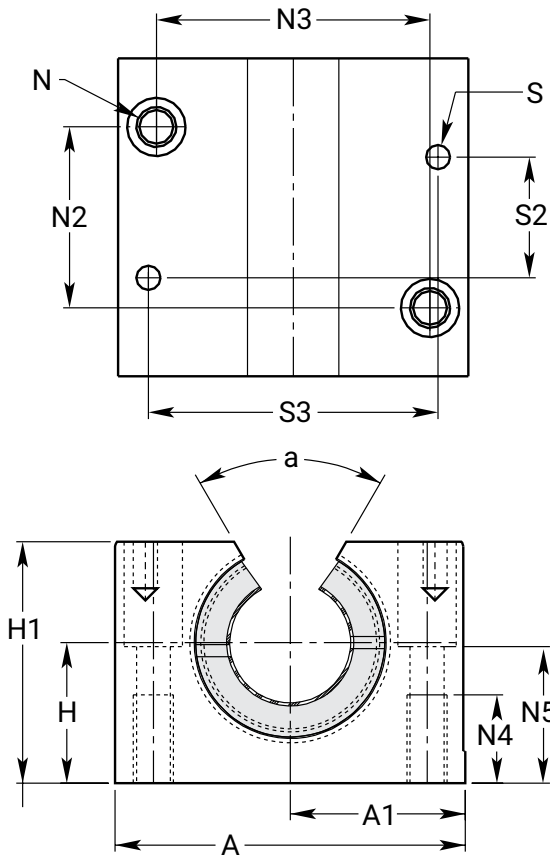

INCH

ISO METRIC

JIS METRIC

### DIMENSIONAL INFORMATION

Part No.	D Nom. Brg. I.d.	H Centerline	H1 Height	A Width	A1 0.013	L Length	N Bolt	N2	N3	N4	N5	S	S2	S3	A mm	Max Static Load lb.		Max Static Load N		Assem. WT. Kg.	
																Frelon® GOLD	J & W	Frelon GOLD	J & W		
PMN 12 Open Precision	PMN 12C Compensated	12	18	28	43	21.5	39	M5 x 0.8	23	32	11	16.5	4	32	34	66	1777	888	7907	3953	0.096
PMN 16	PMN 16C	16	22	35	53	26.5	43	M6 x 1.0	26	40	13	21	4	35	42	68	2667	1334	11870	5935	0.162
PMN 20	PMN 20C	20	25	42	60	30	54	M8 x 1.25	32	45	18	24	5	45	50	60	4167	2083	18541	9270	0.267
PMN 25	PMN 25C	25	30	51	78	39	67	M10 x 1.5	40	60	20	29	6	20	64	60	6715	3358	29881	14941	0.536
PMN 30	PMN 30C	30	35	60	87	43.5	79	M10 x 1.5	45	68	22	34	6	30	72	60	9444	4722	42026	21013	0.831
PMN 40	PMN 40C	40	45	77	108	54	91	M12 x 1.75	58	86	26	44	8	35	90	60	14814	7407	65923	32962	1.499
PMN 50	PMN 50C	50	50	88	132	66	113	M16 x 2.0	50	108	34	49	10	42	108	60	23147	11574	103005	51503	2.539



Only certified Simplicity 60 Plus Shafting provides maximum linear bearing performance.

Inch Series—page 52 Metric Series—page 90

# Simplicity® Flange Bearings

## Flange Bearings SFPM

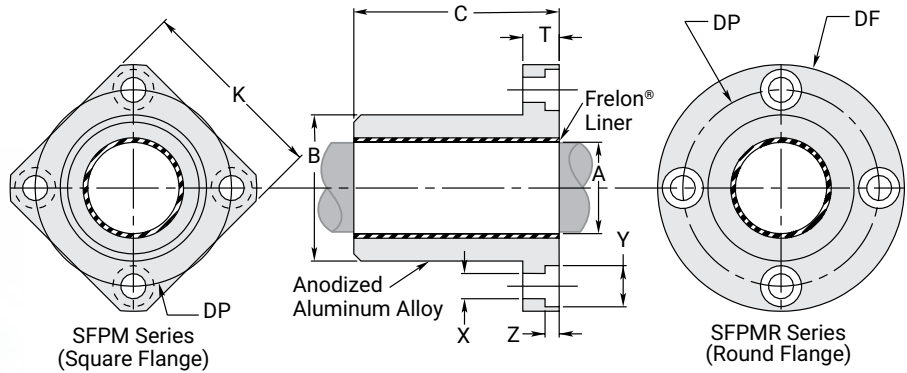

### DIMENSIONAL INFORMATION

Precision I.D. Series Similar to Preloaded Ball Bearing				Compensated I.D. Series Similar to Standard Ball Bearing				Nominal Size	B Body O.D. H7		C Length H13		Effective Surface Area CM <sup>2</sup>	Max Static Load N	
Part No.		A Bearing I.D. F8		Part No.		A Bearing I.d.			MIN	MAX	MIN	MAX		Frelon®	
Square	Round	MIN	MAX	Square	Round	MIN	MAX		mm					GOLD	J & W
SFPM 08	SFPMR 08	8.013	8.035	SFPM 08C	SFPMR 08C	8.063	8.085	8	15.982	16	24.8	25	2.094	4316	2168
SFPM 12	SFPMR 12	12.016	12.043	SFPM 12C	SFPMR 12C	12.066	12.093	12	21.979	22	31.8	32	4.021	8280	4159
SFPM 16	SFPMR 16	16.016	16.043	SFPM 16C	SFPMR 16C	16.066	16.093	16	25.979	26	35.8	36	6.032	12429	6239
SFPM 20	SFPMR 20	20.020	20.053	SFPM 20C	SFPMR 20C	20.096	20.129	20	31.975	32	44.8	45	9.425	19414	9751
SFPM 25	SFPMR 25	25.020	25.053	SFPM 25C	SFPMR 25C	25.096	25.129	25	39.975	40	57.7	58	15.184	31284	15706
SFPM 30	SFPMR 30	30.020	30.053	SFPM 30C	SFPMR 30C	30.096	30.129	30	46.975	47	67.7	68	21.363	44008	22102
SFPM 40	SFPMR 40	40.025	40.064	SFPM 40C	SFPMR 40C	40.127	40.166	40	61.970	62	79.7	80	33.510	69033	34669
SFPM 50	SFPMR 50	50.025	50.064	SFPM 50C	SFPMR 50C	50.127	50.166	50	74.970	75	99.7	100	52.360	107871	54161
SFPM 60	SFPMR 60	60.030	60.076	SFPM 60C	SFPMR 60C	60.182	60.228	60	89.965	90	124.6	125	78.540	161796	81246
SFPM 80	SFPMR 80	80.030	80.076	SFPM 80C	SFPMR 80C	80.182	80.228	80	119.965	120	164.6	165	138.230	284765	142991

- Notes: (1) Formula used for effective surface area is  $(\pi * ID * L)/3$ .  
 (2) Max static load is effective surface area times MAX load for FrelonGOLD®.  
 (3) - 210 kgf/cm<sup>2</sup> is the rating for FrelonGOLD; 105.45 kgf/cm<sup>2</sup> is the rating for Frelon J.

### MOUNTING DIMENSIONS

Part No.		K Square	DF O.D.	T Length	Dp Bolt Circle	X Hole	Y C'Bore Depth	Z C'Bore Depth	Clamping Bolt	Concentricity	Squareness	SFPM Weight Kg.	SFPMR Weight Kg.
Square	Round	MAX.	MAX.	MAX.									
SFPM 08	SFPMR 08	25	32	8	24	3.5	6	3.1	M 3	0.012	0.012	0.018	0.022
SFPM 12	SFPMR 12	32	42	9	32	4.5	7.5	4.1	M 4	0.012	0.012	0.037	0.046
SFPM 16	SFPMR 16	35	46	9	36	4.5	7.5	4.1	M 4	0.012	0.012	0.047	0.058
SFPM 20	SFPMR 20	42	54	11	43	5.5	9	5.1	M 5	0.015	0.015	0.085	0.101
SFPM 25	SFPMR 25	50	62	11	51	5.5	9	5.1	M 5	0.015	0.015	0.156	0.172
SFPM 30	SFPMR 30	60	76	14	62	6.6	11	6.1	M 6	0.015	0.015	0.257	0.293
SFPM 40	SFPMR 40	75	98	18	80	9.0	14	8.1	M 8	0.017	0.017	0.500	0.595
SFPM 50	SFPMR 50	88	112	18	94	9.0	14	8.1	M 8	0.017	0.017	0.825	0.930
SFPM 60	SFPMR 60	106	134	24	112	11.0	17	11.1	M 10	0.020	0.020	1.506	1.697
SFPM 80	SFPMR 80	136	164	24	142	11.0	17	11.1	M 10	0.020	0.020	3.308	3.483



Only certified Simplicity 60 Plus Shafting provides maximum linear bearing performance.

Inch Series—page 52 Metric Series—page 90

# Simplicity® Flange Bearings

## Flange Bearings DFPM

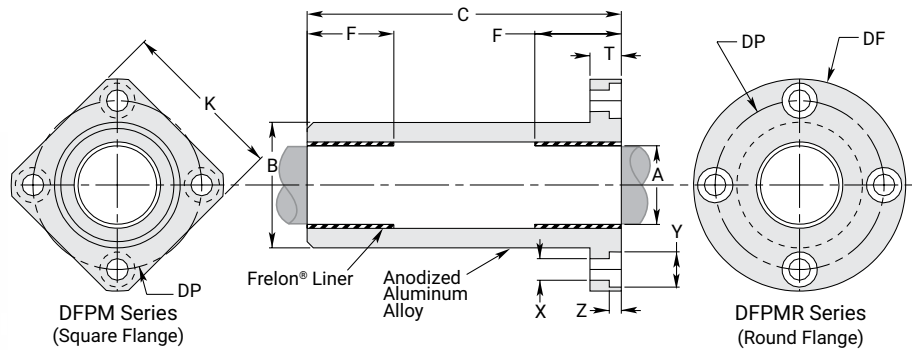

## DIMENSIONAL INFORMATION

Precision I.D. Series Similar to Preloaded Ball Bearing				Compensated I.D. Series Similar to Standard Ball Bearing				Nominal Size	B Body O.D. H7		C Length		F Length Each End	Effective Surface Area CM <sup>2</sup>	MAX Static Load N	
Part No.		A Bearing I.D. F8		Part No.		A Bearing I.D.			MIN	MAX	MIN	MAX			GOLd	J & W
Square	Round	MIN	MAX	Square	Round	MIN	MAX	MM	MIN	MAX	MIN	MAX				
DFPM 08	DFPMR 08	8.013	8.035	DFPM 08C	DFPMR 08C	8.063	8.085	8	15.982	16	44.7	45	12.1	2.027	4179	2099
DFPM 12	DFPMR 12	12.016	12.043	DFPM 12C	DFPMR 12C	12.066	12.093	12	21.979	22	56.7	57	15.4	3.870	7976	4002
DFPM 16	DFPMR 16	16.016	16.043	DFPM 16C	DFPMR 16C	16.066	16.093	16	25.979	26	69.7	70	20.4	6.836	14087	7073
DFPM 20	DFPMR 20	20.020	20.053	DFPM 20C	DFPMR 20C	20.096	20.129	20	31.975	32	79.7	80	22.1	9.257	19071	9575
DFPM 25	DFPMR 25	25.020	25.053	DFPM 25C	DFPMR 25C	25.096	25.129	25	39.975	40	111.6	112	33.1	17.331	35708	17933
DFPM 30	DFPMR 30	30.020	30.053	DFPM 30C	DFPMR 30C	30.096	30.129	30	46.975	47	122.6	123	35	21.991	45303	22749
DFPM 40	DFPMR 40	40.025	40.064	DFPM 40C	DFPMR 40C	40.127	40.166	40	61.970	62	150.6	151	44	36.861	75939	38131
DFPM 50	DFPMR 50	50.025	50.064	DFPM 50C	DFPMR 50C	50.127	50.166	50	74.970	75	191.6	192	69.5	72.780	149936	75282
DFPM 60	DFPMR 60	60.030	60.076	DFPM 60C	DFPMR 60C	60.182	60.228	60	89.965	90	208.6	209	73	91.735	188980	94892

- Notes:** (1) Formula used for effective surface area is  $(\pi * ID * L)/3$ .  
 (2) MAX static load is effective surface area times MAX load for FrelonGOLD®.  
 (3) - 210 kgf/cm<sup>2</sup> is the rating for FrelonGOLD®; 105.45 kgf/cm<sup>2</sup> is the rating for Frelon J.  
 (4) Frelon pads in each end (F dimension).

## MOUNTING DIMENSIONS

Part No.		K	DF	T	DP	X	Y	Z	Clamping Bolt	Concentricity	Squareness	DFPM Weight Kg.	DFPMR Weight Kg.
Square	Round	MAX	O.D. MAX	Length MAX	Bolt Circle	Hole	C'bore Depth	C'bore Depth					
DFPM 08	DFPMR 08	25	32	8	24	3.5	6	3.1	M 3	0.015	0.015	0.027	0.031
DFPM 12	DFPMR 12	32	42	9	32	4.5	7.5	4.1	M 4	0.015	0.015	0.055	0.064
DFPM 16	DFPMR 16	35	46	9	36	4.5	7.5	4.1	M 4	0.015	0.015	0.078	0.089
DFPM 20	DFPMR 20	42	54	11	43	5.5	9	5.1	M 5	0.017	0.017	0.133	0.149
DFPM 25	DFPMR 25	50	62	11	51	5.5	9	5.1	M 5	0.017	0.017	0.270	0.286
DFPM 30	DFPMR 30	60	76	14	62	6.6	11	6.1	M 6	0.017	0.017	0.413	0.450
DFPM 40	DFPMR 40	75	98	18	80	9.0	14	8.1	M 8	0.020	0.020	0.846	0.942
DFPM 50	DFPMR 50	88	112	18	94	9.0	14	8.1	M 8	0.020	0.020	1.450	1.556
DFPM 60	DFPMR 60	106	134	24	112	11.0	17	11.1	M 10	0.025	0.025	2.329	2.519



**Only certified Simplicity 60 Plus Shafting provides maximum linear bearing performance.**

**Inch Series—page 52 Metric Series—page 90**

# Simplicity® Flange Bearings

## Flange Bearings CFPM

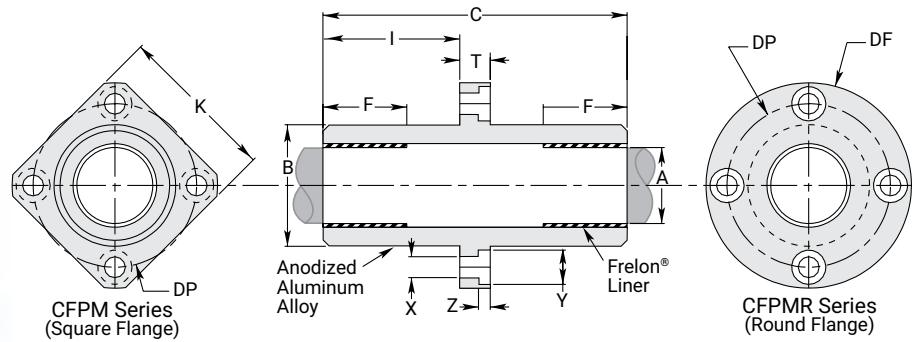

## DIMENSIONAL INFORMATION

Precision I.D. Series Similar to Preloaded Ball Bearing				Compensated I.D. Series Similar to Standard Ball Bearing				Nominal Size	B		C		I Length to Flng.	F Length Each End	Effective Surface Area CM <sup>2</sup>	MAX Static Load N	
Part No.		A Bearing I.D. F8		Part No.		A Bearing I.D.			MIN	MAX	MIN	MAX				Frelon® GOLD	J & W
Square	Round	MIN	MAX	Square	Round	MIN	MAX	mm	MIN	MAX	MIN	MAX					
CFPM 08	CFPMR 08	8.013	8.035	CFPM 08C	CFPMR 08C	8.063	8.085	8	15.982	16	45.7	46.3	19.0	12.1	2.027	4179	2099
CFPM 12	CFPMR 12	12.016	12.043	CFPM 12C	CFPMR 12C	12.066	12.093	12	21.979	22	60.7	61.3	26.0	15.4	3.870	7976	4002
CFPM 16	CFPMR 16	16.016	16.043	CFPM 16C	CFPMR 16C	16.066	16.093	16	25.979	26	67.7	68.3	29.5	20.4	6.836	14087	7073
CFPM 20	CFPMR 20	20.020	20.053	CFPM 20C	CFPMR 20C	20.096	20.129	20	31.975	32	79.7	80.3	34.5	22.1	9.257	19071	9575
CFPM 25	CFPMR 25	25.020	25.053	CFPM 25C	CFPMR 25C	25.096	25.129	25	39.975	40	111.7	112.3	50.5	33.1	17.331	35708	17933
CFPM 30	CFPMR 30	30.020	30.053	CFPM 30C	CFPMR 30C	30.096	30.129	30	46.975	47	122.7	123.3	54.5	35	21.991	45303	22749
CFPM 40	CFPMR 40	40.025	40.064	CFPM 40C	CFPMR 40C	40.127	40.166	40	61.970	62	150.7	151.3	66.5	44	36.861	75939	38131
CFPM 50	CFPMR 50	50.025	50.064	CFPM 50C	CFPMR 50C	50.127	50.166	50	74.970	75	191.7	192.3	87.0	69.5	72.780	149936	75282
CFPM 60	CFPMR 60	60.030	60.076	CFPM 60C	CFPMR 60C	60.182	60.228	60	89.965	90	208.7	209.3	92.5	73	91.735	188980	94892

- Notes:** (1) Formula used for effective surface area is  $(\pi * ID * L)/3$ .  
 (2) MAX static load is effective surface area times MAX load for FrelonGOLD®.  
 (3) - 210 kgf/cm<sup>2</sup> is the rating for FrelonGOLD®; 105.45 kgf/cm<sup>2</sup> is the rating for Frelon J.  
 (4) Frelon pads in each end (F dimension).

## MOUNTING DIMENSIONS

Part No.		K	DF	T	Dp	X	Y	Z	Clamping	Concentricity	Squareness	CFPM Weight Kg.	CFPMR Weight Kg.
Square	Round	Square MAX	O.D. MAX	Length MAX	Bolt Circle	Hole	C'Bore Depth	C'Bore Depth	Bolt				
CFPM 08	CFPMR 08	25	32	8	24	3.5	6	3.1	M 3	0.015	0.015	0.027	0.031
CFPM 12	CFPMR 12	32	42	9	32	4.5	7.5	4.1	M 4	0.015	0.015	0.058	0.067
CFPM 16	CFPMR 16	35	46	9	36	4.5	7.5	4.1	M 4	0.015	0.015	0.077	0.088
CFPM 20	CFPMR 20	42	54	11	43	5.5	9	5.1	M 5	0.017	0.017	0.133	0.149
CFPM 25	CFPMR 25	50	62	11	51	5.5	9	5.1	M 5	0.017	0.017	0.270	0.286
CFPM 30	CFPMR 30	60	76	14	62	6.6	11	6.1	M 6	0.017	0.017	0.413	0.450
CFPM 40	CFPMR 40	75	98	18	80	9.0	14	8.1	M 8	0.020	0.020	0.846	0.942
CFPM 50	CFPMR 50	88	112	18	94	9.0	14	8.1	M 8	0.020	0.020	1.450	1.556
CFPM 60	CFPMR 60	106	134	24	112	11.0	17	11.1	M 10	0.025	0.025	2.329	2.519



**Only certified Simplicity 60 Plus Shafting provides maximum linear bearing performance.**

**Inch Series—page 52 Metric Series—page 90**

# Simplicity® Die Set Bushings

## Die Set Bushings PACM

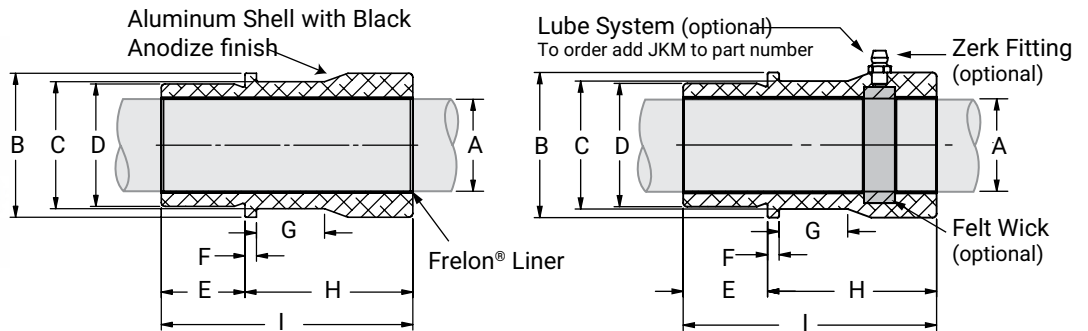

### DIMENSIONAL INFORMATION

P = Precision C = Compensated	Part No.	Nominal Size mm	A Bearing I.D.		B Flange & Barrel O.D. H7		C Clamp Dia.	D Pilot O.D. H7	E Pilot Length	F Flange Length	G Recess Length	H Head Length	I Overall Length	Effective Surface Area CM <sup>2</sup>	MAX Static Load N		Bearing Weight Kg.
			MIN	MAX	MIN	MAX	MIN	MIN	MAX	GOLD	J & W						
P	PACMZ19	19	19.020	19.053	33.975	34	29	27.979	28	18	18	52	70	13.928	28694	14411	0.282
C	PACMZ19C	19	19.096	19.129	33.975	34	29	27.979	28	18	18	52	70	13.928	28694	14411	0.282
P	PACMZ25	25	25.020	25.053	43.975	44	39	37.975	38	23	20	57	80	20.944	43144	21670	0.551
C	PACMZ25C	25	25.096	25.129	43.975	44	39	37.975	38	23	20	57	80	20.944	43144	21670	0.551
P	PACMZ32	32	32.020	32.053	52.970	53	48	44.975	45	26	20	64	90	30.159	62127	31196	0.834
C	PACMZ32C	32	32.096	32.129	52.970	53	48	44.975	45	26	20	64	90	30.159	62127	31196	0.834
P	PACMZ40	40	40.025	40.064	62.970	63	58	53.970	54	30	5	25	70	41.888	86289	43331	1.229
C	PACMZ40C	40	40.127	40.166	62.970	63	58	53.970	54	30	5	25	70	41.888	86289	43331	1.229
P	PACMZ50	50	50.025	50.064	78.970	79	74	64.970	65	35	25	75	110	57.596	118652	59576	2.055
C	PACMZ50C	50	50.127	50.166	78.970	79	74	64.970	65	35	25	75	110	57.596	118652	59576	2.055
P	PACMZ63	63	63.030	63.076	91.965	92	87	80.970	81	48	25	82	130	85.765	106056	88722	2.984
C	PACMZ63C	63	63.182	63.228	91.965	92	87	80.970	81	48	25	82	130	85.765	106056	88722	2.984
P	PACMZ80	80	80.030	80.076	110.965	111	106	99.965	100	48	25	102	150	125.664	258876	129992	4.772
C	PACMZ80C	80	80.182	80.228	110.965	111	106	99.965	100	48	25	102	150	125.664	258876	129992	4.772

- Notes: (1) Formula used for effective surface area is  $(\pi * ID * L)/3$ .  
 (2) Shell material is aluminum..  
 (3) For lubrication system add JKM, example: PACMZ750JKM.  
 (4) MAX static load is effective surface area times max load for FrelonGOLD®.  
 (5) - 210 kgf/cm<sup>2</sup> is the rating for FrelonGOLD;  
 105.45 kgf/cm<sup>2</sup> is the rating for Frelon J.



**Only certified Simplicity 60 Plus Shafting provides maximum linear bearing performance.**

**Inch Series—page 42 Metric Series—page 80**

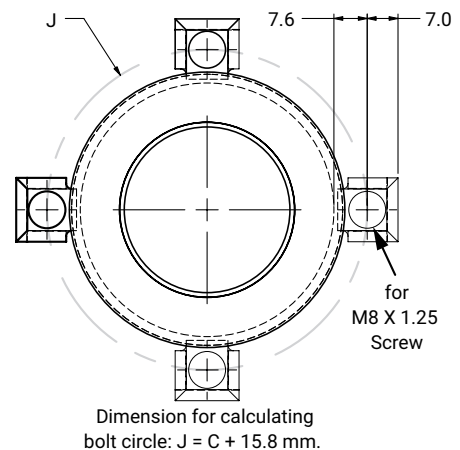
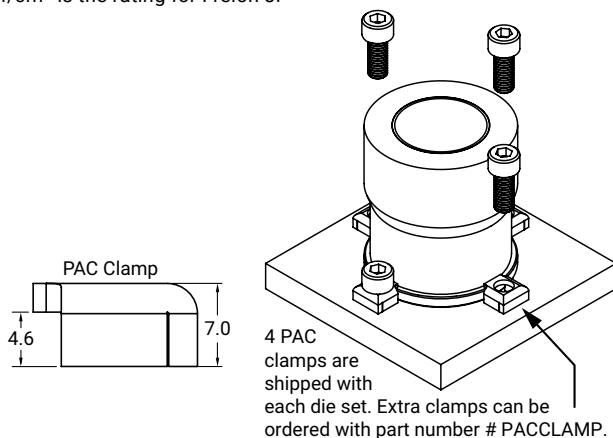

# Simplicity® Sleeve Bearings

## Sleeve Bearings PSM

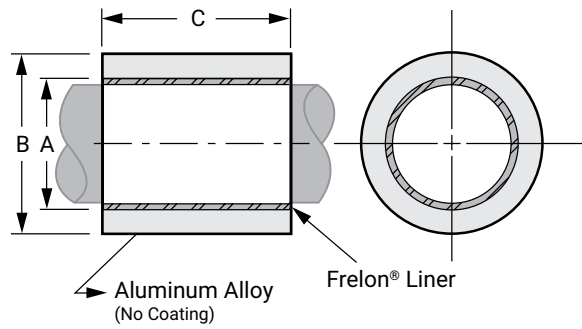
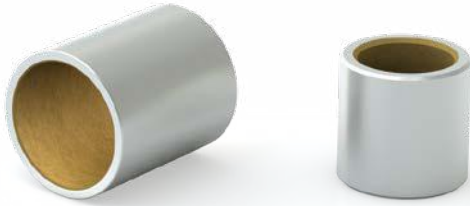

### DIMENSIONAL INFORMATION

Part No.	Nominal Bearing Size			A Bearing I.D.		B O.D. S7		C Length		Max Static Load Kg.		MAX Static Load N		Bearing Weight Kg	Recommended Housing Bore			
	I.D.	O.D.	Length	MIN	MAX	MIN	MAX	MIN	MAX	Frelon®		Frelon			Slip Fit & Epoxy		Press Fit	
										GOLD	J & W	GOLD	J & W		MIN.	MAX	MIN	MAX
PSM0610-06	6	10	6	6.028	6.058	10.023	10.038	5.75	6	76	38	745	373	0.00084	10.038	10.063	10.000	10.015
PSM0610-10	6	10	10	6.028	6.058	10.023	10.038	9.75	10	126	63	1236	618	0.00140	10.038	10.063	10.000	10.015
PSM0812-08	8	12	8	8.033	8.066	12.028	12.046	7.75	8	134	67	1314	657	0.00140	12.046	12.071	12.000	12.018
PSM0812-12	8	12	12	8.033	8.066	12.028	12.046	11.75	12	202	101	1981	990	0.00210	12.046	12.071	12.000	12.018
PSM0814-08	8	14	8	8.033	8.066	14.028	14.046	7.75	8	134	67	1314	657	0.00231	14.046	14.071	14.000	14.018
PSM0814-12	8	14	12	8.033	8.066	14.028	14.046	11.75	12	202	101	1981	990	0.00347	14.046	14.071	14.000	14.018
PSM1014-10	10	14	10	10.033	10.066	14.028	14.046	9.75	10	210	105	2059	1030	0.00210	14.046	14.071	14.000	14.018
PSM1014-16	10	14	16	10.033	10.066	14.028	14.046	15.75	16	336	168	3295	1647	0.00336	14.046	14.071	14.000	14.018
PSM1216-12	12	16	12	12.034	12.070	16.028	16.046	11.75	12	302	151	2961	1481	0.00294	16.046	16.071	16.000	16.018
PSM1216-16	12	16	16	12.034	12.070	16.028	16.046	15.75	16	404	202	3962	1981	0.00392	16.046	16.071	16.000	16.018
PSM1519-16	15	19	16	15.034	15.070	19.035	19.056	15.75	16	504	252	4942	2471	0.00476	19.046	19.071	19.000	19.018
PSM1620-12	16	20	12	16.041	16.080	20.035	20.056	11.50	12	404	202	3962	1981	0.00378	20.056	20.081	20.000	20.021
PSM1620-16	16	20	16	16.041	16.080	20.035	20.056	15.50	16	538	269	5276	2638	0.00505	20.056	20.081	20.000	20.021
PSM1620-25	16	20	25	16.041	16.080	20.035	20.056	24.50	25	840	420	8237	4119	0.00788	20.056	20.081	20.000	20.021
PSM2025-16	20	25	16	20.042	20.084	25.034	25.057	15.50	16	672	336	6590	3295	0.00787	20.056	25.081	25.000	25.021
PSM2025-20	20	25	20	20.042	20.084	25.034	25.057	19.50	20	840	420	8237	4119	0.00984	20.056	25.081	25.000	25.021
PSM2025-25	20	25	25	20.042	20.084	25.034	25.057	24.50	25	1050	525	10296	5148	0.01230	20.056	25.081	25.000	25.021
PSM2025-30	20	25	30	20.042	20.084	25.034	25.057	29.50	30	1260	630	12356	6178	0.01476	20.056	25.081	25.000	25.021
PSM2530-20	25	30	20	25.042	25.084	30.035	30.056	19.50	20	1050	525	10296	5148	0.01202	30.056	30.081	30.000	30.021
PSM2530-25	25	30	25	25.042	25.084	30.035	30.056	24.50	25	1312	656	12865	6433	0.01503	30.056	30.081	30.000	30.021
PSM2530-30	25	30	30	25.042	25.084	30.035	30.056	29.50	30	1576	788	15454	7727	0.01803	30.056	30.081	30.000	30.021
PSM2535-25	25	35	25	25.042	25.084	35.043	35.068	24.50	25	1312	656	12865	6433	0.03276	35.068	35.093	35.000	35.021
PSM2535-35	25	35	35	25.042	25.084	35.043	35.068	34.50	35	1838	919	18023	9012	0.04586	35.068	35.093	35.000	35.021
PSM3035-25	30	35	25	30.050	30.096	35.043	35.068	24.50	25	1576	788	15454	7727	0.01777	35.068	35.093	35.000	35.021
PSM3035-30	30	35	30	30.050	30.096	35.043	35.068	29.50	30	1890	945	18533	9267	0.02133	35.068	35.093	35.000	35.021
PSM3040-35	30	40	35	30.050	30.096	40.043	40.068	34.50	35	2206	1103	21632	10816	0.05349	40.068	40.093	40.000	40.025
PSM3040-50	30	40	50	30.050	30.096	40.043	40.068	49.50	50	3150	1575	30889	15444	0.07641	40.068	40.093	40.000	40.025
PSM3545-25	35	45	25	35.052	35.102	45.041	45.067	24.50	25	1838	919	18023	9012	0.04365	45.068	45.093	45.000	45.025
PSM3545-40	35	45	40	35.052	35.102	45.041	45.067	39.50	40	2940	1470	28830	14415	0.06983	45.068	45.093	45.000	45.025
PSM3545-50	35	45	50	35.052	35.102	45.041	45.067	49.50	50	3676	1838	36047	18023	0.08729	45.068	45.093	45.000	45.025
PSM4050-30	40	50	30	40.052	40.102	50.043	50.068	29.50	30	2520	1260	24711	12356	0.05891	50.068	50.093	50.000	50.025
PSM4050-40	40	50	40	40.052	40.102	50.043	50.068	39.50	40	3360	1680	32948	16474	0.07855	50.068	50.093	50.000	50.025
PSM5060-35	50	60	35	50.062	50.133	60.053	60.099	34.50	35	3676	1838	36047	18023	0.08419	60.099	60.124	60.000	60.030
PSM5060-50	50	60	50	50.062	50.133	60.053	60.099	49.50	50	5250	2625	51482	25741	0.12027	60.099	60.124	60.000	60.030
PSM6070-60	60	70	60	60.063	60.139	70.053	70.099	59.50	60	7560	3780	74133	37067	0.17052	70.099	70.124	70.000	70.030



Consult Factory • 800-962-8979



Email an Application Engineer

# Simplicity® Sleeve Bearings with Flange

## Sleeve Bearings with Flange PSFM

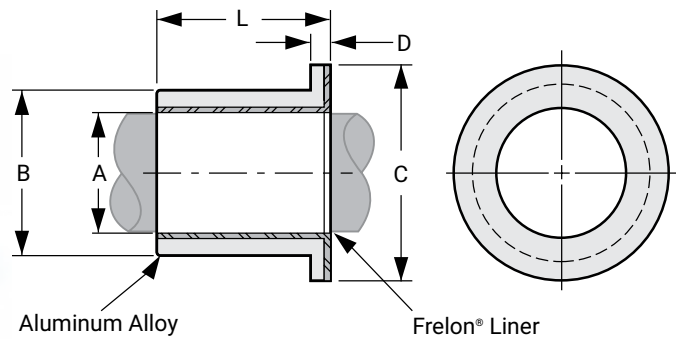

### DIMENSIONAL INFORMATION

Part No.	Nominal Bearing Size mm			A Bearing I.D.		B O.D. S7		C Flange O.D.	D Flange Width	L Length		MAX Static Load Kg.		MAX Static Load N		Bearing Weight Kg	Recommended Housing Bore			
	I.D.	O.D.	Length	MIN	MAX	MIN	MAX			MIN	MAX	GOLD	J & W	GOLD	J & W		Slip Fit & Epoxy		Press Fit	
PSFM0610-06	6	10	6	6.028	6.058	10.023	10.038	14	2	5.75	6	76	38	745	373	0.00126	10.038	10.063	10.00	10.015
PSFM0610-10	6	10	10	6.028	6.058	10.023	10.038	14	2	9.75	10	126	63	1236	618	0.00182	10.038	10.063	10.00	10.015
PSFM0812-06	8	12	6	8.033	8.066	12.028	12.046	16	2	5.75	6	100	50	981	490	0.00153	12.046	12.071	12.00	12.018
PSFM0812-08	8	12	8	8.033	8.066	12.028	12.046	16	2	7.75	8	134	67	1314	657	0.00189	12.046	12.071	12.00	12.018
PSFM0812-12	8	12	12	8.033	8.066	12.028	12.046	16	2	11.75	12	202	101	1981	990	0.00259	12.046	12.071	12.00	12.018
PSFM1016-08	10	16	8	10.033	10.066	16.028	16.046	22	3	7.75	8	168	84	1647	824	0.00421	16.046	16.071	16.00	16.018
PSFM1016-10	10	16	10	10.033	10.066	16.028	16.046	22	3	9.75	10	210	105	2059	1030	0.00489	16.046	16.071	16.00	16.018
PSFM1016-16	10	16	16	10.033	10.066	16.028	16.046	22	3	15.75	16	336	168	3295	1647	0.00694	16.046	16.071	16.00	16.018
PSFM1218-08	12	18	8	12.034	12.070	18.028	18.046	24	3	7.75	8	202	101	1981	990	0.00478	18.046	18.071	18.00	18.018
PSFM1218-12	12	18	12	12.034	12.070	18.028	18.046	24	3	11.75	12	302	151	2961	1481	0.00636	18.046	18.071	18.00	18.018
PSFM1519-16	15	19	16	15.034	15.070	19.028	19.046	25	3	15.50	16	504	252	4942	2471	0.00647	19.046	19.071	19.00	19.018
PSFM1620-16	16	20	16	16.041	16.080	20.035	20.056	27	3	15.55	16	538	269	5276	2638	0.00718	20.056	20.081	20.00	20.021
PSFM1620-20	16	20	20	16.041	16.080	20.035	20.056	27	3	19.50	20	672	336	6590	3295	0.00844	20.056	20.081	20.00	20.021
PSFM1620-25	16	20	25	16.041	16.080	20.035	20.056	27	3	24.50	25	840	420	8237	4119	0.01002	20.056	20.081	20.00	20.021
PSFM2026-20	20	26	20	20.042	20.084	26.035	26.056	32	3	19.50	20	840	420	8237	4119	0.01432	26.056	26.081	26.00	26.021
PSFM2026-30	20	26	30	20.042	20.084	26.035	26.056	32	3	29.50	30	1260	630	12356	6178	0.02035	26.056	26.081	26.00	26.021
PSFM2530-20	25	30	20	25.042	25.084	30.035	30.056	39	3.5	19.50	20	1050	525	10296	5148	0.01672	30.056	30.081	30.00	30.021
PSFM2530-25	25	30	25	25.042	25.084	30.035	30.056	39	3.5	24.50	25	1312	656	12865	6433	0.01973	30.056	30.081	30.00	30.021
PSFM2530-32	25	30	32	25.042	25.084	30.035	30.056	39	3.5	31.50	32	1680	840	16474	8237	0.02394	30.056	30.081	30.00	30.021
PSFM3038-30	30	38	30	30.050	30.096	38.043	38.068	46	4	29.50	30	1890	945	18533	9267	0.04145	38.068	38.093	38.00	38.021
PSFM3545-35	35	45	35	35.052	35.102	45.043	45.068	55	5	34.50	35	2572	1286	25221	12611	0.07192	45.068	45.093	45.00	45.025
PSFM4050-40	40	50	40	40.052	40.102	50.043	50.068	60	5	39.50	40	3360	1680	32948	16474	0.09044	50.068	50.093	50.00	50.025
PSFM5060-50	50	60	50	50.062	50.133	60.053	60.099	70	5	49.50	50	5250	2625	51482	25741	0.13429	60.099	60.124	60.00	60.030

### ORDERING INFORMATION

PSM	16	20	16
Type	I.D.	O.D.	Length
PSM: Precision Sleeve Bearing	I.D. in mm	O.D. in mm	Length in mm
PSFM: Precision Sleeve Bearing with Flange	I.D. in mm	O.D. in mm	Length in mm

Note: Lengths not listed above must be specially quoted.



Only certified Simplicity 60 Plus Shafting provides maximum linear bearing performance.

Inch Series—page 52 Metric Series—page 90

### INSTALLATION INSTRUCTIONS

1. Slip the bearing sleeve into the housing and epoxy into place with Loctite® or similar type bonding agent.

**CAUTION** Do NOT let any of the adhesive touch the bearing liner. It will harden and interfere with the running clearance.

2. Freeze the bearings at 0°F (-17.75°C) for 30-45 minutes. Using gloves, remove the bearings from the freezer and slip them into the housing. As they heat to room temperature, full contact between the bearing and housing will be achieved. The greatest advantage to this technique over traditional pressing is greater accuracy in alignment.

# Linear Ball Bearings Precision Plus Self Aligning

## Self Aligning Ball Bearings EPS & EPS\_OP

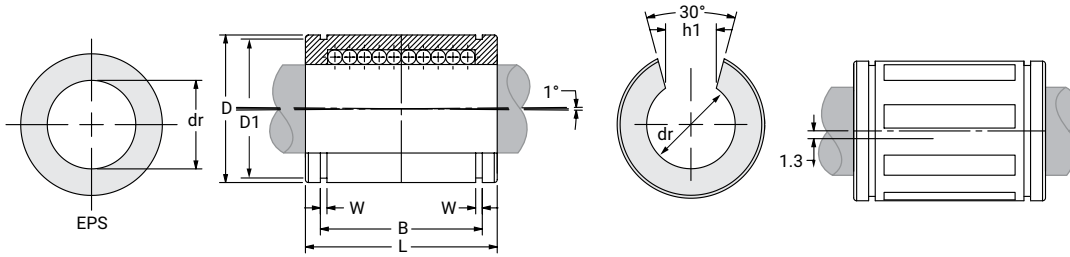

EPS – Self Aligning Closed

EPSxx-OP – Self Aligning Open



### DIMENSIONAL INFORMATION

Part No. Self Aligning Closed	Nominal Diameter			Ball Circuit	Weight G	Major Dimensions & Tolerances						Load Ratings		
	Size mm	dr mm	Tolerance mm			D mm	L mm	Tolerance mm	B mm	Tolerance mm	W mm	D1 mm	Dynamic C N	Static Co N
EPS16	16	16	0/-0.013	5	26	26	36	0/-0.51	24.6	0/-0.51	1.30	24.9	1140	710
EPS20	20	20	0/-0.013	6	60	32	45	0/-0.51	31.2	0/-0.51	1.60	30.5	2280	1400
EPS25	25	25	0/-0.013	6	120	40	58	0/-0.51	43.7	0/-0.51	1.85	38.5	3800	2740
EPS30	30	30	0/-0.013	6	184	47	68	0/-0.64	51.7	0/-0.64	1.85	44.5	4710	2800
EPS40	40	40	0/-0.013	6	342	62	80	0/-0.76	60.3	0/-0.76	2.15	58.5	6500	5460
EPS50	50	50	0/-0.013	6	586	75	100	0/-1.02	77.3	0/-1.02	2.65	71.5	11460	7940

Part No. Self Aligning Open	Nominal Diameter			Ball Circuit	Weight G	Major Dimensions & Tolerances						Load Ratings				
	Size mm	dr mm	Tolerance mm			D mm	L mm	Tolerance mm	B mm	Tolerance mm	W mm	D1 mm	H1 mm	J mm	Dynamic C N	Static Co N
EPS16-OP	16	16	0/-0.013	4	20	26	36	0/-0.51	24.6	0/-0.51	1.30	24.9	9.0	through	1330	910
EPS20-OP	20	20	0/-0.013	5	50	32	45	0/-0.51	31.2	0/-0.51	1.60	30.5	9.0	0.039	2310	1445
EPS25-OP	25	25	0/-0.013	5	100	40	58	0/-0.51	43.7	0/-0.51	1.85	38.5	11.5	0.059	3910	2820
EPS30-OP	30	30	0/-0.013	5	154	47	68	0/-0.64	51.7	0/-0.64	1.85	44.5	14.0	0.047	4850	2900
EPS40-OP	40	40	0/-0.013	5	286	62	80	0/-0.76	60.3	0/-0.76	2.15	58.5	19.5	0.090	6700	5625
EPS50-OP	50	50	0/-0.013	5	486	75	100	0/-1.02	77.3	0/-1.02	2.65	71.5	22.5	0.090	11700	8100

# Linear Ball Bearings Precision

## Ball Bearings EP

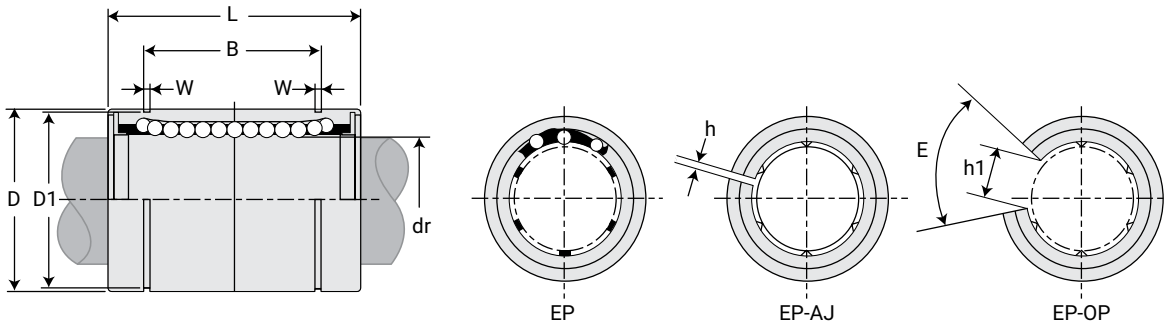

EP – Standard Closed



EPxx-AJ – Adjustable



EPxx-OP – Standard Open



## DIMENSIONAL INFORMATION

(Standard Steel Finish)

Part No.			Nominal Diameter			Ball Circuit	Weight	Major Dimensions & Tolerances					
Standard Closed	Adjustable	Standard Open	Size mm	dr mm	Tolerance mm			D mm	Tolerance mm	L mm	Tolerance mm	B mm	Tolerance mm
EP05G	-	-	5	5	+0.008/0	4	11	12	0/-0.008	22	0/-0.2	14.5	0/-0.2
EP08G	-	-	8	8	+0.008/0	4	20	16	0/-0.008	25	0/-0.2	16.5	0/-0.2
EP10G	-	-	10	10	+0.008/0	4	36	19	0/-0.009	29	0/-0.2	22	0/-0.2
EP12G	EP12G-AJ	EP12G-OP	12	12	+0.008/0	5	41	22	0/-0.009	32	0/-0.2	22.9	0/-0.2
EP16G	EP16G-AJ	EP16G-OP	16	16	+0.009/-0.001	5	65	26	0/-0.009	36	0/-0.2	24.9	0/-0.2
EP20G	EP20G-AJ	EP20G-OP	20	20	+0.009/-0.001	5	91	32	0/-0.011	45	0/-0.2	31.5	0/-0.2
EP25G	EP25G-AJ	EP25G-OP	25	25	+0.011/-0.001	6	215	40	0/-0.011	58	0/-0.3	44.1	0/-0.3
EP30G	EP30G-AJ	EP30G-OP	30	30	+0.011/-0.001	6	325	47	0/-0.011	68	0/-0.3	52.1	0/-0.3
EP40G	EP40G-AJ	EP40G-OP	40	40	+0.013/-0.002	6	705	62	0/-0.013	80	0/-0.3	60.6	0/-0.3
EP50G	EP50G-AJ	EP50G-OP	50	50	+0.013/-0.002	6	1130	75	0/-0.013	100	0/-0.3	77.6	0/-0.3

Part No.			Nominal Diameter			Major Dimensions & Tolerances							Load Ratings	
Standard Closed	Adjustable	Standard Open	Size mm	dr mm	Tolerance mm	W mm	D1 mm	H mm	H1 mm	E Slot Angle	MAX Eccentricity μm	MAX Radial Clearance μm	Dynamic C N	Static Co N
EP05G	-	-	5	5	+0.008/0	1.1	11.5	-	-	-	12	-5	200	260
EP08G	-	-	8	8	+0.008/0	1.1	15.2	-	-	-	12	-5	260	400
EP10G	-	-	10	10	+0.008/0	1.3	18	-	-	-	12	-5	372	549
EP12G	EP12G-AJ	EP12G-OP	12	12	+0.008/0	1.3	21	1.5	7.5	78°	12	-7	410	590
EP16G	EP16G-AJ	EP16G-OP	16	16	+0.009/-0.001	1.3	24.9	1.5	10	78°	12	-7	770	1170
EP20G	EP20G-AJ	EP20G-OP	20	20	+0.009/-0.001	1.6	30.3	2	10	60°	15	-9	860	1370
EP25G	EP25G-AJ	EP25G-OP	25	25	+0.011/-0.001	1.85	37.5	2	12.5	60°	15	-9	980	1560
EP30G	EP30G-AJ	EP30G-OP	30	30	+0.011/-0.001	1.85	44.5	2	12.5	50°	15	-9	1560	2740
EP40G	EP40G-AJ	EP40G-OP	40	40	+0.013/-0.002	2.15	59	3	16.8	50°	17	-13	2150	4010
EP50G	EP50G-AJ	EP50G-OP	50	50	+0.013/-0.002	2.65	72	3	21	50°	17	-13	3820	7930

# Linear Ball Bearings Double Wide

## Double Wide Ball Bearings EP-W

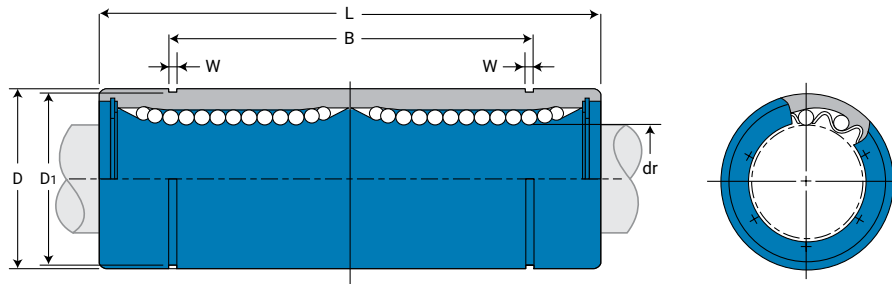

### DIMENSIONAL INFORMATION

(Standard Steel Finish)

Part No.	Nominal Diameter			Ball Circuit	Weight G	Major Dimensions & Tolerances					
	Size mm	dr mm	Tolerance mm			D mm	Tolerance mm	L mm	Tolerance mm	B mm	Tolerance mm
EP08GW	8	8	+0.009/-0.001	4	40	16	0/-0.009	45	0/-0.3	33	0/-0.3
EP12GW	12	12	+0.009/-0.001	4	80	22	0/-0.011	61	0/-0.3	45.8	0/-0.3
EP16GW	16	16	+0.011/-0.001	5	115	26	0/-0.011	68	0/-0.3	49.8	0/-0.3
EP20GW	20	20	+0.011/-0.001	5	180	32	0/-0.013	80	0/-0.3	61	0/-0.3
EP25GW	25	25	+0.013/-0.002	6	430	40	0/-0.013	112	0/-0.4	82	0/-0.4
EP30GW	30	30	+0.013/-0.002	6	615	47	0/-0.013	123	0/-0.4	104.2	0/-0.4
EP40GW	40	40	+0.016/-0.004	6	1400	62	0/-0.015	151	0/-0.4	121.2	0/-0.4
EP50GW	50	50	+0.016/-0.004	6	2320	75	0/-0.020	192	0/-0.4	155.2	0/-0.4

Part No.	Nominal Diameter			Major Dimensions & Tolerances			Load Ratings	
	Size mm	dr mm	Tolerance mm	W mm	D1 mm	MAX Eccentricity μm	Dynamic C N	Static Co N
EP08GW	8	8	+0.009/-0.001	1.1	15.2	15	421	804
EP12GW	12	12	+0.009/-0.001	1.3	21	15	813	1570
EP16GW	16	16	+0.011/-0.001	1.3	24.9	15	921	1780
EP20GW	20	20	+0.011/-0.001	1.6	30.3	17	1370	2740
EP25GW	25	25	+0.013/-0.002	1.85	38	17	1570	3140
EP30GW	30	30	+0.013/-0.002	1.85	44.5	17	2500	5490
EP40GW	40	40	+0.016/-0.004	2.15	59	20	3430	8040
EP50GW	50	50	+0.016/-0.004	2.65	72	20	6080	15900



Only certified Simplicity 60 Plus Shafting provides maximum linear bearing performance.

Inch Series—page 52 Metric Series—page 90

# Linear Ball Bearings Pillow Blocks

## Ball Bearings – Closed Pillow Blocks EPPM

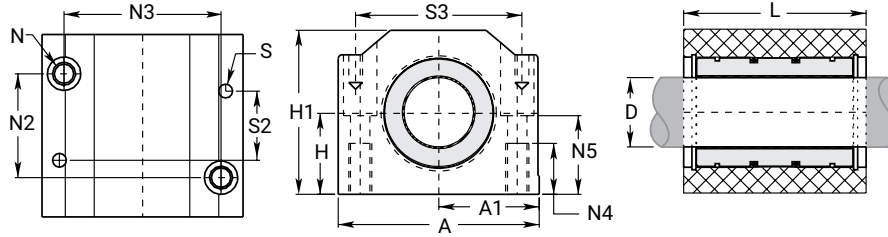

Part No.	D Nom. Brg. I.D.	H Centerline +/- 0.015	H1 Height	A Width	A1 Centerline +/- 0.013	L Length	N Bolt								Load Ratings		
								N2	N3	N4	N5	S	S2	S3	Assem. WT. Kg.	Dynamic C N	Static Co N
EPPM08G	8	15	28	35	17.5	32	M4 x 0.7	20	25	9	14.5	N/A	N/A	N/A	0.069	260	400
EPPM10G	10	16	31.5	40	20	36	M5 x 0.8	20	29	11	15	4	29	31	0.095	372	549
EPPM12G	12	18	35	43	21.5	39	M5 x 0.8	23	32	11	16.5	4	32	34	0.118	410	590
EPPM16G	16	22	42	53	26.5	43	M6 x 1.0	26	40	13	21	4	35	42	0.200	770	1170
EPPM20G	20	25	50	60	30	54	M8 x 1.25	32	45	18	24	5	45	50	0.329	860	1370
EPPM25G	25	30	60	78	39	67	M10 x 1.5	40	60	22	29	6	20	64	0.655	980	1560
EPPM30G	30	35	71	87	43.5	79	M10 x 1.5	45	68	22	34	6	30	72	1.020	1560	2740
EPPM40G	40	45	91	108	54	91	M12 x 1.75	58	86	26	44	8	35	90	1.846	2150	4010
EPPM50G	50	50	105	132	66	113	M16 x 2.0	50	105	34	49	10	42	108	3.169	3820	7930

- Notes:** (1) Standard pillow block assembly includes self-aligning housing.  
 (2) All standard metric pillow blocks use standard EP series bearings.  
 (3) Straight bore pillow block assembly includes standard EP series bearing in straight bore housing.

## Ball Bearings – Open Pillow Blocks EPPMN

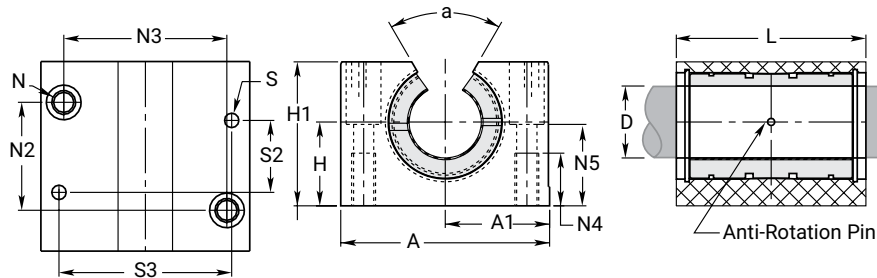

Part No.	D Nom. BRG. I.D.	H Centerline +/- 0.015	H1 Height	A Width	A1 Centerline +/- 0.013	L Length	N Bolt								Load Ratings			
								N2	N3	N4	N5	S	S2	S3	A	Assem. WT. Kg.	Dynamic C N	Static Co N
EPPMN12G	12	18	28	43	21.5	39	M5 x 0.8	23	32	11	16.5	4	32	34	66	0.096	410	590
EPPMN16G	16	22	35	53	26.5	43	M6 x 1.0	26	40	13	21	4	35	42	68	0.162	770	1170
EPPMN20G	20	25	42	60	30	54	M8 x 1.25	32	45	18	24	5	45	50	60	0.267	860	1370
EPPMN25G	25	30	51	78	39	67	M10 x 1.5	40	60	22	29	6	20	64	60	0.536	980	1560
EPPMN30G	30	35	60	87	43.5	79	M10 x 1.5	45	68	22	34	6	30	72	60	0.831	1560	2740
EPPMN40G	40	45	77	108	54	91	M12 x 1.75	58	86	26	44	8	35	90	60	1.499	2150	4010
EPPMN50G	50	50	88	132	66	113	M16 x 2.0	50	105	34	49	10	42	108	60	2.539	3820	7930

- Notes:** (1) Standard pillow block assembly includes self-aligning housing.  
 (2) All standard metric pillow blocks use standard EP series bearings.

INCH

ISO METRIC

JIS METRIC

# Linear Ball Bearings Square Flange Mount

## Ball Bearings – Square Flange Mount EPK

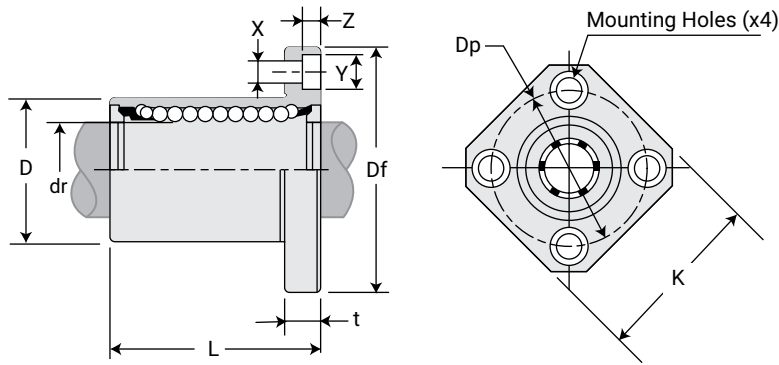

### DIMENSIONAL INFORMATION

(Standard Steel Finish)

Part No. Standard Polymer Cage	Nominal Diameter			Ball Circuit	Weight G	Major Dimensions & Tolerances			
	Size mm	dr mm	Tolerance mm			D mm	Tolerance mm	L mm	Tolerance mm
EPK08G	8	8	+0.008/0	4	41	16	0/-0.013	25	±0.3
EPK12G	12	12	+0.008/0	4	80	22	0/-0.016	32	±0.3
EPK16G	16	16	+0.009/-0.001	5	103	26	0/-0.016	36	±0.3
EPK20G	20	20	+0.009/-0.001	5	182	32	0/-0.019	45	±0.3
EPK25G	25	25	+0.011/-0.001	6	335	40	0/-0.019	58	±0.3
EPK30G	30	30	+0.011/-0.001	6	560	47	0/-0.019	68	±0.3
EPK40G	40	40	+0.013/-0.002	6	1175	62	0/-0.022	80	±0.3
EPK50G	50	50	+0.013/-0.002	6	1745	75	0/-0.022	100	±0.3

Part No. Standard Polymer Cage	Nominal Diameter			Major Dimensions & Tolerances – Flange									Load Ratings	
	Size mm	dr mm	Tolerance mm	Df mm	K mm	T mm	DP mm	X mm	Y mm	Z mm	Eccentricity μm	Squareness μm	Dynamic C N	Static Co N
EPK08G	8	8	+0.008/0	32	25	5	24	3.5	6.5	3.1	12	12	265	402
EPK12G	12	12	+0.008/0	42	32	6	32	4.5	8	4.1	12	12	510	784
EPK16G	16	16	+0.009/-0.001	46	35	6	36	4.5	8	4.1	12	12	578	892
EPK20G	20	20	+0.009/-0.001	54	42	8	43	5.5	9.3	5.1	15	15	862	1370
EPK25G	25	25	+0.011/-0.001	62	50	8	51	5.5	9.3	5.1	15	15	980	1570
EPK30G	30	30	+0.011/-0.001	76	60	10	62	6.6	11	6.1	15	15	1570	2740
EPK40G	40	40	+0.013/-0.002	98	75	13	80	9	14	8.1	17	17	2160	4020
EPK50G	50	50	+0.013/-0.002	112	88	13	94	9	14	8.1	17	17	3820	7940



Only certified Simplicity 60 Plus Shafting provides maximum linear bearing performance.

Inch Series—page 52 Metric Series—page 90

# Linear Ball Bearings Round Flange Mount

## Ball Bearings – Round Flange Mount EPF

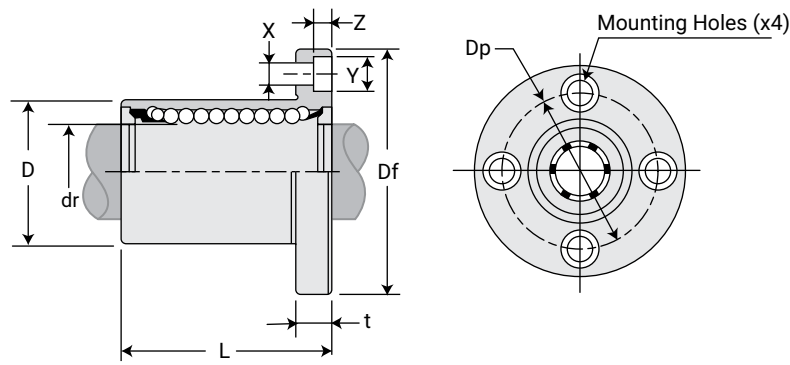

### DIMENSIONAL INFORMATION

(Standard Steel Finish)

Part No.	Nominal Diameter			Ball Circuit	Weight G	Major Dimensions & Tolerances				
	Standard Polymer Cage	Size mm	dr mm			Tolerance mm	D mm	Tolerance mm	L mm	Tolerance mm
EPF08G		8	8	+0.008/0	4	41	16	0/-0.013	25	±0.3
EPF12G		12	12	+0.008/0	4	80	22	0/-0.016	32	±0.3
EPF16G		16	16	+0.009/-0.001	5	103	26	0/-0.016	36	±0.3
EPF20G		20	20	+0.009/-0.001	5	182	32	0/-0.019	45	±0.3
EPF25G		25	25	+0.011/-0.001	6	335	40	0/-0.019	58	±0.3
EPF30G		30	30	+0.011/-0.001	6	560	47	0/-0.019	68	±0.3
EPF40G		40	40	+0.013/-0.002	6	1175	62	0/-0.022	80	±0.3
EPF50G		50	50	+0.013/-0.002	6	1745	75	0/-0.022	100	±0.3

Part No.	Nominal Diameter			Major Dimensions & Tolerances – Flange								Load Ratings		
	Standard Polymer Cage	Size mm	dr mm	Tolerance mm	Df mm	T mm	Dp mm	X mm	Y mm	Z mm	Eccentricity μm	Squareness μm	Dynamic C N	Static Co N
EPF08G		8	8	+0.008/0	32	5	24	3.5	6.5	3.1	12	12	265	402
EPF12G		12	12	+0.008/0	42	6	32	4.5	8	4.1	12	12	510	784
EPF16G		16	16	+0.009/-0.001	46	6	36	4.5	8	4.1	12	12	578	892
EPF20G		20	20	+0.009/-0.001	54	8	43	5.5	9.3	5.1	15	15	862	1370
EPF25G		25	25	+0.011/-0.001	62	8	51	5.5	9.3	5.1	15	15	980	1570
EPF30G		30	30	+0.011/-0.001	76	10	62	6.6	11	6.1	15	15	1570	2740
EPF40G		40	40	+0.013/-0.002	98	13	80	9	14	8.1	17	17	2160	4020
EPF50G		50	50	+0.013/-0.002	112	13	94	9	14	8.1	17	17	3820	7940



Only certified Simplicity 60 Plus Shafting provides maximum linear bearing performance.

Inch Series–page 52 Metric Series–page 90

# Linear Ball Bearings Double Wide

## Double Wide Ball Bearings – Square Flange Mount EPK-W

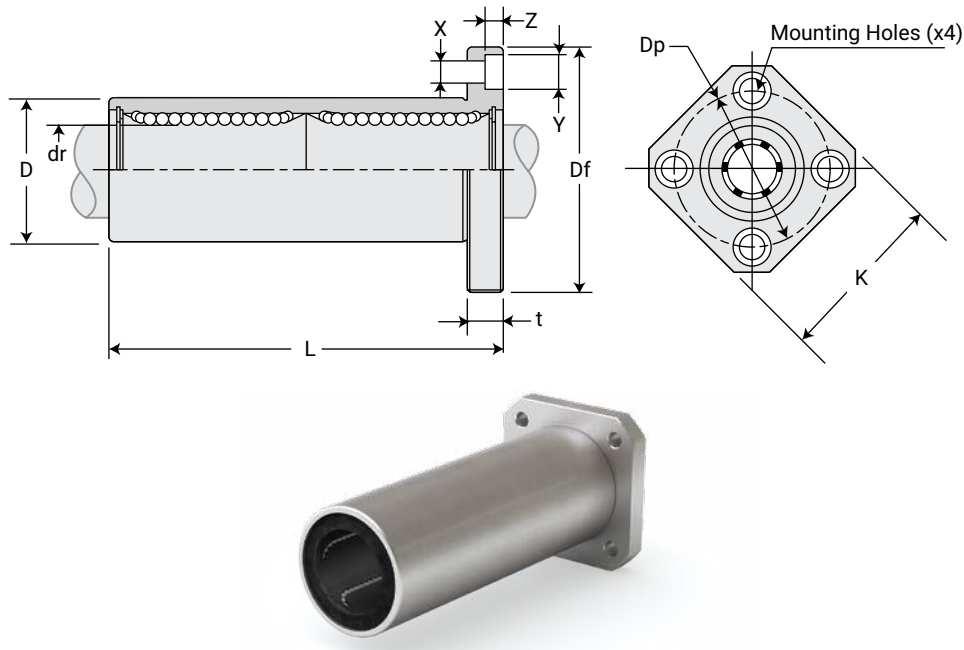

### DIMENSIONAL INFORMATION

(Standard Steel Finish)

Part No.	Nominal Diameter			Ball Circuit	Weight G	Major Dimensions & Tolerances				
	Standard Polymer Cage	Size mm	dr mm			Tolerance mm	D mm	Tolerance mm	L mm	Tolerance mm
EPK08GW		8	8	+0.009/-0.001	4	51	16	0/-0.013	45	±0.3
EPK12GW		12	12	+0.009/-0.001	4	90	22	0/-0.016	61	±0.3
EPK16GW		16	16	+0.011/-0.001	5	135	26	0/-0.016	70	±0.3
EPK20GW		20	20	+0.011/-0.001	5	225	32	0/-0.019	80	±0.3
EPK25GW		25	25	+0.013/-0.002	6	500	40	0/-0.019	112	±0.3
EPK30GW		30	30	+0.013/-0.002	6	720	47	0/-0.019	123	±0.3
EPK40GW		40	40	+0.016/-0.004	6	1600	62	0/-0.022	154	±0.3
EPK50GW		50	50	+0.016/-0.004	6	2620	75	0/-0.022	192	±0.3

Part No.	Nominal Diameter			Major Dimensions & Tolerances – Flange									Load Ratings		
	Standard Polymer Cage	Size mm	dr mm	Tolerance mm	Df mm	K mm	T mm	Dp mm	X mm	Y mm	Z mm	Eccentricity μm	Squareness μm	Dynamic C N	Static Co N
EPK08GW		8	8	+0.009/-0.001	32	25	5	24	3.5	6.5	3.1	15	15	421	804
EPK12GW		12	12	+0.009/-0.001	42	32	6	32	4.5	8	4.1	15	15	813	1570
EPK16GW		16	16	+0.011/-0.001	46	35	6	36	4.5	8	4.1	15	15	921	1780
EPK20GW		20	20	+0.011/-0.001	54	42	8	43	5.5	9.3	5.1	17	17	1370	2740
EPK25GW		25	25	+0.013/-0.002	62	50	8	51	5.5	9.3	5.1	17	17	1570	3140
EPK30GW		30	30	+0.013/-0.002	76	60	10	62	6.6	11	6.1	17	17	2500	5490
EPK40GW		40	40	+0.016/-0.004	98	75	13	80	9	14	8.1	20	20	3430	8040
EPK50GW		50	50	+0.016/-0.004	112	88	13	94	9	14	8.1	20	20	6080	15900



Only certified Simplicity 60 Plus Shafting provides maximum linear bearing performance.

Inch Series—page 52 Metric Series—page 90

# Linear Ball Bearings Double Wide

## Double Wide Ball Bearings – Round Flange Mount EPF-W

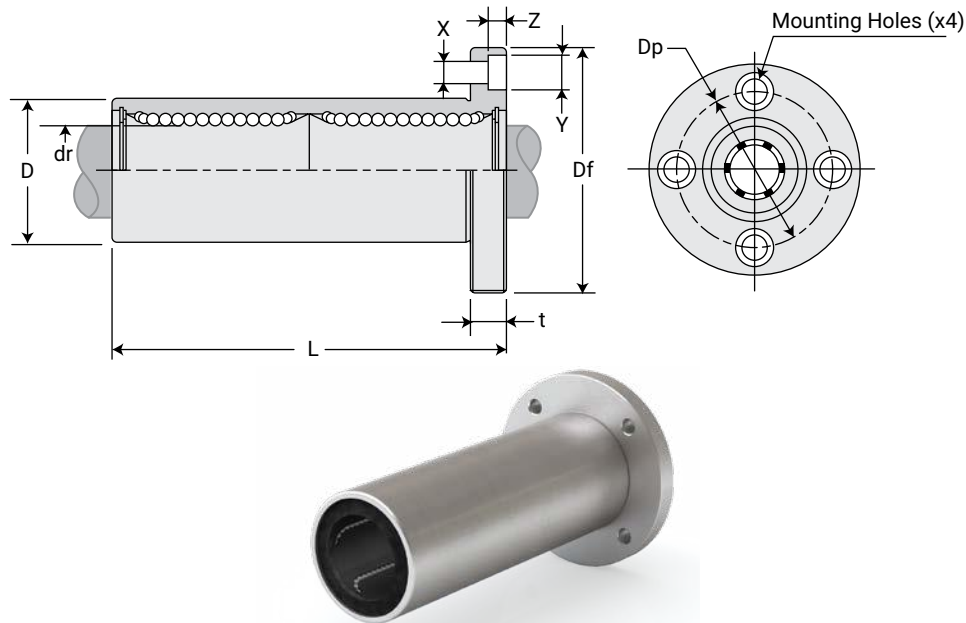

### DIMENSIONAL INFORMATION

(Standard Steel Finish)

Part No.	Nominal Diameter			Ball Circuit	Weight G	Major Dimensions & Tolerances				
	Standard Polymer Cage	Size mm	dr mm			Tolerance mm	D mm	Tolerance mm	L mm	Tolerance mm
EPF08GW		8	8	+0.009/-0.001	4	59	16	0/-0.013	46	±0.3
EPF12GW		12	12	+0.009/-0.001	4	110	22	0/-0.016	61	±0.3
EPF16GW		16	16	+0.011/-0.001	5	160	26	0/-0.016	68	±0.3
EPF20GW		20	20	+0.011/-0.001	5	260	32	0/-0.019	80	±0.3
EPF25GW		25	25	+0.013/-0.002	6	540	40	0/-0.019	112	±0.3
EPF30GW		30	30	+0.013/-0.002	6	815	47	0/-0.019	123	±0.3
EPF40GW		40	40	+0.016/-0.004	6	1805	62	0/-0.022	154	±0.3
EPF50GW		50	50	+0.016/-0.004	6	2820	75	0/-0.022	192	±0.3

Part No.	Nominal Diameter			Major Dimensions & Tolerances – Flange								Load Ratings		
	Standard Polymer Cage	Size mm	dr mm	Tolerance mm	Df mm	T mm	Dp mm	X mm	Y mm	Z mm	Eccentricity μm	Squareness μm	Dynamic C N	Static Co N
EPF08GW		8	8	+0.009/-0.001	32	5	24	3.5	6.5	3.1	15	15	421	804
EPF12GW		12	12	+0.009/-0.001	42	6	32	4.5	8	4.1	15	15	813	1570
EPF16GW		16	16	+0.011/-0.001	46	6	36	4.5	8	4.1	15	15	921	1780
EPF20GW		20	20	+0.011/-0.001	54	8	43	5.5	9.3	5.1	17	17	1370	2740
EPF25GW		25	25	+0.013/-0.002	62	8	51	5.5	9.3	5.1	17	17	1570	3140
EPF30GW		30	30	+0.013/-0.002	76	10	62	6.6	11	6.1	17	17	2500	5490
EPF40GW		40	40	+0.016/-0.004	98	13	80	9	14	8.1	20	20	3430	8040
EPF50GW		50	50	+0.016/-0.004	112	13	94	9	14	8.1	20	20	6080	15900



Only certified Simplicity 60 Plus Shafting provides maximum linear bearing performance.

Inch Series—page 52 Metric Series—page 90

# Linear Ball Bearings Square Flange Center Mount

## Ball Bearings – Square Flange Center Mount EPKC

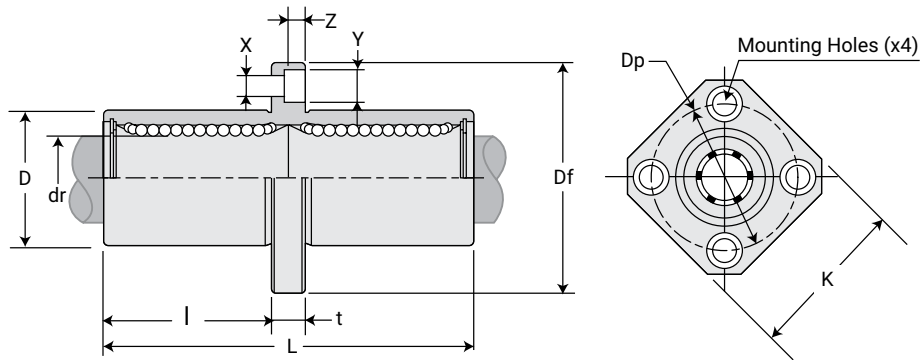

### DIMENSIONAL INFORMATION

(Standard Steel Finish)

Part No.	Nominal Diameter			Ball Circuit	Weight G	Major Dimensions & Tolerances			
	Size mm	dr mm	Tolerance $\mu\text{m}$			D mm	Tolerance $\mu\text{m}$	L mm	Tolerance $\mu\text{m}$
EPKC08G	8	8	+9/-1	4	51	16	0/-13	45	$\pm 300$
EPKC12G	12	12	+9/-1	4	90	22	0/-16	57	$\pm 300$
EPKC16G	16	16	+11/-1	5	135	26	0/-16	70	$\pm 300$
EPKC20G	20	20	+11/-1	5	225	32	0/-19	80	$\pm 300$
EPKC25G	25	25	+13/-2	6	500	40	0/-19	112	$\pm 300$
EPKC30G	30	30	+13/-2	6	720	47	0/-19	123	$\pm 300$
EPKC40G	40	40	+16/-4	6	1600	62	0/-22	154	$\pm 300$
EPKC50G	50	50	+16/-4	6	2620	75	0/-22	192	$\pm 300$

Part No.	Nominal Diameter			Major Dimensions & Tolerances – Flange										Load Ratings	
	Size mm	dr mm	Tolerance $\mu\text{m}$	l mm	Df mm	K mm	T mm	Dp mm	X mm	Y mm	Z mm	Eccentricity $\mu\text{m}$	Squareness $\mu\text{m}$	Dynamic C N	Static Co N
EPKC08G	8	8	+9/-1	20.5	32	25	5	24	3.5	6.5	3.1	15	15	421	804
EPKC12G	12	12	+9/-1	27.5	42	32	6	32	4.5	8	4.1	15	15	813	1570
EPKC16G	16	16	+11/-1	31	46	35	6	36	4.5	8	4.1	15	15	921	1780
EPKC20G	20	20	+11/-1	36	54	42	8	43	5.5	9.3	5.1	17	17	1370	2740
EPKC25G	25	25	+13/-2	52	62	50	8	51	5.5	9.3	5.1	17	17	1570	3140
EPKC30G	30	30	+13/-2	56.5	76	60	10	62	6.6	11	6.1	17	17	2500	5490
EPKC40G	40	40	+16/-4	69	98	75	13	80	9	14	8.1	20	20	3430	8040
EPKC50G	50	50	+16/-4	89.5	112	88	13	94	9	14	8.1	20	20	6080	15900



Only certified Simplicity 60 Plus Shafting provides maximum linear bearing performance.

Inch Series—page 52 Metric Series—page 90

# Linear Ball Bearings Round Flange Center Mount

## Ball Bearings – Round Flange Center Mount EPFC

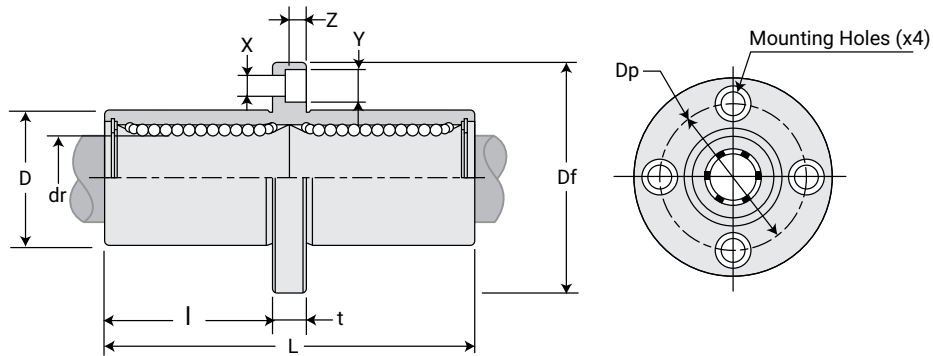

### DIMENSIONAL INFORMATION

(Standard Steel Finish)

Part No.	Nominal Diameter			Ball Circuit	Weight G	Major Dimensions & Tolerances				
	Standard Polymer Cage	Size mm	dr mm			Tolerance $\mu\text{m}$	D mm	Tolerance $\mu\text{m}$	L mm	Tolerance $\mu\text{m}$
EPFC08G		8	8	+9/-1	4	59	16	0/-13	45	$\pm 300$
EPFC12G		12	12	+9/-1	4	110	22	0/-16	61	$\pm 300$
EPFC16G		16	16	+11/-1	5	160	26	0/-16	68	$\pm 300$
EPFC20G		20	20	+11/-1	5	260	32	0/-19	80	$\pm 300$
EPFC25G		25	25	+13/-2	6	540	40	0/-19	112	$\pm 300$
EPFC30G		30	30	+13/-2	6	815	47	0/-19	123	$\pm 300$
EPFC40G		40	40	+16/-4	6	1805	62	0/-22	154	$\pm 300$
EPFC50G		50	50	+16/-4	6	2820	75	0/-22	192	$\pm 300$

Part No.	Nominal Diameter			Major Dimensions & Tolerances – Flange									Load Ratings		
	Standard Polymer Cage	Size mm	dr mm	Tolerance $\mu\text{m}$	I mm	Df mm	T mm	Dp mm	X mm	Y mm	Z mm	Eccentricity $\mu\text{m}$	Squareness $\mu\text{m}$	Dynamic C N	Static Co N
EPFC08G		8	8	+9/-1	20.5	32	5	24	3.5	6.5	3.1	15	15	421	804
EPFC12G		12	12	+9/-1	27.5	42	6	32	4.5	8	4.1	15	15	813	1570
EPFC16G		16	16	+11/-1	31	46	6	36	4.5	8	4.1	15	15	921	1780
EPFC20G		20	20	+11/-1	36	54	8	43	5.5	9.3	5.1	17	17	1370	2740
EPFC25G		25	25	+13/-2	52	62	8	51	5.5	9.3	5.1	17	17	1570	3140
EPFC30G		30	30	+13/-2	56.5	76	10	62	6.6	11	6.1	17	17	2500	5490
EPFC40G		40	40	+16/-4	69	98	13	80	9	14	8.1	20	20	3430	8040
EPFC50G		50	50	+16/-4	89.5	112	13	94	9	14	8.1	20	20	6080	15900



Only certified Simplicity 60 Plus Shafting provides maximum linear bearing performance.

Inch Series—page 52 Metric Series—page 90

# Linear Ball Bearings Compact Thin Wall

## Ball Bearings – Compact Thin Wall KHP

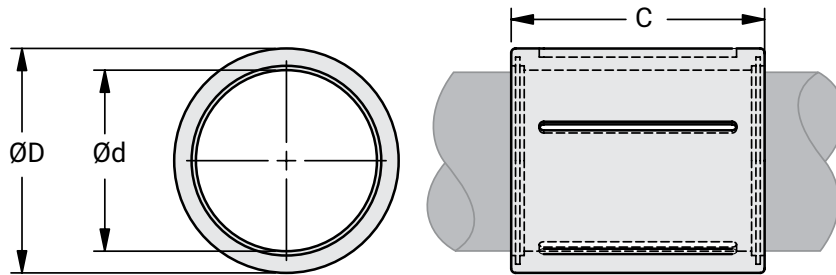

### DIMENSIONAL INFORMATION

(Standard Steel Finish)

Part No.	Dimensions						Load Rating		
	Ød mm	Tolerance µm	ØD mm	Tolerance µm	C mm	Tolerance µm	Weight G	Dynamic C N	Static Co N
KHP06	6	0/+12	12	-11/0	22	-520/0	7	400	239
KHP08	8	0/+15	15	-11/0	24	-520/0	12	435	280
KHP10	10	0/+15	17	-11/0	26	-520/0	14.5	500	370
KHP12	12	0/+18	19	-13/0	28	-520/0	18.5	620	510
KHP14	14	0/+18	21	-13/0	28	-520/0	20.5	620	520
KHP16	16	0/+18	24	-13/0	30	-520/0	27.5	800	620
KHP20	20	0/+21	28	-13/0	30	-520/0	32.5	950	790
KHP25	25	0/+21	35	-16/0	40	-620/0	66	1990	1670
KHP30	30	0/+21	40	-16/0	50	-620/0	95	2880	2700
KHP40	40	0/+25	52	-19/0	60	-740/0	182	4400	4450
KHP50	50	0/+25	62	-19/0	70	-740/0	252	5500	6300



Only certified Simplicity 60 Plus Shafting provides maximum linear bearing performance.

Inch Series—page 52 Metric Series—page 90

# Roller Pillow Blocks Bearings



## Single Roller Pillow Block MSPB-OPN

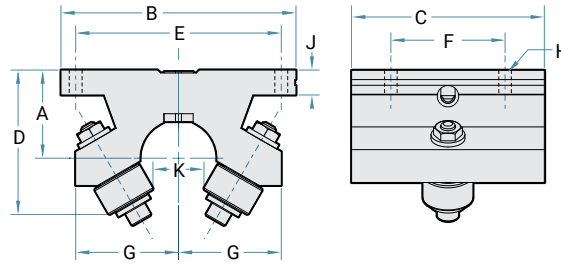

Dimensions and Load Ratings Metric Shafting

Part Number	Shaft Diameter mm	DYN. Load Rating N	Weight g	A	B	C	D	E	F	G	H		J	K
				±0.08 mm	mm	mm	mm	±0.13 mm	±0.13 mm	mm	Bolt	Hole mm	mm	mm
MSPB-16-OPN	16	2224	226	22.2758	63.50	44.450	35.719	53.975	28.575	26.988	#8	4.763	6.858	9.525
MSPB-20-OPN	20	2669	275	24.2824	69.85	47.625	39.688	60.325	31.750	26.988	#8	4.763	7.620	11.113
MSPB-25-OPN	25	4248	453	29.9466	82.55	66.675	50.800	73.025	44.450	34.925	#10	5.558	9.144	17.463
MSPB-30-OPN	30	6228	907	37.2110	101.60	85.725	65.088	88.900	50.800	44.450	#10	5.558	10.770	20.638

## Double Roller Pillow Block MDPB-OPN

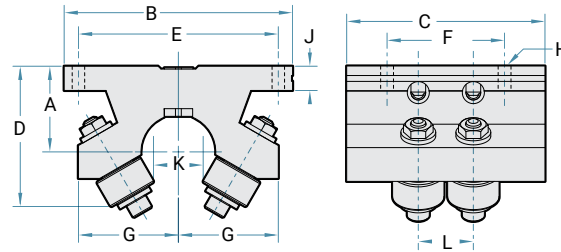

Dimensions and Load Ratings Metric Shafting

Part Number	Shaft Diameter mm	DYN. Load Rating N	Weight g	A	B	C	D	E	F	G	H		J	K	L
				±0.08 mm	mm	mm	mm	±0.13 mm	±0.13 mm	mm	Bolt	Hole mm	mm	mm	mm
MDPB-16-OPN	16	4448	317	22.2758	63.50	63.500	35.719	53.975	50.80	26.988	#8	4.763	6.858	9.525	14.2748
MDPB-20-OPN	20	5338	362	24.2824	69.85	66.675	39.688	60.325	31.75	26.988	#8	4.763	7.620	11.113	14.2748
MDPB-25-OPN	25	8496	544	29.9466	82.55	66.675	50.800	73.025	44.45	34.925	#10	5.558	9.144	17.463	18.2880
MDPB-30-OPN	30	12455	360	37.2110	101.60	85.725	65.088	88.900	50.80	44.450	#10	5.558	10.770	20.638	23.7998

## Twin Roller Pillow Block MTWN-OPN

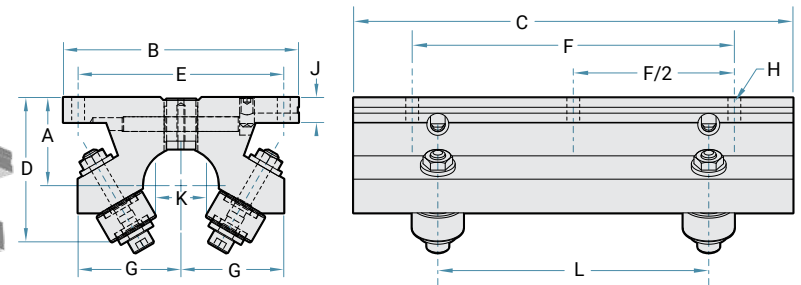

Dimensions and Load Ratings Metric Shafting

Part Number	Shaft Diameter mm	DYN. Load Rating N	Weight. g	A	B	C	D	E	F	G	H		J	K	L
				±0.08 mm	mm	mm	mm	±0.13 mm	±0.13 mm	in.	Bolt	Hole mm	mm	mm	mm
MTWN-16-OPN	16	4448	454	22.2758	63.50	101.6	35.719	53.975	76.2	26.988	#8	4.763	6.858	9.53	53.975
MTWN-20-OPN	20	5338	544	24.2824	69.85	114.3	39.688	60.325	88.9	26.988	#8	4.763	7.620	11.11	63.500
MTWN-25-OPN	25	8496	1043	29.9466	82.55	152.4	50.800	73.025	114.3	34.925	#10	5.558	9.144	17.46	95.250
MTWN-30-OPN	30	12455	1995	37.2110	101.60	190.5	65.088	88.900	139.7	44.450	#10	5.558	10.770	20.64	117.475

INCH

ISO METRIC

JIS METRIC

## Simplicity 60 Plus® Shafting

PBC Linear®, formulated a linear shaft designed specifically for optimal bearing performance – 60 Plus Shafting. Advanced process capabilities maintain the ideal surface finish for linear bearings resulting in the longest life and highest performing shaft-to-bearing combination available.

Optimized surface finish

Faster break-in and better Frelon® transfer for plain bearings

Longest life possible, less down time, and maintenance

Straight to within 0.001" to 0.002" per foot cumulative, except on 3/8" diameter and smaller



See Pages 59–60 for machining options.



## Metric Shaft Part • Numbering Chart



Configure Online

### Special

**CM** - Custom Machine  
**SL** - Specified Length

### Shaft Length

**Millimeter** - 0000

### Shaft Material

**No Entry** - 1060 CS

**SS** - 440 SS

**SS420** - 420 SS

**SS316** - 316 SS\* \*\*

**CP** - Chrome plate\*\*

**AR** - Armoloy\*\*

\* 300 Series available in most diameters

\*\*Available as special quotes

**Note:** Chrome will have a guaranteed thickness of 0.0001" to 0.0005".

Chrome thickness will be in addition to the catalog diameter of the shaft.

Code	Class Description
NIM	Metric Shaft (Steel)
NIPDM	Metric Predrill (Steel)
CCM	Feather Metric (Aluminum)
CCMDL	Feather Metric Predrill (Aluminum)
SRM	Metric Support Rail (Aluminum)
SRAM	Metric Support Rail Assembly (Aluminum)
LSRM	Metric Low Support Rail (Steel)
LSGM	Metric Low Support Rail Assembly (Steel)

Diameter	
Code	Desc.
04	4 mm
05	5 mm
06	6 mm
08	8 mm
10	10 mm
12	12 mm
16	16 mm
20	20 mm
25	25 mm
30	30 mm
40	40 mm
50	50 mm
60	60 mm
80	80 mm

### Sample Part Numbers

Stainless Steel (SS) 20 mm diameter and 300 mm long

**NIM20SS-0300-SL**

Feather metric 12 mm diameter and 150 mm long

**CCM12-0150-SL**

# Round Shafting RC60 Steel & Stainless Steel



## Simplicity® 60 Plus® Shafting

PBC Linear's® development team, working in close conjunction with engineers from Lee Linear®, have together formulated a linear shaft designed specifically for optimal bearing performance – Simplicity 60 Plus Shafting. Advanced process capabilities maintain the ideal surface finish for linear bearings resulting in the longest life and highest performing shaft-to-bearing combination available.

- Optimized surface finish
- Faster break-in and better Frelon® transfer for plain bearings
- Longest life possible, less down time, and maintenance
- Straight to within 0.001" to 0.002" per foot cumulative, except on 3/8" diameter and smaller

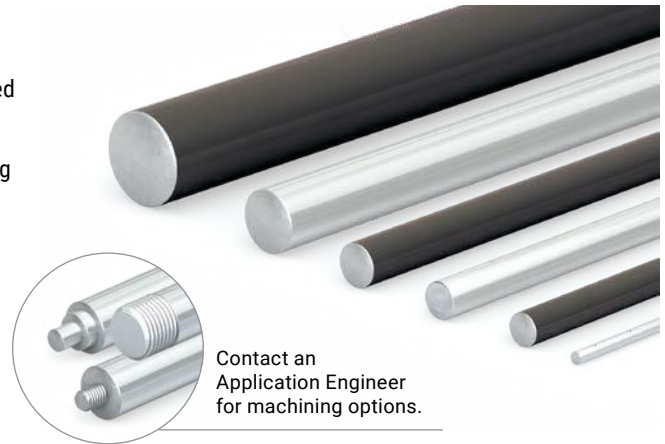

Contact an Application Engineer for machining options.

## RC60 Steel Solid Shafting NIM

Part No.	Nominal Dia. mm	Dia. Tolerance mm		MAX Length mm	MIN Hardness Depth mm	Weight Kg/M
		MIN	MAX			
NIM04-xxxx	4	3.987	4	6400	0.69	0.10
NIM05-xxxx	5	4.987	5	6400	0.69	0.15
NIM06-xxxx	6	5.987	6	6400	0.69	0.23
NIM08-xxxx	8	7.987	8	6400	0.69	0.39
NIM10-xxxx	10	9.987	10	6400	0.69	0.62
NIM12-xxxx	12	11.987	12	3900	1.02	0.89
NIM16-xxxx	16	15.987	16	3900	1.02	1.57
NIM20-xxxx	20	19.987	20	3900	1.52	2.45
NIM25-xxxx	25	24.987	25	4300	2.03	3.80
NIM30-xxxx	30	29.987	30	3900	2.03	5.50
NIM40-xxxx	40	39.984	40	3900	2.03	9.80
NIM50-xxxx	50	49.984	50	3900	2.54	15.30
NIM60-xxxx	60	59.981	60	3900	2.54	22.20
NIM80-xxxx	80	79.981	80	3550	2.54	39.50

- RC 60 Plus case hardened steel shafting
- Optimized for Simplicity® bearings and linear ball bearings
- Available cut-to-length or full lengths
- Length tolerance:  
4 mm – 30 mm shaft = +/- 0.8 mm  
40 mm – 50 mm shaft = +/- 1.6 mm  
60 mm – 80 mm shaft = +/- 3.2 mm
- Joinable for longer lengths
- Available as solid shafting or pre-drilled (See pre-drilled NIPDM on next page)

**Notes:** (1) Specify length in part number using millimeters.  
**Example:** for 25 mm shafting total length 900 mm = NIM25-0900.  
(2) Surface finish bearing recommended 8 Ra.



## 440 & 420 Stainless Steel Solid Shafting NIMxxSS & NIMxxSS420

Part No.		Nominal Size mm	Dia. Tolerance mm		MAX Length mm	MIN Hardness Depth mm	Weight Kg/M
440 SS	420 SS		MIN	MAX			
NIM04SS-xxxx	NIM04SS420-xxxx	4	3.987	4	6400	0.69	0.10
NIM05SS-xxxx*	NIM05SS420-xxxx*	5	4.987	5	6400	0.69	0.15
NIM06SS-xxxx	NIM06SS420-xxxx	6	5.987	6	6400	0.69	0.23
NIM08SS-xxxx	NIM08SS420-xxxx	8	7.987	8	6400	0.69	0.39
NIM10SS-xxxx	NIM10SS420-xxxx	10	9.987	10	6400	0.69	0.62
NIM12SS-xxxx	NIM12SS420-xxxx	12	11.987	12	3900	1.02	0.89
NIM16SS-xxxx	NIM16SS420-xxxx	16	15.987	16	3900	1.02	1.57
NIM20SS-xxxx	NIM20SS420-xxxx	20	19.987	20	3900	1.52	2.45
NIM25SS-xxxx	NIM25SS420-xxxx	25	24.987	25	4300	2.03	3.80
NIM30SS-xxxx	NIM30SS420-xxxx	30	29.987	30	3900	2.03	5.50
NIM40SS-xxxx	NIM40SS420-xxxx	40	39.984	40	3900	2.03	22.20
NIM50SS-xxxx	NIM50SS420-xxxx	50	49.984	50	3900	2.54	39.50

- 440 & 420 stainless steel RC 50 Plus™ hardness
- Optimized for Simplicity bearings and linear ball bearings
- Available cut-to-length or random lengths
- Length tolerance:  
4 mm – 30 mm shaft = +/- 0.8 mm  
40 mm – 50 mm shaft = +/- 1.6 mm  
60 mm – 80 mm shaft = +/- 3.2 mm
- Available as solid shafting or pre-drilled (See NIPDMxxSS on next page)

\*Limited availability on NIM05SS, please contact factory.



INCH

ISO METRIC

JIS METRIC

INCH

ISO METRIC

JIS METRIC

## Pre-Drilled & Tapped

Steel NIPDM • 440 Stainless Steel NIPDMxxSS • 420 Stainless Steel NIPDMxxSS420

Part No.			Nominal Dia. mm	Dia. Tolerance mm		Standard Hole Spacing		Thread	Max Length mm	Weight Kg/M
Steel	440 SS	420 SS		MIN	MAX	X	Y			
NIPDM12-xxxx	NIPDM12SS-xxxx	NIPDM12SS420-xxxx	12	11.9888	12	120	60	M4 x 0.7	4597	0.89
NIPDM16-xxxx	NIPDM16SS-xxxx	NIPDM16SS420-xxxx	16	15.9893	16	150	75	M5 x 0.8	4597	1.57
NIPDM20-xxxx	NIPDM20SS-xxxx	NIPDM20SS420-xxxx	20	19.9873	20	150	75	M6 x 1.0	4597	2.45
NIPDM25-xxxx	NIPDM25SS-xxxx	NIPDM25SS420-xxxx	25	24.9885	25	200	100	M8 x 1.25	4902	3.80
NIPDM30-xxxx	NIPDM30SS-xxxx	NIPDM30SS420-xxxx	30	29.9872	30	200	100	M10 x 1.5	4597	5.50
NIPDM40-xxxx	NIPDM40SS-xxxx	NIPDM40SS420-xxxx	40	39.9872	40	200	100	M10 x 1.5	4496	9.80
NIPDM50-xxxx	NIPDM50SS-xxxx	NIPDM50SS420-xxxx	50	49.9846	50	200	100	M12 x 1.75	4496	15.30

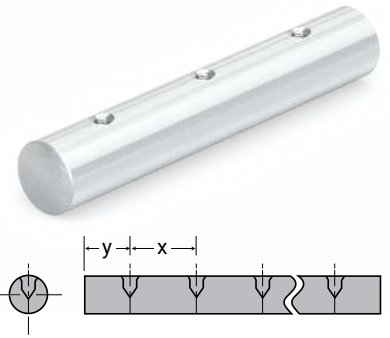

**Notes:** (1) Specify length in part number using mm.

**Example:** for 12 mm shafting total length 97 mm = NIPDM12-0097.

(2) Customer specifies 'y' dimension, if different than standard. Hole-to-hole tolerance = +/-0.015".

(3) Consult factory for chrome plated, 303, or 316 stainless steel shafting.

## Ceramic Coated

- Aluminum alloy base material
- RC 70 ceramic coated finish
- Designed to run with Simplicity® FrelonGOLD® lined bearings
- Interchanges with solid and pre-drilled shafting
- Non-magnetic and vibration resistant
- Weld splatter, paints, and contaminants will not stick
- NOT compatible with linear ball bearings
- Length tolerance:  
4 mm – 30 mm shaft = +/- 0.8 mm  
40 mm – 50 mm shaft = +/- 1.6 mm  
60 mm – 80 mm shaft = +/- 3.2 mm

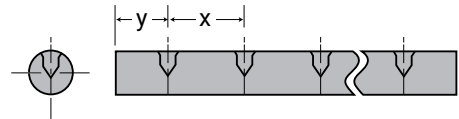

## Solid Shafting CCM

Part No.	Nominal Dia. mm	Dia. Tolerance mm		MAX Length mm	Weight Kg/M
		MIN	MAX		
CCM06-xxxx	6	5.992	6	3500	0.04
CCM08-xxxx	8	7.991	8	3500	0.07
CCM10-xxxx	10	9.991	10	3500	0.10
CCM12-xxxx	12	11.989	12	3500	0.15
CCM16-xxxx	16	15.989	16	3500	0.26
CCM20-xxxx	20	19.987	20	3500	0.41
CCM25-xxxx	25	24.987	25	3500	0.63
CCM30-xxxx	30	29.987	30	3500	0.92
CCM40-xxxx	40	39.984	40	3500	1.63
CCM50-xxxx	50	49.984	50	3500	2.55

**Notes:** (1) Specify length in part number using mm.

**Example:** for 8 mm shafting total length 97 mm = CCM08-0097.

(2) Ends of cut-to-length shafting are not coated.

(3) Fully coated shafting is available on special request.

## Pre-Drilled & Tapped CCMDL

Part No.	Nominal Dia. mm	Dia. Tolerance mm		Standard Hole Spacing		Thread	MAX Length mm	Weight Kg/M
		MIN	MAX	X	Y			
CCMDL08-xxxx	8	7.991	8	101.6	50.8	M2 x 0.4	3500	0.07
CCMDL10-xxxx	10	9.991	10	101.6	50.8	M3 x 0.5	3500	0.10
CCMDL12-xxxx	12	11.989	12	120	60	M4 x 0.7	3500	0.15
CCMDL16-xxxx	16	15.989	16	150	75	M5 x 0.8	3500	0.26
CCMDL20-xxxx	20	19.987	20	150	75	M6 x 1.0	3500	0.41
CCMDL25-xxxx	25	24.987	25	200	100	M8 x 1.25	3500	0.63
CCMDL30-xxxx	30	29.987	30	200	100	M10 x 1.5	3500	0.92

**Notes:** (1) Specify length in part number using mm.

**Example:** for 10 mm shafting total length 97 mm = CCMDL08-0097.

(2) Ends of cut-to-length shafting are not coated.

(3) Fully coated shafting is available on special request.

(4) Customer specifies 'y' dimension, if different than standard.

# Shafting Rail Assemblies

## Rail Assembly – Aluminum Support Rail SRA

Two piece assembly RC60 steel shaft and aluminum support rail standard

Other shaft materials – 440 stainless steel, 420 stainless steel, and ceramic coated aluminum

Standard length tolerances are provided on page 51

No coating

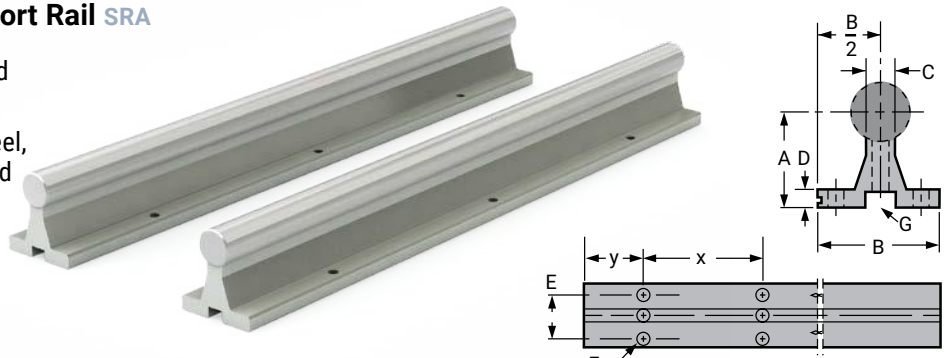

Shaft Size	Part No.		Nominal Dia. MM	Diameter Tolerance		A +/-0.05	B	C	D	E	F Hole Size	Standard Hole Spacing		Weight Kg/M
	Material**	Length		MIN	MAX							x	y	
SRAM12	_____	_____SL	12	11.9888	12	28.00	43.00	6.60	4.76	29	M4	120	60	1.80
SRAM16	_____	_____SL	16	15.9893	16	28.50	48.00	7.94	6.35	33	M5	150	75	2.59
SRAM20	_____	_____SL	20	19.9873	20	38.00	56.00	9.53	6.35	37	M6	150	75	3.61
SRAM25	_____	_____SL	25	24.9885	25	42.00	60.00	12.70	6.35	42	M8	200	100	5.86
SRAM30	_____	_____SL	30	29.9872	30	53.00	74.00	14.29	7.94	51	M10	200	100	8.80
SRAM40	_____	_____SL	40	39.9872	40	64.00	78.00	17.46	9.53	55	M10	200	100	12.70
SRAM50	_____	_____SL	50	49.9846	50	70.00	82.00	20.30	10.50	62	M12	200	100	21.98

● Part Numbers are complete when **Material** and **Length** are added. Default material is 1060 steel when no Material is specified.

\*\*For other steel options add below code into **Material** location:

- CC Ceramic Coated Shafting
- SS 440 Stainless Steel
- SS420 420 Stainless Steel

**Note:** Specify length in part number using millimeters.

**Example:** for 20 mm shafting total length 914 mm long = SRAM20-0914-SL. Customer specifies 'y' dimension, if different than standard.

**Contact PBC Linear for other available hole patterns.**

\* For diameter tolerances on Ceramic Coated Shafting, see tables on page 92.

**Example 1:** The Complete Part Number for a 1 inch diameter 440 Stainless Steel shaft of 240 mm is SRAM16SS-0240-SL

## Support Rail – Aluminum SR & SR\_PD

### Non-Drilled (SRM)



### Pre-Drilled (SRMxxPD)

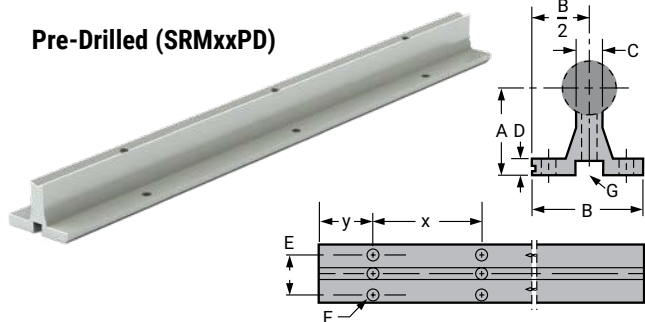

Part No.		Nominal Dia. MM	A +/-0.05	B	C	D	E	H Hole Size	G Mounting Bolt Size		MAX Length +/-3.2 mm	Standard Hole Spacing		Weight Kg/M
Non-Drilled	Pre-Drilled								Screw	Fastener Length mm		x	y	
SRM12	SRM12PD	12	28.00	43.00	6.60	4.76	29	M4	M4 x 0.70	20	1200	120	60	0.803
SRM16	SRM16PD	16	28.50	48.00	7.94	6.35	33	M5	M5 x 0.80	20	1200	150	75	1.040
SRM20	SRM20PD	20	38.00	56.00	9.53	6.35	37	M6	M6 x 1.00	30	1200	150	75	1.380
SRM25	SRM25PD	25	42.00	60.00	12.70	6.35	42	M8	M8 x 1.25	40	1200	200	100	1.860
SRM30	SRM30PD	30	53.00	74.00	14.29	7.94	51	M10	M10 x 1.5	40	1200	200	100	2.590
SRM40	SRM40PD	40	64.00	78.00	17.46	9.53	55	M10	M10 x 1.5	50	1200	200	100	3.750
SRM50	SRM50PD	50	70.00	82.00	20.30	10.50	62	M12	M12 x 1.75	70	1200	200	100	6.110

**Notes:** (1) Specify length in part number. **Example:** for 12 mm shafting support rail to 609 mm length = SRM12-0609 (Aluminum alloy construction, no coating).

(2) Shafts and support rails sold separately. Customer specifies 'y' dimension. Shaft rails and assemblies are available in long lengths, consult factory.

INCH

ISO METRIC

JIS METRIC

## Low Support Rail – Steel LSRM

The AISI C-1018 steel LSRM shaft support is a low support rail with a reduced footprint, and 40% lower profile than other support rails. This is an excellent choice for applications requiring compact low shaft support. The standard length for LSRM type supports is 1200 mm.

No coating

Length tolerance  
+0 mm/3 mm.

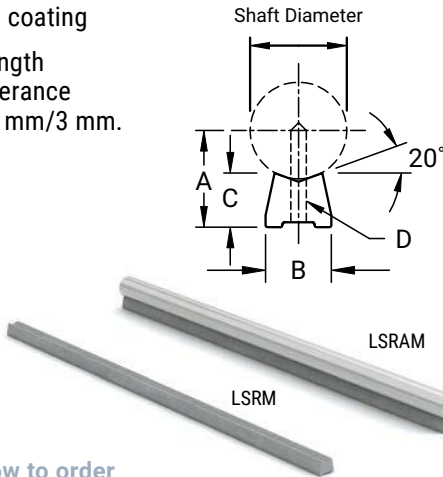

Part No.	Assembly Part No.	Shaft Dia. mm	A +/-0.05	B +/-0.05	C +/-0.05	D Hole Size	Standard Hole spacing pre-drilled		Weight per 1219 mm (approximate) Kg	Assembly Weight per 1200 mm (approximate) Kg
							X	Y		
LSRM12 LSRM12PD	LSRAM-12	12	13.91	9.40	8.66	M4	120	60	0.599	1.79
LSRM16 LSRM16PD	LSRAM-16	16	17.54	11.43	10.46	M5	150	75	0.884	2.76
LSRM20 LSRM20PD	LSRAM-20	20	19.58	12.95	10.46	M6	150	75	1.020	3.61
LSRM25 LSRM25PD	LSRAM-25	25	25.22	17.53	14.22	M8	200	100	1.980	5.86
LSRM30 LSRM30PD	LSRAM-30	30	29.26	19.81	15.9	M10	200	100	2.480	8.80
LSRM40 LSRM40PD	LSRAM-40	40	35.96	23.62	17.86	M10	200	100	3.340	12.70
LSRM50 LSRM50PD	LSRAM-50	50	44.02	29.97	21.46	M12	200	100	5.030	21.98

### How to order

- Available as cut to length options up to a max length of 3657 mm.  
**Example:** 1200 mm would be LSRM16-1200-SL
- If standard mounting holes are required, specify low shaft rails with pre-drilled mounting holes by part number.  
**Example:** LSRM12PD. Hole sizes and spacings are shown in the table.
- If other than standard hole spacing is required, please provide drawings with all dimensions, tolerances, and quantity. With or without mounting holes, low shaft rails will be supplied in 1200 mm lengths when ordered by part number.

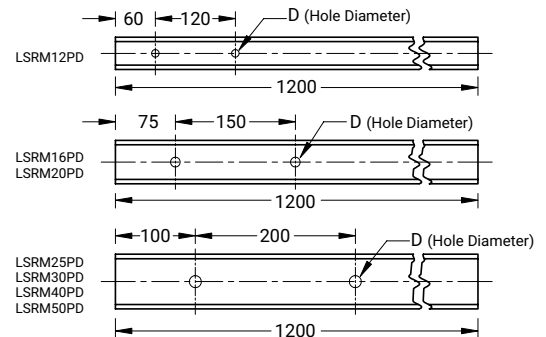

## Low Support Rail & Shaft Set LSG

Precision case hardened and ground shaft, plus an LSR steel support rail, effectively doubles the life of the shaft by allowing it to be turned over for a fresh surface when wear becomes evident. Both sides of the shaft are counterbored so the shaft may be rotated 180°, and rebolted for use on the new side. This guide is sold as a two-piece set; the shaft and support are not assembled. The guide is then bolted down through the top of the shaft to reduce installation time. The shafts are also available in 400 series stainless steel. Drilled through and counterbored shafts may not be suitable for all linear bearings.

No coating



Part No.	Shaft Dia. mm	H mm	B mm	Y mm	X mm	N mm	Weight per in. Kg
LSGM16	16	17.54	11.43	75	150	#5	2.36
LSGM20	20	19.58	12.95	75	150	#6	3.05
LSGM25	25	25.22	17.53	100	200	#10	5.55
LSGM30	30	29.26	19.81	100	200	5/16	8.11
LSGM40	40	35.96	23.62	100	200	3/8	11.43
LSGM50	50	44.02	29.97	100	200	1/2	19.98

**Note:** Customer specifies 'y' dimension.

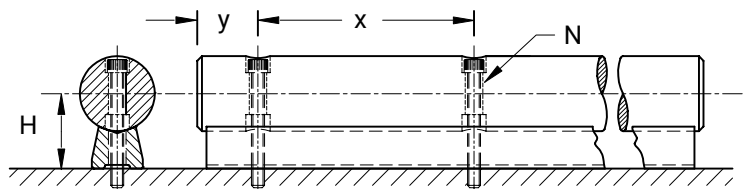

# Simplicity® Linear Plain Bearings

Linear Plain Bearing **FJ & FJN** \*Self Aligning O.D. (FJA-XX)

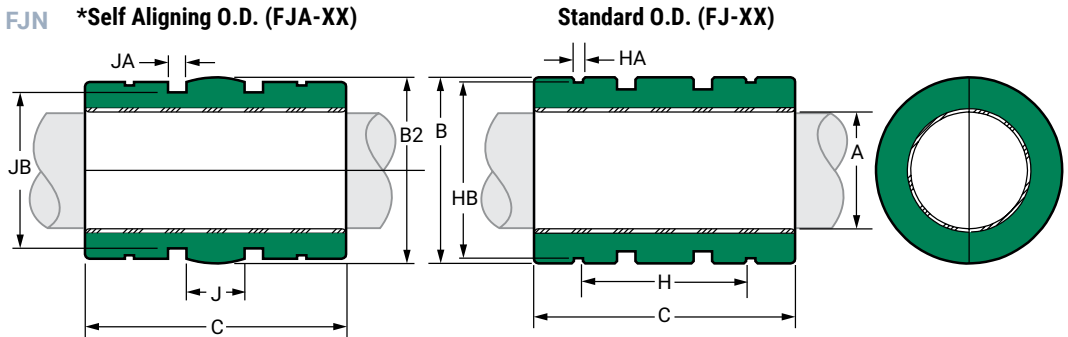

\* Except for the O.D., bearings with the self-aligning feature have the same dimensions and tolerances as the standard bearing. There is a spherical crown on the O.D. to create the self-aligning feature. They are for use in a straight bore housing. Add an "A" to the part number for self-aligning bearings.

## DIMENSIONAL INFORMATION

Precision I.D. Series Similar to Preloaded Ball Bearing					Compensated I.D. Series Allows Additional Running Clearance				B		B2		C Length		Concentric	Bearing Weight
Part No.		Nominal Size	A Bearing I.D.		Part No.		A Bearing I.D.		Standard O.D.		Self-Aligning O.D. FJA				MAX	Kg.
Closed	Open	mm	MIN	MAX	Closed	Open	MIN	MAX	MIN	MAX	MIN	MAX	MIN	MAX		
FJ06	N/A	6	6.010	6.028	FJC 06	FJCN 06	6.06	6.078	11.989	12	11.943	11.968	18.619	19	0.0254	0.004
FJH 08	FJHN 08	8	8.013	8.035	FJCH 08	FJCHN 08	8.063	8.085	14.989	15	14.943	14.968	16.619	17	0.0254	0.005
FJ 08	FJN 08	8	8.013	8.035	FJC 08	FJCN 08	8.063	8.085	14.989	15	14.943	14.968	23.619	24	0.0254	0.008
FJ 10	FJN 10	10	10.013	10.035	FJC 10	FJCN 10	10.063	10.086	18.987	19	18.936	18.969	28.619	29	0.0254	0.015
FJ 12	FJN 12	12	12.016	12.043	FJC 12	FJCN 12	12.066	12.093	20.987	21	20.942	20.968	29.619	30	0.0254	0.018
FJ 13	FJN 13	13	13.016	13.043	FJC 13	FJCN 13	13.066	13.093	22.987	23	22.944	22.969	31.619	32	0.0254	0.024
FJ 16	FJN 16	16	16.016	16.043	FJC 16	FJCN 16	16.066	16.093	27.988	28	27.943	27.968	36.619	37	0.0254	0.039
FJ 20	FJN 20	20	20.020	20.053	FJC 20	FJCN 20	20.096	20.129	31.984	32	31.941	31.966	41.619	42	0.0254	0.052
FJ 25	FJN 25	25	25.020	25.053	FJC 25	FJCN 25	25.096	25.129	39.984	40	39.942	39.967	58.619	59	0.0254	0.119
FJ 30	FJN 30	30	30.020	30.053	FJC 30	FJCN 30	30.096	30.129	44.984	45	44.940	44.966	63.619	64	0.0254	0.149
FJ 35	FJN 35	35	35.020	35.053	FJC 35	FJCN 35	35.100	35.136	51.981	52	51.940	51.966	69.619	70	0.0254	0.212
FJ 38	FJN 38	38	38.025	38.064	FJC 38	FJCN 38	38.127	38.166	56.981	57	56.940	56.966	75.619	76	0.0254	0.284
FJ 40	FJN 40	40	40.025	40.064	FJC 40	FJCN 40	40.127	40.166	59.981	60	59.939	59.964	79.619	80	0.0254	0.333
FJ 50	FJN 50	50	50.025	50.064	FJC 50	FJCN 50	50.127	50.166	79.981	80	79.939	79.964	99.619	100	0.0254	0.823
FJ 60	FJN 60	60	60.030	60.076	FJC 60	FJCN 60	60.182	60.228	89.978	90	89.939	89.964	109.619	110	0.0254	1.024
FJ 80	FJN 80	80	80.030	80.076	FJC 80	FJCN 80	80.182	80.228	119.978	120	119.939	119.964	139.619	140	0.0380	2.359
FJ 100	FJN 100	100	100.030	100.076	FJC 100	FJCN 100	100.182	100.228	149.975	150	149.936	149.962	174.619	175	0.0510	4.651
FJ 120	FJN 120	120	120.035	120.089	FJC 120	FJCN 120	120.190	120.236	179.975	180	179.936	179.962	199.619	200	0.0510	7.706
FJ 150	FJN 150	150	150.035	150.089	FJC 150	FJCN 150	150.190	150.236	209.971	210	209.934	209.959	239.619	240	0.0510	11.104

## MOUNTING DIMENSIONS

Part No.		Nominal Size	H	HA	HB	Ret. Ring Part No.	J	JA	JB	Metric O'ring Size
Closed	Open	mm	Between RET. Rings	RET. Ring GRV. Width	RET. Ring GRV. Dia.	JIS B 2904	Between O'ring GRVS.	O'ring GRV. Width	O'ring GRV. Dia.	
FJ06	N/A	6	11.3	1.15	11.5	STW - 12	4.293	2.032	9.859	9.7 x 1.3
FJH 08	FJHN08	8	9.2	1.15	14.3	STW - 15	2.540	2.362	12.243	12 x 1.7
FJ 08	FJN08	8	15.2	1.15	14.3	STW - 15	7.493	2.362	12.243	12 x 1.7
FJ 10	FJN 10	10	19.3	1.35	18.0	STW - 19	9.500	2.362	15.700	15.5 x 2
FJ 12	FJN 12	12	20.3	1.35	20.0	STW - 20	10.490	2.362	18.546	18 x 1.5
FJ 13	FJN 13	13	20.3	1.35	22.0	STW - 23	11.481	2.362	20.544	20 x 1.5
FJ 16	FJN 16	16	23.2	1.65	26.6	STW - 28	11.100	3.556	23.978	23.5 x 2.5
FJ 20	FJN 20	20	27.2	1.65	30.3	STW - 32	15.977	3.556	27.864	27.5 x 2.5
FJ 25	FJN 25	25	37.2	1.85	38.0	STW - 40	19.990	3.556	35.865	35.5 x 2.5
FJ 30	FJN 30	30	40.7	1.85	42.5	STW - 45	22.479	3.556	40.843	40 x 2.5
FJ 35	FJN 35	35	44.8	2.20	49.0	STW - 52	25.984	4.115	46.200	46 x 3.5
FJ 38	FJN 38	38	54.3	2.20	54.5	STW - 58	28.499	4.115	51.200	51 x 3.5
FJ 40	FJN 40	40	56.1	2.20	57.0	STW - 60	29.997	4.115	54.225	53 x 3.5
FJ 50	FJN 50	50	68.6	2.70	76.5	STW - 80	39.980	4.750	74.193	73 x 3.5
FJ 60	FJN 60	60	78.7	3.15	86.5	STW - 90	44.983	7.036	81.738	81 x 5
FJ 80	FJN 80	80	97.2	4.15	116.0	STW - 120	59.995	7.137	111.727	111 x 5
FJ 100	FJN 100	100	117.2	4.15	145.0	STW - 150	74.981	7.137	141.199	140 x 5.3
FJ 120	FJN 120	120	150.3	4.15	175.0	STW - 180	89.992	7.137	171.740	170 x 5
FJ 150	FJN 150	150	160.3	5.15	204.0	STW - 210	104.978	7.137	201.193	200 x 5.3

# Simplicity® Linear Plain Bearings

## Linear Plain Bearing FJ & FJN

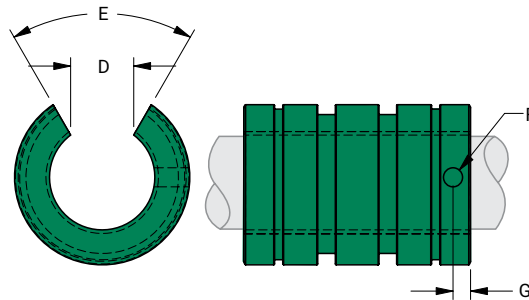

### OPEN DIMENSIONAL INFORMATION

Part No.		Nominal Size	D Slot Width MIN.	E Slot Angle	F Ret. Hole Dia.	G Ret. Hole Loc.	Bearing Weight
Precision	Compensated	mm					Kg.
FJHN 08	FJHCN 08	8	5.1	60	2.200	8.460	0.004
FJN 08	FJCN 08	8	5.1	60	2.200	11.940	0.006
FJN 10	FJCN 10	10	7.0	80	3.454	1.941	0.012
FJN 12	FJCN 12	12	8.0	80	3.454	1.941	0.014
FJN 13	FJCN 13	13	9.0	80	3.454	2.441	0.018
FJN 16	FJCN 16	16	11.0	80	3.454	3.019	0.030
FJN 20	FJCN 20	20	11.0	60	3.454	3.175	0.044
FJN 25	FJCN 25	25	12.0	50	3.454	3.175	0.102
FJN 30	FJCN 30	30	15.0	50	5.105	4.763	0.128
FJN 35	FJCN 35	35	17.0	50	5.105	4.763	0.182
FJN 38	FJCN 38	38	18.0	50	5.105	4.763	0.245
FJN 40	FJCN 40	40	20.0	50	5.105	4.763	0.286
FJN 50	FJCN 50	50	25.0	50	6.731	7.938	0.709
FJN 60	FJCN 60	60	30.0	50	6.731	7.938	0.882
FJN 80	FJCN 80	80	40.0	50	6.731	13.181	2.031
FJN 100	FJCN 100	100	50.0	50	6.731	14.500	4.005
FJN 120	FJCN 120	120	85.0	80	6.731	16.103	5.994
FJN 150	FJCN 150	150	105.0	80	6.731	17.350	8.637

### LOAD & SPEED DATA

Part No.	Effective Surface Area CM <sup>2</sup>	MAX Static Load Kg Frelon®		Effective Surface Area CM <sup>2</sup>	MAX Static Load N Frelon	
		GOLD	J & W		GOLD	J & W
FJ 06	1.1	528	264	1.14	2348	1174
FJH 08	1.4	630	315	1.40	2805	1402
FJ 08	1.9	890	445	1.90	3962	1981
FJ 10	2.9	1344	672	2.90	5982	2991
FJ 12	3.6	1666	833	3.60	7413	3707
FJ 13	4.0	1926	963	4.00	8570	4285
FJ 16	5.9	2741	1371	5.90	12199	6099
FJ 20	8.4	3887	1944	8.40	17298	8649
FJ 25	15.0	6827	3413	15.00	30379	15189
FJ 30	19.0	8885	4442	19.00	39538	19769
FJ 35	25.0	11340	5670	25.00	50462	25231
FJ 38	29.0	13363	6681	29.00	59464	29732
FJ 40	32.0	14808	7404	32.00	65896	32948
FJ 50	50.0	23138	11569	50.00	102963	51482
FJ 60	66.0	30542	15212	66.00	135911	67956
FJ 80	112.0	51829	25914	112.00	230637	115319
FJ 100	175.0	80982	40491	175.00	360371	180185
FJ 120	240.0	111061	55531	240.00	494222	247111
FJ 150	360.0	166592	83296	360.00	741334	370667

**Note:** MAX PV (m/min. \* kg/sq. cm)

FrelonGOLD® = 430 PV

Frelon J = 215 PV

MAX Speed Running Dry (m/min.)

FrelonGOLD = 91.4

Frelon J = 42.6

MAX Speed Running with Lubrication (m/min.)

FrelonGOLD = 251.5

Frelon J = 122

MAX PV (m/s. \* N/mm<sup>2</sup>)

FrelonGOLD = 0.70 PV

Frelon J = 0.35 PV

MAX Speed Running Dry (m/s)

FrelonGOLD = 1.52

Frelon J = 0.71

MAX Speed Running with Lubrication (m/s)

FrelonGOLD = 4.19

Frelon J = 2.03



**Plain Bearing Accessories: Retaining Rings, Seals, O-Rings**  
page 29



**Only certified Simplicity 60 Plus Shafting provides maximum linear bearing performance.**

**Inch Series—page 52 Metric Series—page 90**

# Simplicity® Flange Bearings

## Flange Bearings SFPJ

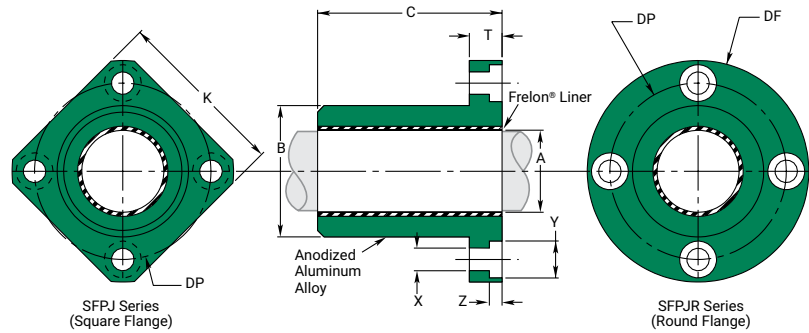

## DIMENSIONAL INFORMATION

Precision I.D. Series Similar to Preloaded Ball Bearing					Compensated I.D. Series Similar to Standard Ball Bearing				B Body O.D. H7		C Length H13		Effective Surface Area CM <sup>2</sup>	MAX Static Load N	
Part No.		Nominal Size mm	A Bearing I.D. F8		Part No.		A Bearing I.d.		MIN	MAX	MIN	MAX		Frelon® GOLD	J & W
Square	Round		MIN	MAX	Square	Round	MIN	MAX							
SFPJ 06	SFPJR 06	6	6.010	6.028	SFPJ 06C	SFPJR 06C	6.060	6.078	11.982	12	18.8	19	1.194	2462	1236
SFPJ 08	SFPJR 08	8	8.013	8.035	SFPJ 08C	SFPJR 08C	8.063	8.085	14.982	15	23.8	24	2.011	4140	2080
SFPJ 10	SFPJR 10	10	10.013	10.035	SFPJ 10C	SFPJR 10C	10.063	10.085	18.979	19	28.8	29	3.037	6259	3139
SFPJ 12	SFPJR 12	12	12.016	12.043	SFPJ 12C	SFPJR 12C	12.066	12.093	20.979	21	29.8	30	3.770	7770	3904
SFPJ 13	SFPJR 13	13	13.016	13.043	SFPJ 13C	SFPJR 13C	13.066	13.093	22.979	23	31.8	32	4.356	8976	4503
SFPJ 16	SFPJR 16	16	16.016	16.043	SFPJ 16C	SFPJR 16C	16.066	16.093	27.979	28	36.8	37	6.199	12773	6416
SFPJ 20	SFPJR 20	20	20.020	20.053	SFPJ 20C	SFPJR 20C	20.096	20.129	31.975	32	41.8	42	8.796	18119	9104
SFPJ 25	SFPJR 25	25	25.020	25.053	SFPJ 25C	SFPJR 25C	25.096	25.129	39.975	40	58.7	59	15.446	31824	15980
SFPJ 30	SFPJR 30	30	30.020	30.053	SFPJ 30C	SFPJR 30C	30.096	30.129	44.975	45	63.7	64	20.106	41418	20797
SFPJ 35	SFPJR 35	35	35.020	35.053	SFPJ 35C	SFPJR 35C	35.096	35.129	51.970	52	69.7	70	25.656	52856	26536
SFPJ 40	SFPJR 40	40	40.025	40.064	SFPJ 40C	SFPJR 40C	40.127	40.166	59.970	60	79.7	80	33.510	69033	34669
SFPJ 50	SFPJR 50	50	50.025	50.064	SFPJ 50C	SFPJR 50C	50.127	50.166	79.965	80	99.7	100	52.360	107871	54161
SFPJ 60	SFPJR 60	60	60.030	60.076	SFPJ 60C	SFPJR 60C	60.182	60.228	89.965	90	109.6	110	69.115	142382	71495
SFPJ 80	SFPJR 80	80	80.030	80.076	SFPJ 80C	SFPJR 80C	80.182	80.228	119.965	120	139.6	140	117.286	241620	121330

- Notes: (1) Formula used for effective surface area is  $(\pi * ID * L)/3$ .  
 (2) MAX static load is effective surface area times MAX load for FrelonGOLD®.  
 (3) - 210 kgf/cm<sup>2</sup> is the rating for FrelonGOLD®; 105.45 kgf/cm<sup>2</sup> is the rating for Frelon J.

## MOUNTING DIMENSIONS

Part No.		K	DF	T	DP	X	Y	Z	Clamping Bolt	Concentricity	Squareness	SFPJ Weight	SFPJR Weight
Square	Round	Square MAX	O.D. MAX	Length MAX	Bolt Circle	Hole	C'Bore Dia.	C'Bore Depth				Kg	Kg
SFPJ 06	SFPJR 06	22	28	8	20	3.5	6	3.1	M 3	0.012	0.012	0.011	0.014
SFPJ 08	SFPJR 08	25	32	8	24	3.5	6	3.1	M 3	0.012	0.012	0.017	0.021
SFPJ 10	SFPJR 10	30	40	9	29	4.5	7.5	4.1	M 4	0.012	0.012	0.029	0.038
SFPJ 12	SFPJR 12	32	42	9	32	4.5	7.5	4.1	M 4	0.012	0.012	0.033	0.042
SFPJ 13	SFPJR 13	34	43	9	33	4.5	7.5	4.1	M 4	0.012	0.012	0.041	0.048
SFPJ 16	SFPJR 16	37	48	9	38	4.5	7.5	4.1	M 4	0.012	0.012	0.058	0.069
SFPJ 20	SFPJR 20	42	54	11	43	5.5	9	5.1	M 5	0.015	0.015	0.081	0.097
SFPJ 25	SFPJR 25	50	62	11	51	5.5	9	5.1	M 5	0.015	0.015	0.158	0.174
SFPJ 30	SFPJR 30	58	74	14	60	6.6	11	6.1	M 6	0.015	0.015	0.216	0.252
SFPJ 35	SFPJR 35	64	82	14	67	6.6	11	6.1	M 6	0.017	0.017	0.292	0.338
SFPJ 40	SFPJR 40	75	96	18	78	9.0	14	8.1	M 8	0.017	0.017	0.467	0.547
SFPJ 50	SFPJR 50	92	116	18	98	9.0	14	8.1	M 8	0.017	0.017	0.999	1.104
SFPJ 60	SFPJR 60	106	134	24	112	11.0	17	11.1	M 10	0.020	0.020	1.359	1.550
SFPJ 80	SFPJR 80	136	164	24	142	11.0	17	11.1	M 10	0.020	0.020	2.873	3.048

# Simplicity® Flange Bearings

## Flange Bearings DFPJ

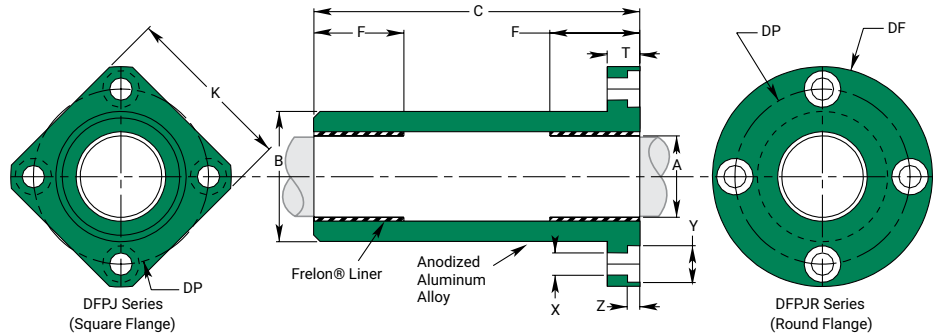

### DIMENSIONAL INFORMATION

Precision I.D. Series Similar to Preloaded Ball Bearing					Compensated I.D. Series Similar to Standard Ball Bearing				B Body O.D. H7		C Length		F Length Each End	Effective Surface Area CM <sup>2</sup>	MAX Static Load N	
Part No.		Nominal Size mm	A Bearing I.D. F8		Part No.		A BEARING I.D.		MIN	MAX	MIN	MAX			Frelon®	
Square	Round		MIN	MAX	Square	Round	MIN	MAX						GOLD	J & W	
DFPJ 06	DFPJR 06	6	6.010	6.028	DFPJ 06C	DFPJR 06C	6.060	6.078	11.982	12	34.7	35	12	1.508	3110	1560
DFPJ 08	DFPJR 08	8	8.013	8.035	DFPJ 08C	DFPJR 08C	8.063	8.085	14.982	15	44.7	45	12	2.011	4140	2080
DFPJ 10	DFPJR 10	10	10.013	10.035	DFPJ 10C	DFPJR 10C	10.063	10.085	18.979	19	54.7	55	14	2.932	6043	3031
DFPJ 12	DFPJR 12	12	12.016	12.043	DFPJ 12C	DFPJR 12C	12.066	12.093	20.979	21	56.7	57	15	3.770	7770	3904
DFPJ 13	DFPJR 13	13	13.016	13.043	DFPJ 13C	DFPJR 13C	13.066	13.093	22.979	23	60.7	61	16	4.356	8976	4503
DFPJ 16	DFPJR 16	16	16.016	16.043	DFPJ 16C	DFPJR 16C	16.066	16.093	27.979	28	69.7	70	20	6.702	13803	6936
DFPJ 20	DFPJR 20	20	20.020	20.053	DFPJ 20C	DFPJR 20C	20.096	20.129	31.975	32	79.7	80	22	9.215	18982	9535
DFPJ 25	DFPJR 25	25	25.020	25.053	DFPJ 25C	DFPJR 25C	25.096	25.129	39.975	40	111.6	112	33	17.279	35600	17874
DFPJ 30	DFPJR 30	30	30.020	30.053	DFPJ 30C	DFPJR 30C	30.096	30.129	44.975	45	122.6	123	35	21.991	45303	22749
DFPJ 35	DFPJR 35	35	35.020	35.053	DFPJ 35C	DFPJR 35C	35.096	35.129	51.970	52	134.6	135	40	29.322	60410	30333
DFPJ 40	DFPJR 40	40	40.025	40.064	DFPJ 40C	DFPJR 40C	40.127	40.166	59.970	60	150.6	151	44	36.861	75939	38131
DFPJ 50	DFPJR 50	50	50.025	50.064	DFPJ 50C	DFPJR 50C	50.127	50.166	79.965	80	191.6	192	70	73.304	151015	75831
DFPJ 60	DFPJR 60	60	60.030	60.076	DFPJ 60C	DFPJR 60C	60.182	60.228	89.965	90	208.6	209	73	91.735	188980	94892

- Notes: (1) Formula used for effective surface area is  $(\pi * ID * L)/3$ .  
 (2) MAX static load is effective surface area times MAX load for FrelonGOLD®.  
 (3) - 210 kgf/cm<sup>2</sup> is the rating for FrelonGOLD®; 105.45 kgf/cm<sup>2</sup> is the rating for Frelon J.  
 (4) Frelon pads in each end (F dimension).

### MOUNTING DIMENSIONS

Part No.		K Square MAX	DF O.D. MAX	T Length MAX	DP Bolt Circle	X Hole	Y C'Bore Dia.	Z C'Bore Depth	Clamping Bolt	Concentricity	Squareness	DFPJ Weight Kg	DFPJR Weight Kg
Square	Round												
DFPJ 06	DFPJR 06	22	28	8	20	3.5	6	3.1	M 3	0.015	0.015	0.015	0.018
DFPJ 08	DFPJR 08	25	32	8	24	3.5	6	3.1	M 3	0.015	0.015	0.024	0.028
DFPJ 10	DFPJR 10	30	40	9	29	4.5	7.5	4.1	M 4	0.015	0.015	0.044	0.053
DFPJ 12	DFPJR 12	32	42	9	32	4.5	7.5	4.1	M 4	0.015	0.015	0.051	0.060
DFPJ 13	DFPJR 13	34	43	9	33	4.5	7.5	4.1	M 4	0.015	0.015	0.063	0.071
DFPJ 16	DFPJR 16	37	48	9	38	4.5	7.5	4.1	M 4	0.015	0.015	0.096	0.107
DFPJ 20	DFPJR 20	42	54	11	43	5.5	9	5.1	M 5	0.017	0.017	0.133	0.149
DFPJ 25	DFPJR 25	50	62	11	51	5.5	9	5.1	M 5	0.017	0.017	0.270	0.286
DFPJ 30	DFPJR 30	58	74	14	60	6.6	11	6.1	M 6	0.017	0.017	0.360	0.397
DFPJ 35	DFPJR 35	64	82	14	67	6.6	11	6.1	M 6	0.020	0.020	0.501	0.547
DFPJ 40	DFPJR 40	75	96	18	78	9.0	14	8.1	M 8	0.020	0.020	0.776	0.856
DFPJ 50	DFPJR 50	92	116	18	98	9.0	14	8.1	M 8	0.020	0.020	1.780	1.885
DFPJ 60	DFPJR 60	106	134	24	112	11.0	17	11.1	M 10	0.025	0.025	2.329	2.519

# Simplicity® Flange Bearings

## Flange Bearings CFPJ

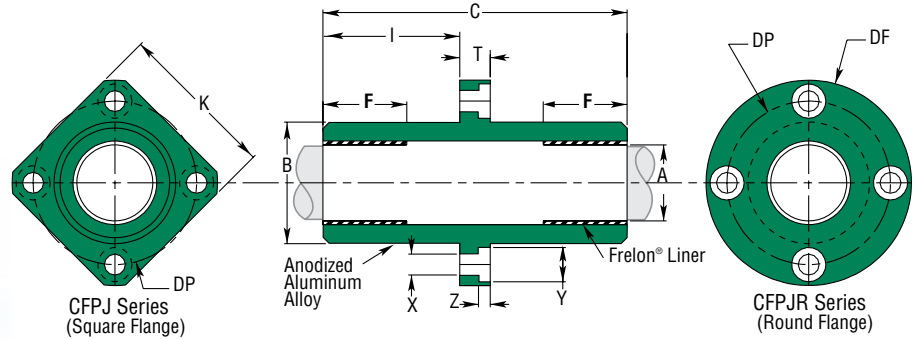

## DIMENSIONAL INFORMATION

Precision I.D. Series Similar to Preloaded Ball Bearing					Compensated I.D. Series Similar to Standard Ball Bearing				B		C		I	F	Effective Surface Area CM <sup>2</sup>	MAX Static Load N	
Part No.		Nominal Size mm	A Bearing I.D. F8		Part No.		A Bearing I.D.		Body O.D. H7		Length		Length To FLNG.	Length Each End		Frelon®	
Square	Round		MIN	MAX	Square	Round	MIN	MAX	MIN	MAX	MIN	MAX			GOLD	J & W	
CFPJ 06	CFPJR 06	6	6.010	6.028	CFPJ 06C	CFPJR 06C	6.060	6.078	11.982	12	34.7	35.3	13.5	12	1.508	3110	1560
CFPJ 08	CFPJR 08	8	8.013	8.035	CFPJ 08C	CFPJR 08C	8.063	8.085	14.982	15	44.7	45.3	18.5	12	2.011	4140	2080
CFPJ 10	CFPJR 10	10	10.013	10.035	CFPJ 10C	CFPJR 10C	10.063	10.085	18.979	19	54.7	55.3	23.0	14	2.932	6043	3031
CFPJ 12	CFPJR 12	12	12.016	12.043	CFPJ 12C	CFPJR 12C	12.066	12.093	20.979	21	56.7	57.3	24.0	15	3.770	7770	3904
CFPJ 13	CFPJR 13	13	13.016	13.043	CFPJ 13C	CFPJR 13C	13.066	13.093	22.979	23	60.7	61.3	26.0	16	4.356	8976	4503
CFPJ 16	CFPJR 16	16	16.016	16.043	CFPJ 16C	CFPJR 16C	16.066	16.093	27.979	28	69.7	70.3	30.5	20	6.702	13803	6936
CFPJ 20	CFPJR 20	20	20.020	20.053	CFPJ 20C	CFPJR 20C	20.096	20.129	31.975	32	79.7	80.3	34.5	22	9.215	18982	9535
CFPJ 25	CFPJR 25	25	25.020	25.053	CFPJ 25C	CFPJR 25C	25.096	25.129	39.975	40	111.7	112.3	50.5	33	17.279	35600	17874
CFPJ 30	CFPJR 30	30	30.020	30.053	CFPJ 30C	CFPJR 30C	30.096	30.129	44.975	45	122.7	123.3	54.5	35	21.991	45303	22749
CFPJ 35	CFPJR 35	35	35.020	35.053	CFPJ 35C	CFPJR 35C	35.096	35.129	51.970	52	134.7	135.3	60.5	40	29.322	60410	30333
CFPJ 40	CFPJR 40	40	40.025	40.064	CFPJ 40C	CFPJR 40C	40.127	40.166	59.970	60	150.7	151.3	66.5	44	36.861	75939	38131
CFPJ 50	CFPJR 50	50	50.025	50.064	CFPJ 50C	CFPJR 50C	50.127	50.166	79.965	80	191.7	192.3	87.0	70	73.304	151015	75831
CFPJ 60	CFPJR 60	60	60.030	60.076	CFPJ 60C	CFPJR 60C	60.182	60.228	89.965	90	208.7	209.3	92.5	73	91.735	188980	94892

- Notes: (1) Formula used for effective surface area is  $(\pi * ID * L)/3$ .  
 (2) MAX static load is effective surface area times MAX load for FrelonGOLD®.  
 (3) - 210 kgf/cm<sup>2</sup> is the rating for FrelonGOLD®; 105.45 kgf/cm<sup>2</sup> is the rating for Frelon J.  
 (4) Frelon pads in each end (F dimension).



Only certified Simplicity 60 Plus Shafting provides maximum linear bearing performance.

Inch Series—page 52 Metric Series—page 90

## MOUNTING DIMENSIONS

Part No.		K	DF	T	Dp	X	Y	Z	Clamping Bolt	Concentricity	Squareness	CFPJ Weight	CFPJR Weight
Square	Round	MAX	MAX	MAX	Circle	Hole	C'Bore Dia.	C'Bore Depth				Kg.	Kg.
CFPJ 06	CFPJR 06	22	28	8	20	3.5	6	3.1	M 3	0.015	0.015	0.015	0.018
CFPJ 08	CFPJR 08	25	32	8	24	3.5	6	3.1	M 3	0.015	0.015	0.024	0.028
CFPJ 10	CFPJR 10	30	40	9	29	4.5	7.5	4.1	M 4	0.015	0.015	0.044	0.053
CFPJ 12	CFPJR 12	32	42	9	32	4.5	7.5	4.1	M 4	0.015	0.015	0.051	0.060
CFPJ 13	CFPJR 13	34	43	9	33	4.5	7.5	4.1	M 4	0.015	0.015	0.063	0.071
CFPJ 16	CFPJR 16	37	48	9	38	4.5	7.5	4.1	M 4	0.015	0.015	0.096	0.107
CFPJ 20	CFPJR 20	42	54	11	43	5.5	9	5.1	M 5	0.017	0.017	0.133	0.149
CFPJ 25	CFPJR 25	50	62	11	51	5.5	9	5.1	M 5	0.017	0.017	0.270	0.286
CFPJ 30	CFPJR 30	58	74	14	60	6.6	11	6.1	M 6	0.017	0.017	0.360	0.397
CFPJ 35	CFPJR 35	64	82	14	67	6.6	11	6.1	M 6	0.020	0.020	0.501	0.547
CFPJ 40	CFPJR 40	75	96	18	78	9.0	14	8.1	M 8	0.020	0.020	0.776	0.856
CFPJ 50	CFPJR 50	92	116	18	98	9.0	14	8.1	M 8	0.020	0.020	1.780	1.885
CFPJ 60	CFPJR 60	106	134	24	112	11.0	17	11.1	M 10	0.025	0.025	2.329	2.519

# Linear Ball Bearings Precision

## Ball Bearings JP

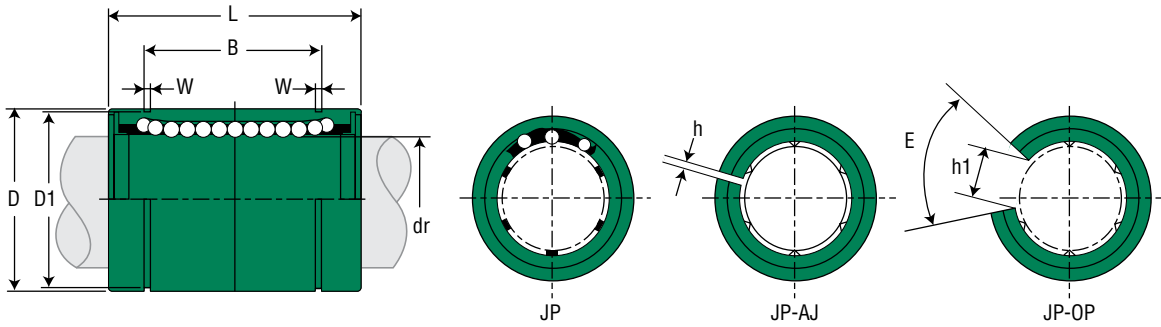

JP – Standard Closed

JPxx-AJ – Adjustable

JPxx-OP – Standard Open



### DIMENSIONAL INFORMATION

(Standard Steel Finish)

Part No.			Nominal Shaft Diameter				Major Dimensions & Tolerances							
Standard Closed	Adjustable	Standard Open	Size	dr	Tolerance	Ball Circuit	Weight	D	Tolerance	L	Tolerance	B	Tolerance	
mm	mm	mm	mm	mm	mm		G	mm	mm	mm	mm	mm	mm	
JP08G	-	-	8	8	0/-0.009	4	16	15	0/-0.011	24	0/-0.2	17.5	0/-0.2	
JP10G	-	-	10	10	0/-0.009	4	30	19	0/-0.013	29	0/-0.2	22	0/-0.2	
JP12G	JP12G-AJ	JP12G-OP	12	12	0/-0.009	4	31.5	21	0/-0.013	30	0/-0.2	23	0/-0.2	
JP13G	JP13G-AJ	JP13G-OP	13	13	0/-0.009	4	43	23	0/-0.013	32	0/-0.2	23	0/-0.2	
JP16G	JP16G-AJ	JP16G-OP	16	16	0/-0.009	5	69	28	0/-0.013	37	0/-0.2	26.5	0/-0.2	
JP20G	JP20G-AJ	JP20G-OP	20	20	0/-0.010	5	87	32	0/-0.016	42	0/-0.2	30.5	0/-0.2	
JP25G	JP25G-AJ	JP25G-OP	25	25	0/-0.010	6	220	40	0/-0.016	59	0/-0.3	41	0/-0.3	
JP30G	JP30G-AJ	JP30G-OP	30	30	0/-0.010	6	250	45	0/-0.016	64	0/-0.3	44.5	0/-0.3	
JP35G	JP35G-AJ	JP35G-OP	35	35	0/-0.012	6	390	52	0/-0.019	70	0/-0.3	49.5	0/-0.3	
JP40G	JP40G-AJ	JP40G-OP	40	40	+0/-0.012	6	585	60	0/-0.019	80	0/-0.3	60.5	0/-0.3	
JP50G	JP50G-AJ	JP50G-OP	50	50	+0/-0.015	6	1580	80	0/-0.022	100	0/-0.3	74	0/-0.3	

Part No.			Nominal Shaft Diameter			Major Dimensions & Tolerances							Load Ratings	
Standard Closed	Adjustable	Standard Open	Size	dr	Tolerance	W	D1	H	H1	E Slot Angle	MAX Eccentricity	MAX Radial Clearance	Dynamic C	Static Co
mm	mm	mm	mm	mm	mm	mm	mm	mm	mm	°	μm	μm	N	N
JP08G	-	-	8	8	0/-0.009	1.1	14.3	1	-	-	12	-5	260	400
JP10G	-	-	10	10	0/-0.009	1.3	18	1	-	-	12	-5	370	540
JP12G	JP12G-AJ	JP12G-OP	12	12	0/-0.009	1.3	20	1.5	8	80°	12	-5	410	590
JP13G	JP13G-AJ	JP13G-OP	13	13	0/-0.009	1.3	22	1.5	9	80°	12	-5	500	770
JP16G	JP16G-AJ	JP16G-OP	16	16	0/-0.009	1.6	27	1.5	11	80°	12	-7	770	1170
JP20G	JP20G-AJ	JP20G-OP	20	20	0/-0.010	1.6	30.5	1.5	11	60°	15	-7	860	1370
JP25G	JP25G-AJ	JP25G-OP	25	25	0/-0.010	1.85	38	2	12	50°	15	-9	980	1560
JP30G	JP30G-AJ	JP30G-OP	30	30	0/-0.010	1.85	43	2.5	15	50°	15	-9	1560	2740
JP35G	JP35G-AJ	JP35G-OP	35	35	0/-0.012	2.1	49	2.5	17	50°	20	-9	1660	3130
JP40G	JP40G-AJ	JP40G-OP	40	40	+0/-0.012	2.1	57	3	20	50°	20	-13	2150	4010
JP50G	JP50G-AJ	JP50G-OP	50	50	+0/-0.015	2.6	76.5	3	25	50°	20	-13	3820	7930

# Linear Ball Bearings Double Wide

## Double Wide Ball Bearings JP-W

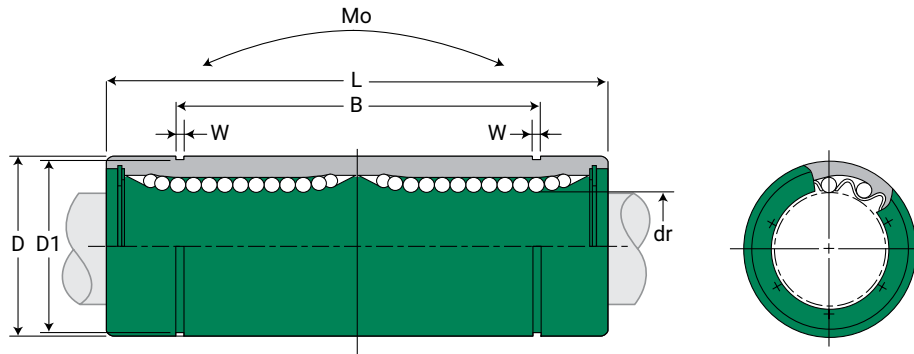

### DIMENSIONAL INFORMATION

(Standard Steel Finish)

Part No.	Nominal Shaft Diameter			Ball Circuit	Weight G	Major Dimensions & Tolerances						
	Standard Polymer Cage	Size mm	dr mm			Tolerance mm	D mm	Tolerance mm	L mm	Tolerance mm	B mm	Tolerance mm
JP08GW		8	8	0/-0.010	4	31	15	0/-0.013	45	0/-0.3	35	0/-0.3
JP12GW		12	12	0/-0.010	4	80	21	0/-0.016	57	0/-0.3	46	0/-0.3
JP16GW		16	16	0/-0.010	5	145	28	0/-0.016	70	0/-0.3	53	0/-0.3
JP20GW		20	20	0/-0.012	5	180	32	0/-0.019	80	0/-0.3	61	0/-0.3
JP25GW		25	25	0/-0.012	6	440	40	0/-0.019	112	0/-0.4	82	0/-0.4
JP30GW		30	30	0/-0.012	6	580	45	0/-0.019	123	0/-0.4	89	0/-0.4
JP40GW		40	40	0/-0.015	6	1170	60	0/-0.022	151	0/-0.4	121	0/-0.4
JP50GW		50	50	0/-0.015	6	3100	80	0/-0.022	192	0/-0.4	148	0/-0.4

Part No.	Nominal Shaft Diameter			Major Dimensions & Tolerances			Load Ratings		
	Standard Polymer Cage	Size mm	dr mm	Tolerance mm	W mm	D1 mm	MAX Eccentricity $\mu\text{m}$	Dynamic C N	Static Co N
JP08GW		8	8	0/-0.010	1.1	14.3	15	431	784
JP12GW		12	12	0/-0.010	1.3	20	15	657	1200
JP16GW		16	16	0/-0.010	1.6	27	15	1230	2350
JP20GW		20	20	0/-0.012	1.6	30.5	20	1400	2750
JP25GW		25	25	0/-0.012	1.85	38	20	1560	3140
JP30GW		30	30	0/-0.012	1.85	43	20	2490	5490
JP40GW		40	40	0/-0.015	2.1	57	25	3430	8040
JP50GW		50	50	0/-0.015	2.6	76.5	25	6080	15900



Only certified Simplicity 60 Plus Shafting provides maximum linear bearing performance.

Inch Series—page 52 Metric Series—page 90

# Linear Ball Bearings Square Flange Mount

## Ball Bearings – Square Flange Mount JPK

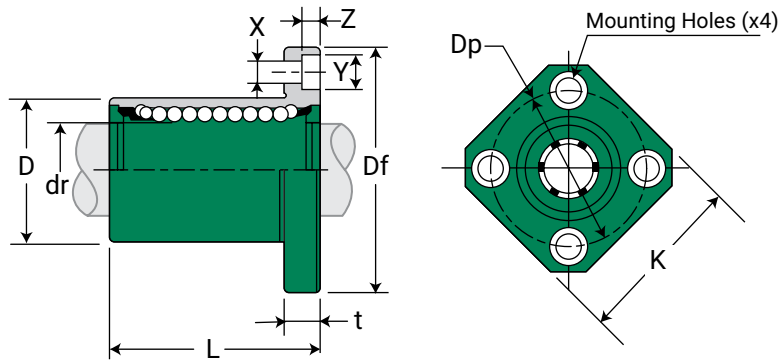

### DIMENSIONAL INFORMATION

(Standard Steel Finish)

Part No.	Nominal Shaft Diameter			Ball Circuit	Weight G	Major Dimensions & Tolerances				
	Standard Polymer Cage	Size mm	dr mm			Tolerance mm	D mm	Tolerance mm	L mm	Tolerance mm
JPK08G		8	8	0/-0.009	4	37	15	0/-0.013	24	±0.3
JPK12G		12	12	0/-0.009	4	76	21	0/-0.016	30	±0.3
JPK16G		16	16	0/-0.009	5	120	28	0/-0.016	37	±0.3
JPK20G		20	20	0/-0.010	5	180	32	0/-0.019	42	±0.3
JPK25G		25	25	0/-0.010	6	340	40	0/-0.019	59	±0.3
JPK30G		30	30	0/-0.010	6	470	45	0/-0.019	64	±0.3
JPK40G		40	40	0/-0.012	6	1060	60	0/-0.022	80	±0.3
JPK50G		50	50	0/-0.012	6	2200	80	0/-0.022	100	±0.3

Part No.	Nominal Shaft Diameter			Major Dimensions & Tolerances – Flange									Load Ratings		
	Standard Polymer Cage	Size mm	dr mm	Tolerance mm	Df mm	K mm	T mm	Dp mm	X mm	Y mm	Z mm	Eccentricity μm	Squareness μm	Dynamic C N	Static Co N
JPK08G		8	8	0/-0.009	32	25	5	24	3.5	6.5	3.1	12	12	274	392
JPK12G		12	12	0/-0.009	42	32	6	32	4.5	8	4.1	12	12	510	784
JPK16G		16	16	0/-0.009	48	37	6	38	4.5	8	4.1	12	12	774	1180
JPK20G		20	20	0/-0.010	54	42	8	43	5.5	9.3	5.1	15	15	882	1370
JPK25G		25	25	0/-0.010	62	50	8	51	5.5	9.3	5.1	15	15	980	1570
JPK30G		30	30	0/-0.010	74	58	10	60	6.6	11	6.1	15	15	1570	2740
JPK40G		40	40	0/-0.012	96	75	13	78	9	14	8.1	20	20	2160	4020
JPK50G		50	50	0/-0.012	116	92	13	98	9	14	8.1	20	20	3820	7940



Only certified Simplicity 60 Plus Shafting provides maximum linear bearing performance.

Inch Series—page 52 Metric Series—page 90

# Linear Ball Bearings Round Flange Mount

## Ball Bearings – Round Flange Mount JPF

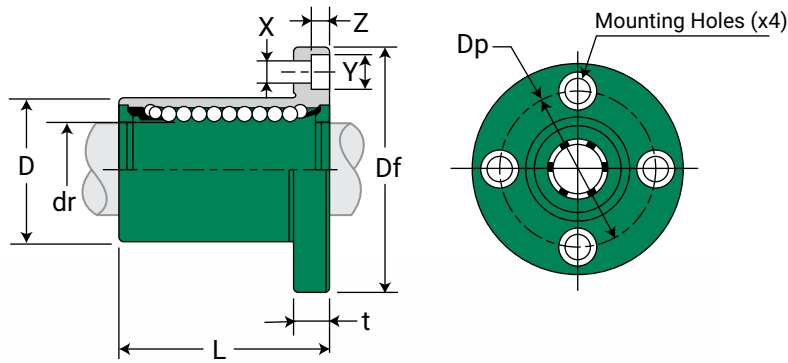

### DIMENSIONAL INFORMATION

(Standard Steel Finish)

Part No.	Nominal Shaft Diameter			Ball Circuit	Weight G	Major Dimensions & Tolerances				
	Standard Polymer Cage	Size mm	dr mm			Tolerance mm	D mm	Tolerance mm	L mm	Tolerance mm
JPF08G		8	8	0/-0.009	4	37	15	0/-0.013	24	±0.3
JPF12G		12	12	0/-0.009	4	76	21	0/-0.016	30	±0.3
JPF16G		16	16	0/-0.009	5	120	28	0/-0.016	37	±0.3
JPF20G		20	20	0/-0.010	5	180	32	0/-0.019	42	±0.3
JPF25G		25	25	0/-0.010	6	340	40	0/-0.019	59	±0.3
JPF30G		30	30	0/-0.010	6	470	45	0/-0.019	64	±0.3
JPF40G		40	40	0/-0.012	6	1060	60	0/-0.022	80	±0.3
JPF50G		50	50	0/-0.012	6	2200	80	0/-0.022	100	±0.3

Part No.	Nominal Shaft Diameter			Major Dimensions & Tolerances – Flange								Load Ratings		
	Standard Polymer Cage	Size mm	dr mm	Tolerance mm	Df mm	T mm	Dp mm	X mm	Y mm	Z mm	Eccentricity μm	Squareness μm	Dynamic C N	Static Co N
JPF08G		8	8	0/-0.009	32	5	24	3.5	6.5	3.1	12	12	274	392
JPF12G		12	12	0/-0.009	42	6	32	4.5	8	4.1	12	12	510	784
JPF16G		16	16	0/-0.009	48	6	38	4.5	8	4.1	12	12	774	1180
JPF20G		20	20	0/-0.010	54	8	43	5.5	9.3	5.1	15	15	882	1370
JPF25G		25	25	0/-0.010	62	8	51	5.5	9.3	5.1	15	15	980	1570
JPF30G		30	30	0/-0.010	74	10	60	6.6	11	6.1	15	15	1570	2740
JPF40G		40	40	0/-0.012	96	13	78	9	14	8.1	20	20	2160	4020
JPF50G		50	50	0/-0.012	116	13	98	9	14	8.1	20	20	3820	7940



Only certified Simplicity 60 Plus Shafting provides maximum linear bearing performance.

Inch Series—page 52 Metric Series—page 90

# Linear Ball Bearings Double Wide

## Double Wide Ball Bearings – Square Flange Mount JPK-W

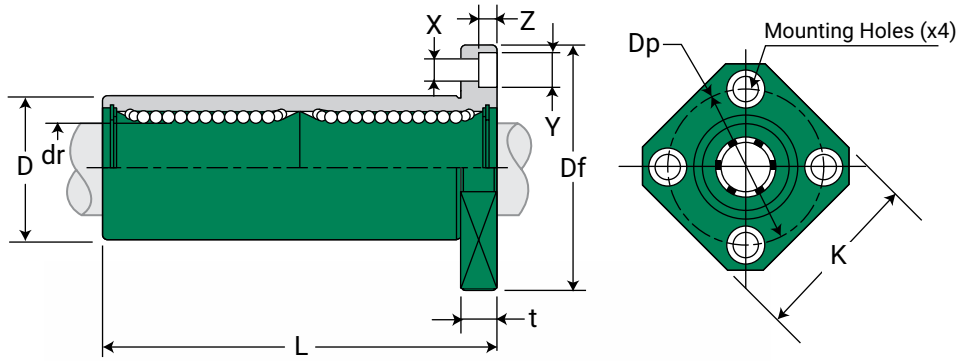

### DIMENSIONAL INFORMATION

(Standard Steel Finish)

Part No.	Nominal Shaft Diameter			Ball Circuit	Weight G	Major Dimensions & Tolerances				
	Standard Polymer Cage	Size mm	dr mm			Tolerance mm	D mm	Tolerance mm	L mm	Tolerance mm
JPK08GW		8	8	0/-0.010	4	43	15	0/-0.013	45	±0.3
JPK12GW		12	12	0/-0.010	4	90	21	0/-0.016	57	±0.3
JPK16GW		16	16	0/-0.010	5	165	28	0/-0.016	70	±0.3
JPK20GW		20	20	0/-0.010	5	225	32	0/-0.019	80	±0.3
JPK25GW		25	25	0/-0.012	6	500	40	0/-0.019	112	±0.3
JPK30GW		30	30	0/-0.012	6	590	45	0/-0.019	123	±0.3
JPK40GW		40	40	0/-0.015	6	1380	60	0/-0.022	154	±0.3
JPK50GW		50	50	0/-0.015	6	3400	80	0/-0.025	192	±0.3

Part No.	Nominal Shaft Diameter			Major Dimensions & Tolerances – Flange									Load Ratings		
	Standard Polymer Cage	Size mm	dr mm	Tolerance mm	Df mm	K mm	T mm	Dp mm	X mm	Y mm	Z mm	Eccentricity μm	Squareness μm	Dynamic C N	Static Co N
JPK08GW		8	8	0/-0.010	32	25	5	24	3.5	6.5	3.1	15	15	431	784
JPK12GW		12	12	0/-0.010	42	32	6	32	4.5	8	4.1	15	15	813	1570
JPK16GW		16	16	0/-0.010	48	37	6	38	4.5	8	4.1	15	15	1230	2350
JPK20GW		20	20	0/-0.010	54	42	8	43	5.5	9.3	5.1	20	20	1400	2740
JPK25GW		25	25	0/-0.012	62	50	8	51	5.5	9.3	5.1	20	20	1560	3140
JPK30GW		30	30	0/-0.012	74	58	10	60	6.6	11	6.1	20	20	2490	5490
JPK40GW		40	40	0/-0.015	96	75	13	78	9	14	8.1	25	25	3430	8040
JPK50GW		50	50	0/-0.015	116	92	13	98	9	14	8.1	25	25	6080	15900



Only certified Simplicity 60 Plus Shafting provides maximum linear bearing performance.

Inch Series—page 52 Metric Series—page 90

# Linear Ball Bearings Double Wide

## Double Wide Ball Bearings – Round Flange Mount JPF-W

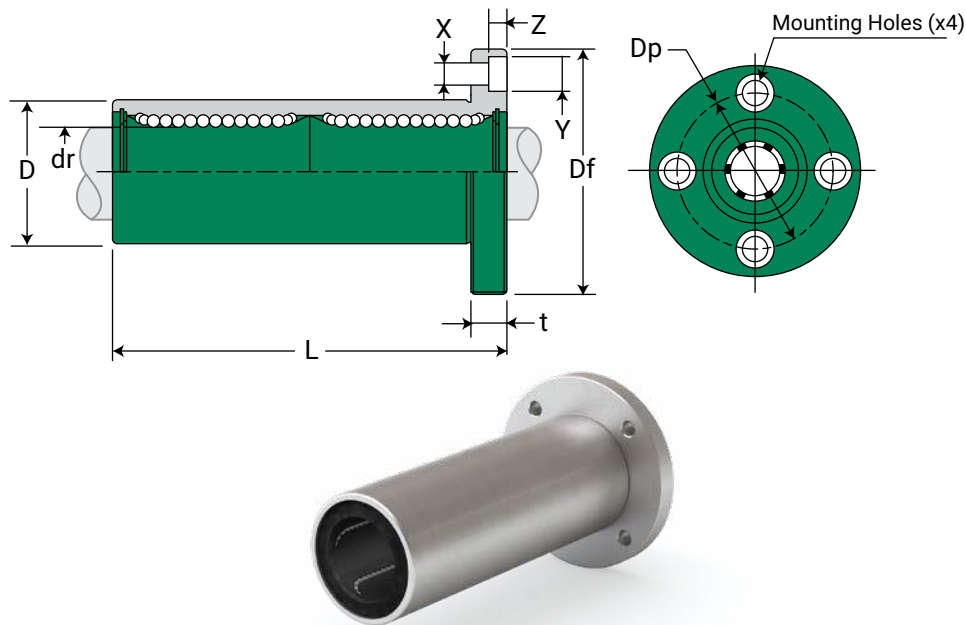

### DIMENSIONAL INFORMATION

(Standard Steel Finish)

Part No.	Nominal Shaft Diameter			Ball Circuit	Weight G	Major Dimensions & Tolerances				
	Standard Polymer Cage	Size mm	dr mm			Tolerance mm	D mm	Tolerance mm	L mm	Tolerance mm
JPF08GW		8	8	0/-0.010	4	51	15	0/-0.013	45	±0.3
JPF12GW		12	12	0/-0.010	4	110	21	0/-0.016	57	±0.3
JPF16GW		16	16	0/-0.010	5	190	28	0/-0.016	70	±0.3
JPF20GW		20	20	0/-0.010	5	260	32	0/-0.019	80	±0.3
JPF25GW		25	25	0/-0.012	6	540	40	0/-0.019	112	±0.3
JPF30GW		30	30	0/-0.012	6	680	45	0/-0.019	123	±0.3
JPF40GW		40	40	0/-0.015	6	1570	60	0/-0.022	154	±0.3
JPF50GW		50	50	0/-0.020	6	3600	80	0/-0.025	192	±0.3

Part No.	Nominal Shaft Diameter			Major Dimensions & Tolerances – Flange								Load Ratings		
	Standard Polymer Cage	Size mm	dr mm	Tolerance mm	Df mm	T mm	Dp mm	X mm	Y mm	Z mm	Eccentricity μm	Squareness μm	Dynamic C N	Static Co N
JPF08GW		8	8	0/-0.010	32	5	24	3.5	6.5	3.1	15	15	431	784
JPF12GW		12	12	0/-0.010	42	6	32	4.5	8	4.1	15	15	813	1570
JPF16GW		16	16	0/-0.010	48	6	38	4.5	8	4.1	15	15	1230	2350
JPF20GW		20	20	0/-0.010	54	8	43	5.5	9.3	5.1	20	20	1400	2740
JPF25GW		25	25	0/-0.012	62	8	51	5.5	9.3	5.1	20	20	1560	3140
JPF30GW		30	30	0/-0.012	74	10	60	6.6	11	6.1	20	20	2490	5490
JPF40GW		40	40	0/-0.015	96	13	78	9	14	8.1	25	25	3430	8040
JPF50GW		50	50	0/-0.020	116	13	98	9	14	8.1	25	25	6080	15900



Only certified Simplicity 60 Plus Shafting provides maximum linear bearing performance.

Inch Series—page 52 Metric Series—page 90

# Linear Ball Bearings Square Flange Center Mount

## Ball Bearings – Square Flange Center Mount JPKC

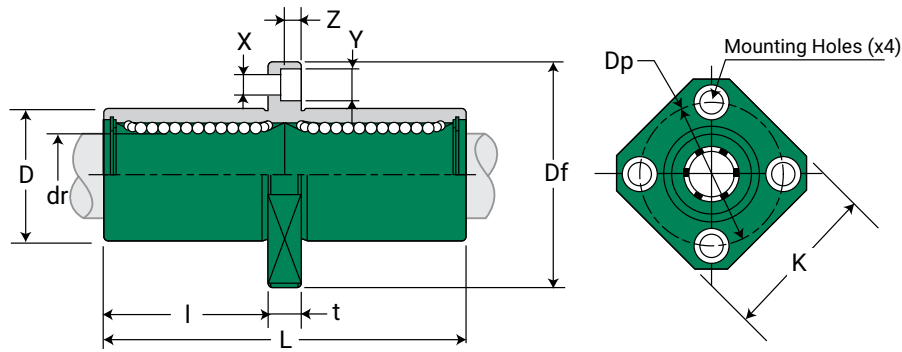

### DIMENSIONAL INFORMATION

(Standard Steel Finish)

Part No.	Nominal Shaft Diameter			Ball Circuit	Weight G	Major Dimensions & Tolerances			
	Size mm	dr mm	Tolerance $\mu\text{m}$			D mm	Tolerance $\mu\text{m}$	L mm	Tolerance $\mu\text{m}$
JPKC08G	8	8	0/-10	4	43	15	0/-13	45	$\pm 300$
JPKC12G	12	12	0/-10	4	90	21	0/-16	57	$\pm 300$
JPKC16G	16	16	0/-10	5	165	28	0/-16	70	$\pm 300$
JPKC20G	20	20	0/-12	5	225	32	0/-19	80	$\pm 300$
JPKC25G	25	25	0/-12	6	500	40	0/-19	112	$\pm 300$
JPKC30G	30	30	0/-12	6	590	45	0/-19	123	$\pm 300$
JPKC40G	40	40	0/-15	6	1380	60	0/-22	154	$\pm 300$
JPKC50G	50	50	0/-15	6	3400	80	0/-22	192	$\pm 300$

Part No.	Nominal Shaft Diameter			Major Dimensions & Tolerances – Flange										Load Ratings	
	Size mm	dr mm	Tolerance $\mu\text{m}$	l mm	Df mm	K mm	T mm	Dp mm	X mm	Y mm	Z mm	Eccentricity $\mu\text{m}$	Squareness $\mu\text{m}$	Dynamic C N	Static Co N
JPKC08G	8	8	0/-10	20	32	25	5	24	3.5	6.5	3.1	15	15	431	784
JPKC12G	12	12	0/-10	25.5	42	32	6	32	4.5	8	4.1	15	15	813	1570
JPKC16G	16	16	0/-10	32	48	37	6	38	4.5	8	4.1	15	15	1230	2350
JPKC20G	20	20	0/-12	36	54	42	8	43	5.5	9.3	5.1	20	20	1400	2740
JPKC25G	25	25	0/-12	52	62	50	8	51	5.5	9.3	5.1	20	20	1560	3140
JPKC30G	30	30	0/-12	56.5	74	58	10	60	6.6	11	6.1	20	20	2490	5490
JPKC40G	40	40	0/-15	69	96	75	13	78	9	14	8.1	25	25	3430	8040
JPKC50G	50	50	0/-15	89.5	116	92	13	98	9	14	8.1	25	25	6080	15900



Only certified Simplicity 60 Plus Shafting provides maximum linear bearing performance.

Inch Series—page 52 Metric Series—page 90

# Linear Ball Bearings Round Flange Center Mount

## Ball Bearings – Round Flange Center Mount JPFC

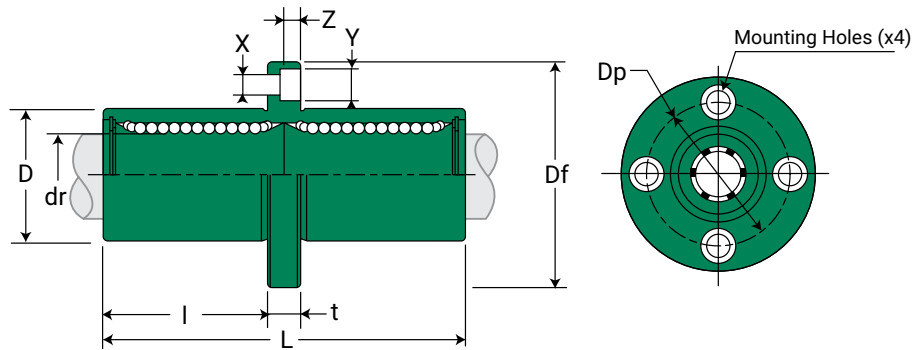

### DIMENSIONAL INFORMATION

(Standard Steel Finish)

Part No.	Nominal Shaft Diameter			Ball Circuit	Weight G	Major Dimensions & Tolerances				
	Standard Polymer Cage	Size mm	dr mm			Tolerance $\mu\text{m}$	D mm	Tolerance $\mu\text{m}$	L mm	Tolerance $\mu\text{m}$
JPFC08G		8	8	0/-10	4	51	15	0/-13	45	$\pm 300$
JPFC12G		12	12	0/-10	4	110	21	0/-16	57	$\pm 300$
JPFC16G		16	16	0/-10	5	190	28	0/-16	70	$\pm 300$
JPFC20G		20	20	0/-12	5	260	32	0/-19	80	$\pm 300$
JPFC25G		25	25	0/-12	6	540	40	0/-19	112	$\pm 300$
JPFC30G		30	30	0/-12	6	680	45	0/-19	123	$\pm 300$
JPFC40G		40	40	0/-15	6	1570	60	0/-22	154	$\pm 300$
JPFC50G		50	50	0/-15	6	3600	80	0/-22	192	$\pm 300$

Part No.	Nominal Shaft Diameter			Major Dimensions & Tolerances – Flange									Load Ratings		
	Standard Polymer Cage	Size mm	dr mm	Tolerance $\mu\text{m}$	l mm	Df mm	T mm	Dp mm	X mm	Y mm	Z mm	Eccentricity $\mu\text{m}$	Squareness $\mu\text{m}$	Dynamic C N	Static Co N
JPFC08G		8	8	0/-10	20.0	32	5	24	3.5	6.5	3.1	15	15	431	784
JPFC12G		12	12	0/-10	25.5	42	6	32	4.5	8	4.1	15	15	813	1570
JPFC16G		16	16	0/-10	32.0	48	6	38	4.5	8	4.1	15	15	1230	2350
JPFC20G		20	20	0/-12	36.0	54	8	43	5.5	9.3	5.1	20	20	1400	2740
JPFC25G		25	25	0/-12	52.0	62	8	51	5.5	9.3	5.1	20	20	1560	3140
JPFC30G		30	30	0/-12	56.5	74	10	60	6.6	11	6.1	20	20	2490	5490
JPFC40G		40	40	0/-15	69.0	96	13	78	9	14	8.1	25	25	3430	8040
JPFC50G		50	50	0/-15	89.5	116	13	98	9	14	8.1	25	25	6080	15900



Only certified Simplicity 60 Plus Shafting provides maximum linear bearing performance.

Inch Series—page 52 Metric Series—page 90

# Our Robust Collection of Simplicity Linear Slides



Built tough for heavy loads  
and harsh environments

Contact an application engineer  
to evaluate your application needs and  
receive a quote on your ideal slide solution.



# Simplicity® Linear Slides Overview

## Product Overview

Available with plain or ball bearings, Simplicity slides provide solutions in the toughest environments:

### Standard components include:

- Mounting plate
- Four pillow block assemblies
- Two steel shafts
- Two aluminum support rails
- Stainless Steel Shaft option

**Custom Solutions Available!**  
Call +1.800.962.8979

### Common Applications include:

- Fiberglass manufacturing and processing plants
- Stone cutters and other quarry applications
- Auto manufacturing facilities
- Welding and assembly lines
- Foundries
- Machine tools

Plain Bearing

Ball Bearing

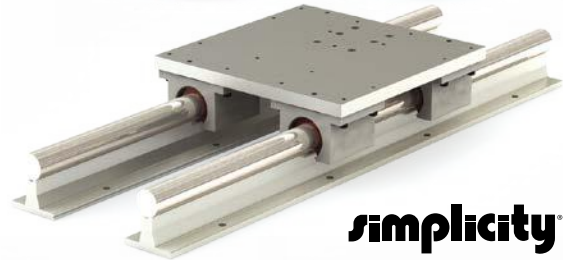

## Modular Components

- **SRB** – pre-assembled shaft, rail and bearing
- **SRB2** – support rail, guide bar, and two standard Simplicity pillow blocks
- **SRBT** – support rail, guide bar, and one standard Simplicity pillow block



SRB

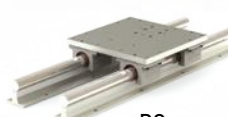

RS



RPS

## High Profile

- **RS** – comes with standard components
- **RPS** – comes with standard components and includes bottom support plate with precision alignment
- **1RPS** – same as RPS with ball screw and one end supported with end plate
- **2RPS** – same as RPS with ball screw and both ends supported with end plates

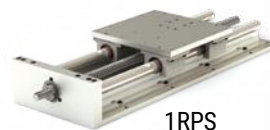

1RPS

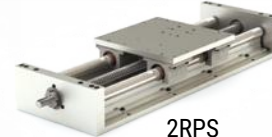

2RPS



LRPS



2LRPS

## Low Profile

- **LRPS** – low profile support rail version of a standard RPS
- **2LRPS** – low profile support rail version of a standard 2RPS

## Accessories:

- Hand crank with ball screw lock rotational lock
- Handwheel (foldaway)
- Direct drive NEMA 23 & 34 motor bracket kit
- N42, 56, and 143 bracket options available

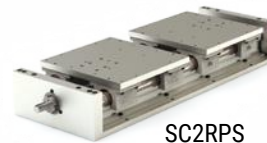

SC2RPS



2HCR & 2HWL

## 4 Lifting Points:

- On all bottom support plates for sizes 20, 24, and 32
- On bottom support plate for sizes 12 and 16 with lengths over 60 inches
- Requires 4 eyebolts of 1/2-13, not included

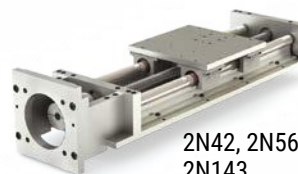
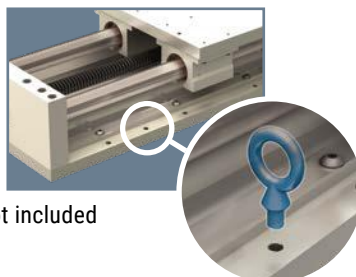

2N42, 2N56,  
2N143



2N23 & 2N34

**Only certified Simplicity 60 Plus Shafting provides maximum linear bearing performance.**

**Inch Series—page 42 Metric Series—page 80**

INCH

ISO METRIC

JIS METRIC

# Simplicity® Linear Slides Assembly

INCH

ISO METRIC

JIS METRIC

## Preassembled Shaft, Rail & Bearing SRB

### Ordering Example:

To order an assembly with a 0.750" diameter linear shaft, support rail, and one twin double sealed Simplicity bearing with FrelonGOLD®, with a rail length of 96.00", specify part number SRBTD-1200-096.000.

To order an assembly with a 0.625" diameter shaft, support rail, and two single Simplicity bearings without seals, with a rail length of 73.25", specify part number SRB2-1000-073.250.

**Note:** For lengths over 48", guide bars will be continuous, but rail supports will have a minimum of one break every 48".



## Part Number

Series	Size	L
SRBXY X XXX - 08 XX - XXX.XXX		
SRBXY X XXX - 10 XX - XXX.XXX		
SRBXY X XXX - 12 XX - XXX.XXX		
SRBXY X XXX - 16 XX - XXX.XXX		
SRBXY X XXX - 20 XX - XXX.XXX		
SRBXY X XXX - 24 XX - XXX.XXX		
SRBXY X XXX - 32 XX - XXX.XXX		



Custom Solutions Available!  
Call 800-962-8979

- ▲ Enter rail length in inches XXX.XXX (EX: 96" = 096.000)
- ▲ Shafting material:
  - 00** = Alloy Steel (Standard)
  - S3** = 316 Stainless Steel
  - S4** = 420 Stainless Steel
  - Note:** Ball bearings not suitable with ceramic coated shafting.
- ▲ Shaft diameter dimension in 1/16" increments
- ▲ Internal Lubrication:
  - No Entry** = None (Standard)
  - JKM** = Thru hole and internal felt wick
- ▲ Seals:
  - No Entry** = None
  - S** = Single Seals
  - D** = Double Seals
  - Note:** "D" double seals are included with standard ball bearings.
- ▲ Pillow Block Style:
  - 2** = Two single PN bearings
  - 3** = Three single PN bearings
  - C** = Compensated
  - T** = One Twin PWN bearing
  - T2** = Two Twin PWN bearings
  - S1** = One SST PN bearing
  - S2** = Two SST PN bearings
- ▲ Bearing Type:
  - No Entry** = Simplicity FrelonGOLD
  - E** = Simplicity Frelon® J
  - B** = Ball Bearing

## Standard Length Table

Size	Available Rail Lengths - L* (in inches)																								
08	008	012	016		020	024	028		032	036	040		044	048	052		056	060	064		068	072	076		080
10	008	012	016		020	024	028		032	036	040		044	048	052		056	060	064		068	072	076		080
12		012		018		024		030		036		042		048		054		060		066		072		078	
16		012		018		024		030		036		042		048		054		060		066		072		078	
20		012		018		024		030		036		042		048		054		060		066		072		078	
24			016			024			032		040			048			056		064			072			080
32						024			032		040			048			056		064			072			080

\*Contact factory for longer or non-standard lengths – see non-standard lengths ordering example.

# Assembly **Simplicity**® Linear Slides

## DIMENSIONAL INFORMATION

Series	Size	Linear Shaft Dia.	A	B	C	D	E <sub>T</sub>	F <sub>T</sub>	E <sub>2</sub>	F <sub>2</sub>	G	H	J	K	M	N	P	R	S
SRBXY	08	0.500	1.125	2.00	1.688	1.50	2.50	3.50	1.000	1.687	0.250	1.812	4.00	2.00	1.125	0.156	0.169	1.000	0.188
SRBXY	10	0.625	1.125	2.50	2.125	1.62	3.00	4.00	1.125	1.937	0.281	2.000	4.00	2.00	1.437	0.188	0.193	1.125	0.250
SRBXY	12	0.750	1.500	2.75	2.375	1.75	3.50	4.50	1.250	2.062	0.312	2.438	6.00	3.00	1.562	0.188	0.221	1.250	0.250
SRBXY	16	1.000	1.750	3.25	2.875	2.12	4.50	6.00	1.750	2.812	0.375	2.938	6.00	3.00	1.937	0.219	0.281	1.500	0.250
SRBXY	20	1.250	2.125	4.00	3.500	2.50	5.50	7.50	2.000	3.625	0.437	3.625	6.00	3.00	2.500	0.219	0.343	1.875	0.312
SRBXY	24	1.500	2.500	4.75	4.125	3.00	6.50	9.00	2.500	4.000	0.500	4.250	8.00	4.00	2.875	0.281	0.343	2.250	0.375
SRBXY	32	2.000	3.250	6.00	5.250	3.75	8.25	10.00	3.250	5.000	0.625	5.375	8.00	4.00	3.625	0.406	0.406	2.750	0.500

Dimensions in inches

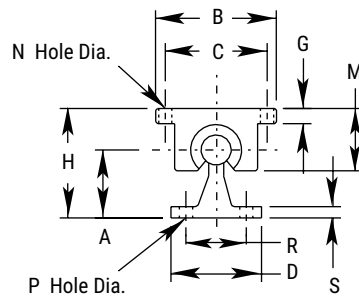
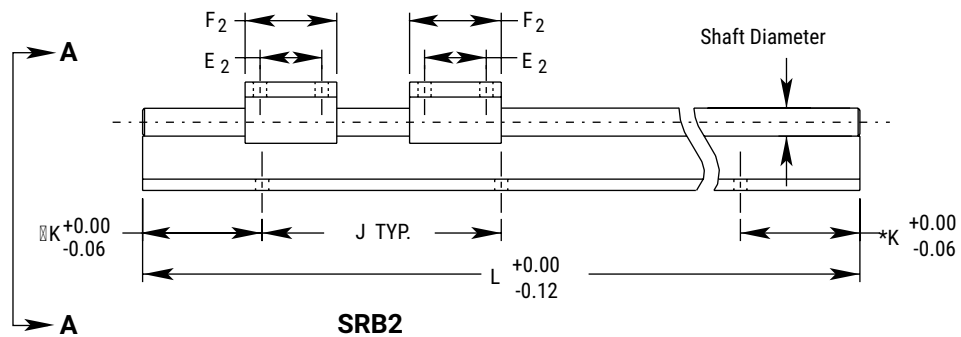
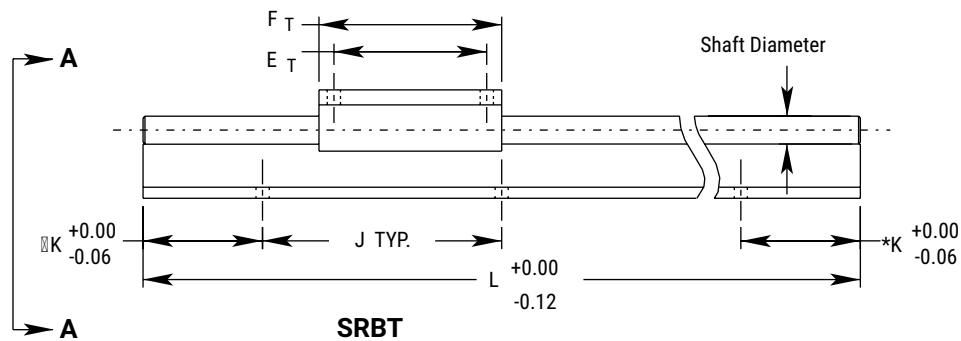

VIEW A - A

\* For standard length dimensions consult chart for "K" dimension.

\* For non-standard length dimensions "K" can be calculated with the following formula (in all cases equal on both ends).

$K(\text{non-std}) = (K(\text{from chart}) - (\Delta L/2))$ . Where  $\Delta L = \text{next longer standard length} - \text{desired length}$ .

# Simplicity® Linear Slides Rail Mounted

INCH

ISO METRIC

JIS METRIC

## Rail Mounted Slide Assembly RS

### Ordering Example:

To order a slide with a 0.625" diameter alloy steel linear shaft, Simplicity bearings with FrelonGOLD® and 28" rail length, specify part number RS-1000-028.000

Note: For lengths over 48", guide bars will be continuous, but rail supports will have a minimum of one break every 48". Lengths and mounting provisions to your specifications are available – consult factory.

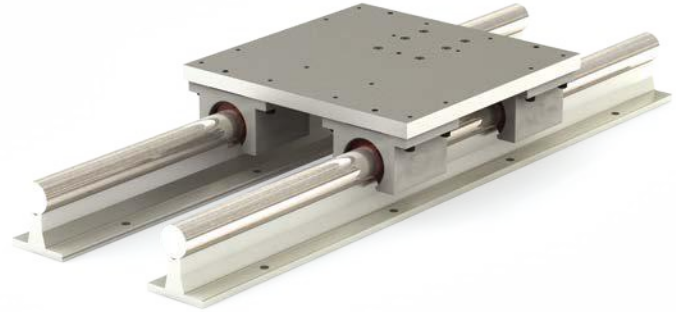

### Part Number

Series	Size	L
RS	X XXX - 08 XX - XXX.XXX	
RS	X XXX - 10 XX - XXX.XXX	
RS	X XXX - 12 XX - XXX.XXX	
RS	X XXX - 16 XX - XXX.XXX	
RS	X XXX - 20 XX - XXX.XXX	
RS	X XXX - 24 XX - XXX.XXX	
RS	X XXX - 32 XX - XXX.XXX	



Custom Solutions Available!  
Call 800-962-8979

- Enter rail length in inches XXX.XXX (EX: 28" = 028.000)
- Shafting material:
  - 00** = Alloy Steel (Standard)
  - S3** = 316 Stainless Steel
  - S4** = 420 Stainless Steel
  - Note: Ball bearings not suitable with ceramic coated shafting.
- Shaft diameter dimension in 1/16" increments
- Internal Lubrication:
  - No Entry** = None (Standard)
  - JKM** = Thru hole and internal felt wick
- Bearing Type:
  - No Entry** = Simplicity FrelonGOLD
  - E** = Simplicity Frelon® J
  - B** = Ball Bearing
- CC** = Ceramic Coated
- SS** = 440 Stainless Steel

### Standard Length Table

Size	Available Rail Lengths - L* (in inches)																													
08	008	012	016		020	024	028		032	036	040		044	048	052		056	060	064		068	072	076		080	084	088		092	096
10	008	012	016		020	024	028		032	036	040		044	048	052		056	060	064		068	072	076		080	084	088		092	096
12		012		018		024		030		036		042		048		054		060		066		072		078		084		090	096	
16		012		018		024		030		036		042		048		054		060		066		072		078		084		090	096	
20		012		018		024		030		036		042		048		054		060		066		072		078		084		090	096	
24			016			024			032		040			048			056		064			072				080		088		096
32						024			032		040			048			056		064			072				080		088		096

\*Contact factory for longer or non-standard lengths.

# Simplicity® Linear Slides Rail Mounted

## DIMENSIONAL INFORMATION

Series	Size	Linear Shaft Dia.	W	H	A	B	C	D	E	G	J	R	Tap	Hole Dia.
RS	08	0.500	6.00	2.188	1.125	2.00	3.50	1.500	0.375	5.500	4.00	1.000	10-24	0.17
RS	10	0.625	7.00	2.375	1.125	2.50	4.00	1.625	0.375	6.312	4.00	1.125	1/4-20	0.19
RS	12	0.750	8.00	2.938	1.500	2.75	4.50	1.750	0.500	7.125	6.00	1.250	1/4-20	0.22
RS	16	1.000	9.00	3.438	1.750	3.25	5.50	2.125	0.500	8.312	6.00	1.500	1/4-20	0.28
RS	20	1.250	11.00	4.375	2.125	4.00	6.50	2.500	0.750	10.000	6.00	1.875	5/16-18	0.34
RS	24	1.500	13.00	5.000	2.500	4.75	8.00	3.000	0.750	12.000	8.00	2.250	5/16-18	0.34
RS	32	2.000	18.00	6.375	3.250	6.00	10.00	3.750	1.000	15.880	8.00	2.750	3/8-16	0.41

Dimensions in inches

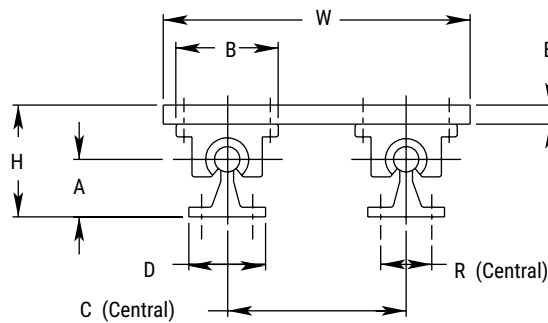
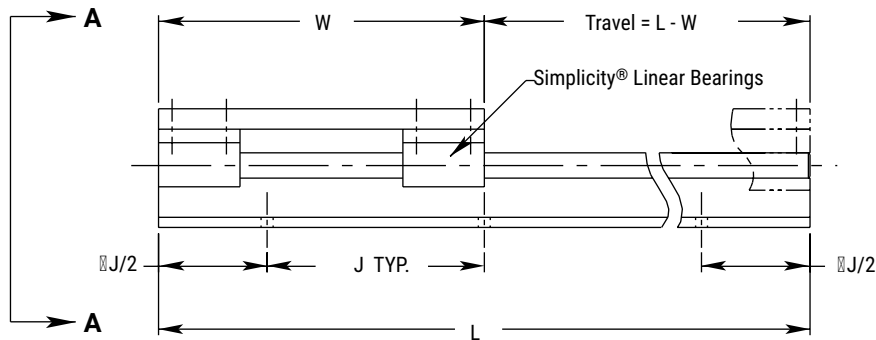
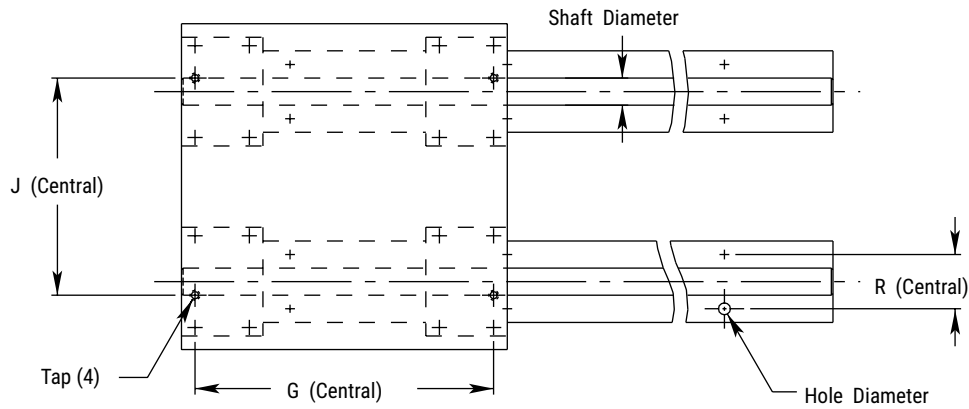

VIEW A - A

\*Hole distance to each end is equal unless specified at time of order.

INCH

ISO METRIC

JIS METRIC

# Simplicity® Linear Slides Assembly

INCH

ISO METRIC

JIS METRIC

## Rail Mounted & Plate Supported Slide Assembly RPS

### Ordering Example:

To order a slide with a 0.625" diameter alloy steel linear shaft and 28" rail length, specify part number RPS-1000-028.000

**Note:** For lengths over 48", guide bars will be continuous, but rail supports will have a minimum of one break every 48". Lengths and mounting provisions to your specifications are available – consult factory.



### Part Number

Series	Size	L
RPS X XXX - 08 XX - XXX.XXX		
RPS X XXX - 10 XX - XXX.XXX		
RPS X XXX - 12 XX - XXX.XXX		
RPS X XXX - 16 XX - XXX.XXX		
RPS X XXX - 20 XX - XXX.XXX		
RPS X XXX - 24 XX - XXX.XXX		
RPS X XXX - 32 XX - XXX.XXX		



Custom Solutions Available!  
Call 800-962-8979

- Enter rail length in inches XXX.XXX (EX: 28" = 028.000)
- Shafting material:
  - 00** = Alloy Steel (Standard)
  - S3** = 316 Stainless Steel
  - S4** = 420 Stainless Steel
  - CC** = Ceramic Coated
  - SS** = 440 Stainless Steel

**Note:** Ball bearings not suitable with ceramic coated shafting.
- Shaft diameter dimension in 1/16" increments
- Internal Lubrication:
  - No Entry** = None (Standard)
  - JKM** = Thru hole and internal felt wick
- Bearing Type:
  - No Entry** = Simplicity FrelonGOLD®
  - E** = Simplicity Frelon® J
  - B** = Ball Bearing

### Standard Length Table

Size	Available Rail Lengths - L* (in inches)																													
08	008	012	016		020	024	028		032	036	040		044	048	052		056	060	064		068	072	076		080	084	088		092	096
10	008	012	016		020	024	028		032	036	040		044	048	052		056	060	064		068	072	076		080	084	088		092	096
12		012		018		024		030		036		042		048		054		060		066		072		078		084		090		096
16		012		018		024		030		036		042		048		054		060		066		072		078		084		090		096
20		012		018		024		030		036		042		048		054		060		066		072		078		084		090		096
24			016			024			032		040			048			056		064			072				080		088		096
32						024			032		040			048			056		064			072				080		088		096

\*Contact factory for longer or non-standard lengths.

# Simplicity® Linear Slides Assembly

## DIMENSIONAL INFORMATION

Series	Size	Linear Shaft Dia.	W	H	A	B	C	D	E	F	G	J	Tap	Hole Dia.
RPS	08	0.500	6.00	2.562	1.125	2.00	3.50	1.500	0.375	1.00	5.500	4.00	10-24	0.22
RPS	10	0.625	7.00	2.750	1.125	2.50	4.00	1.625	0.375	1.00	6.312	4.00	1/4-20	0.28
RPS	12	0.750	8.00	3.438	1.500	2.75	4.50	1.750	0.500	1.25	7.125	6.00	1/4-20	0.28
RPS	16	1.000	9.00	3.938	1.750	3.25	5.50	2.125	0.500	1.25	8.312	6.00	1/4-20	0.28
RPS	20	1.250	11.00	5.125	2.125	4.00	6.50	2.500	0.750	1.50	10.000	6.00	5/16-18	0.34
RPS	24	1.500	13.00	5.750	2.500	4.75	8.00	3.000	0.750	1.50	12.000	8.00	5/16-18	0.34
RPS	32	2.000	18.00	7.375	3.250	6.00	10.00	3.750	1.000	1.75	15.875	8.00	3/8-16	0.41

Dimensions in inches

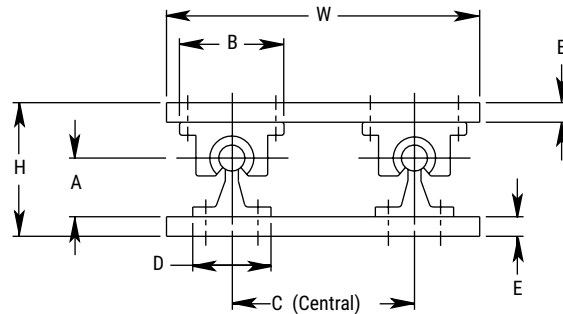
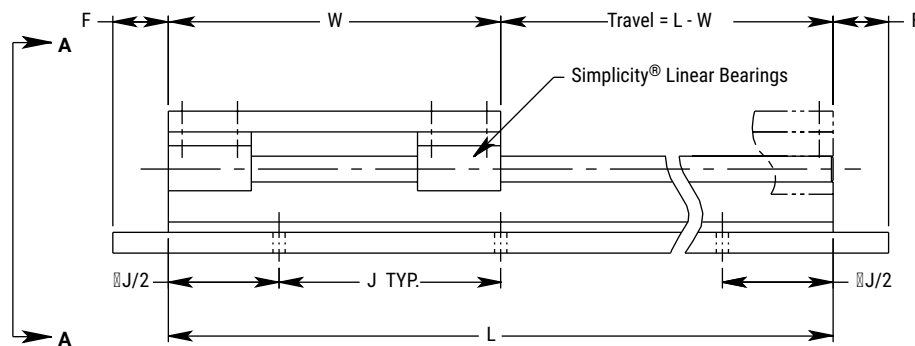
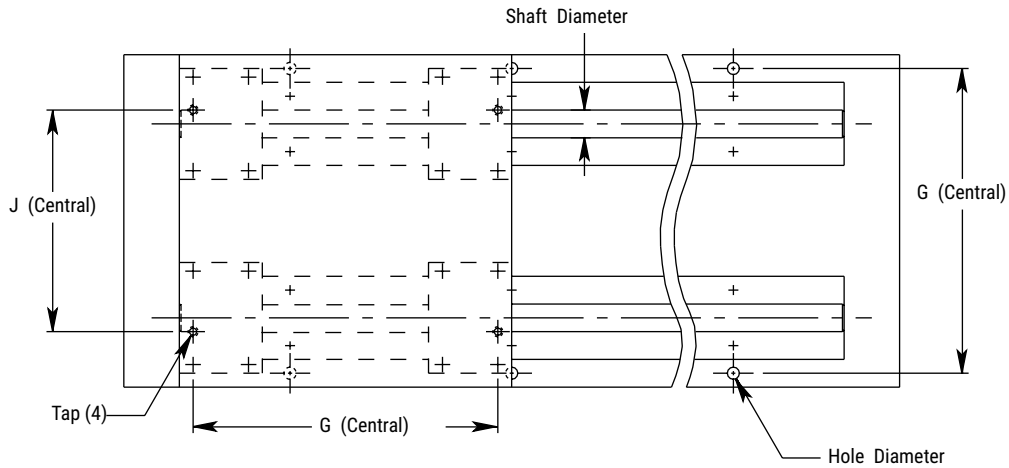

VIEW A - A

\*Hole distance to each end is equal unless specified at time of order.

# Simplicity® Linear Slides One End Support

INCH

ISO METRIC

JIS METRIC

## Rail Mounted & Plate Supported – Ball Screw Driven 1RPS SUPPORTED ON ONE END

### Ordering Example:

To order a slide with a 0.625" diameter 440 stainless steel linear shaft, 28" rail length, 0.200" right hand select ball screw, specify part number 1RPS-10SS-028.000-AA7R.

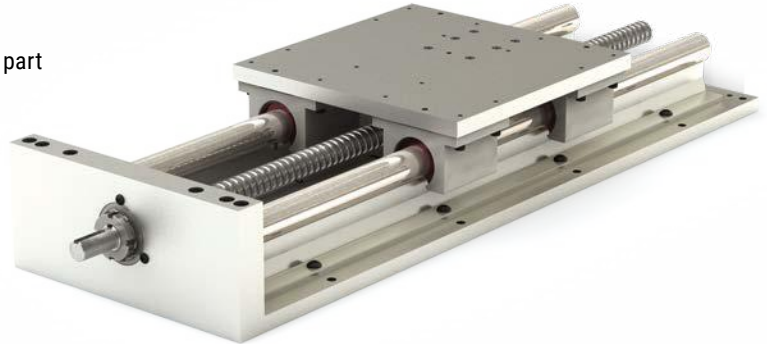

### Part Number

Series	Size	L	Lead
1RPS X XXX - 08 XX - XXX.XXX - YYYY			
1RPS X XXX - 10 XX - XXX.XXX - YYYY			
1RPS X XXX - 12 XX - XXX.XXX - YYYY			
1RPS X XXX - 16 XX - XXX.XXX - YYYY			
1RPS X XXX - 20 XX - XXX.XXX - YYYY			
1RPS X XXX - 24 XX - XXX.XXX - YYYY			
1RPS X XXX - 32 XX - XXX.XXX - YYYY			

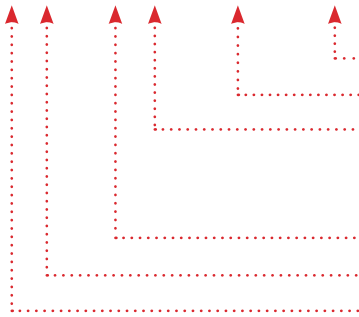

Substitute standard or select lead code from table for "YYYY"

Enter rail length in inches XXX.XXX (EX: 28" = 028.000)

Shafting material: **00** = Alloy Steel (Standard)      **CC** = Ceramic Coated  
**S3** = 316 Stainless Steel      **SS** = 440 Stainless Steel  
**S4** = 420 Stainless Steel  
 Note: Ball bearings not suitable with ceramic coated shafting.

Shaft diameter dimension in 1/16" increments

Internal Lubrication: **No Entry** = None (Standard)      **JKM** = Thru hole and internal felt wick

Bearing Type: **No Entry** = Simplicity FrelonGOLD®      **E** = Simplicity Frelon® J  
**B** = Ball Bearing

### Standard Lead Table

Accurate to less than 0.007" per foot accumulative

Size	Available Lead Codes					
08	AAXR	AAXL				
10	AAXR	AAXL				
12	AAXR	AAXL				
16			ABXR	ABXL	ACXR	ADXR
20			ABXR	ABXL	ACXR	ADXR
24			ABXR	ABXL	ACXR	ADXR
32			ABXR	ABXL	ACXR	ADXR

AAXR = 0.20 Right Hand  
 AAXL = 0.20 Left Hand  
 ABXR = 0.25 Right Hand  
 ABXL = 0.25 Left Hand  
 ACXR = 0.50 Right Hand  
 ADXR = 1.00 Right Hand  
 ADXL = 1.00 Left Hand

Note: Additional leads available upon request.

### Select Lead Table

Accurate to less than 0.003" per foot accumulative

Size	Available Lead Codes					
08	AA7R	AA7L				
10	AA7R	AA7L				
12	AA7R	AA7L				
16			AB7R	AB7L	AC7R	AD7R
20			AB7R	AB7L	AC7R	AD7R
24			AB7R	AB7L	AC7R	AD7R
32			AB7R	AB7L	AC7R	AD7R

AA7R = 0.20 Right Hand  
 AA7L = 0.20 Left Hand  
 AB7R = 0.25 Right Hand  
 AB7L = 0.25 Left Hand  
 AC7R = 0.50 Right Hand  
 AD7R = 1.00 Right Hand  
 AD7L = 1.00 Left Hand

Note: Additional leads available upon request.

### Standard Length Table

Size	Available Rail Lengths – L* (in inches)									
08	008	012	016		020	024	028		032	
10	008	012	016		020	024	028		032	
12		012		018		024		030		036
16		012		018		024		030		036
20		012		018		024		030		036
24			016			024			032	040
32						024			032	040

\*Contact factory for longer or non-standard lengths.



Custom Solutions Available!  
 Call 800-962-8979

# One End Support **Simplicity**® Linear Slides

## DIMENSIONAL INFORMATION

Series	Size	Linear Shaft Dia.	W	H	A	B	C	D	E	F	G	J	K	M	N	O	Tap	Hole Dia.	Key
1RPS	08	0.500	6.00	2.562	1.125	2.00	3.50	1.500	0.375	1.00	5.500	4.00	1.375	0.375	1.45	0.63	10-24	0.22	3/32 sq x 5/8 lg
1RPS	10	0.625	7.00	2.750	1.125	2.50	4.00	1.625	0.375	1.00	6.312	4.00	1.375	0.375	1.45	0.63	1/4-20	0.28	3/32 sq x 5/8 lg
1RPS	12	0.750	8.00	3.438	1.500	2.75	4.50	1.750	0.500	1.25	7.125	6.00	1.500	0.375	1.45	0.63	1/4-20	0.28	3/32 sq x 5/8 lg
1RPS	16	1.000	9.00	3.938	1.750	3.25	5.50	2.125	0.500	1.25	8.312	6.00	2.125	0.625	1.76	1.00	1/4-20	0.28	3/16 sq x 1" lg
1RPS	20	1.250	11.00	5.125	2.125	4.00	6.50	2.500	0.750	1.50	10.000	6.00	2.375	0.625	1.76	1.00	5/16-18	0.34	3/16 sq x 1" lg
1RPS	24	1.500	13.00	5.750	2.500	4.75	8.00	3.000	0.750	1.50	12.000	8.00	2.875	0.875	2.31	1.50	5/16-18	0.34	1/4 sq x 1.62 lg
1RPS	32	2.000	18.00	7.375	3.250	6.00	10.00	3.750	1.000	1.75	15.875	8.00	3.875	0.875	2.31	1.50	3/8-16	0.41	1/4 sq x 1.62 lg

Dimensions in inches

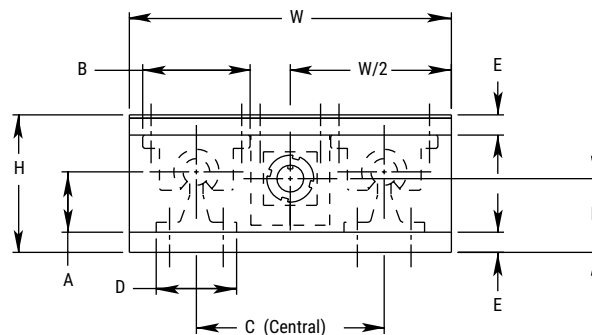
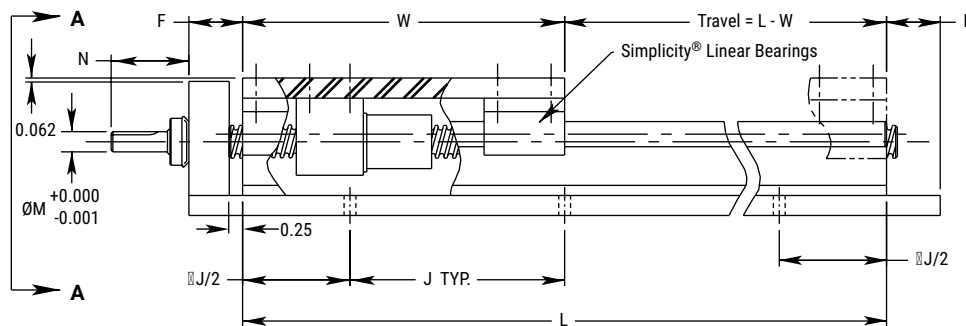
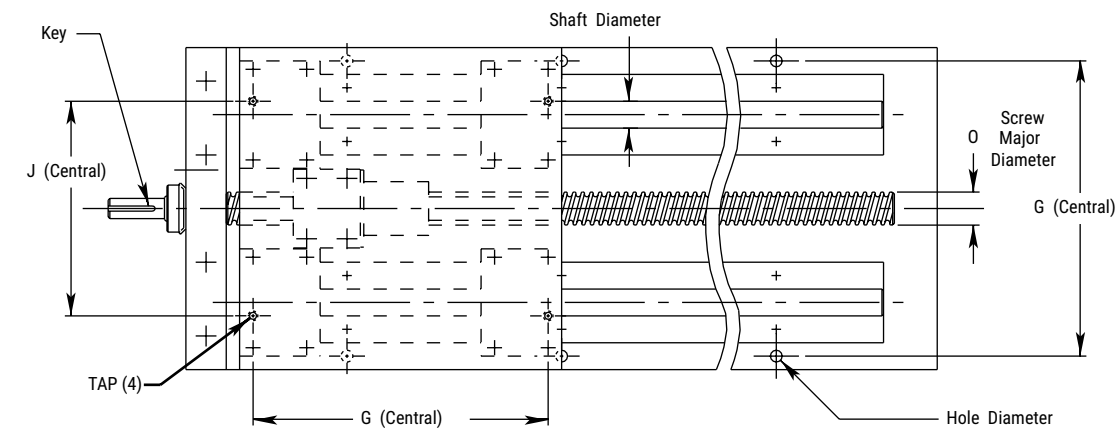

VIEW A - A

\*Hole distance to each end is equal unless specified at time of order.

# Simplicity® Linear Slides Both Ends Supported

INCH

ISO METRIC

JIS METRIC

## Rail Mounted & Plate Supported – Ball Screw Driven 2RPS SUPPORTED ON BOTH ENDS

### Ordering Example:

To order a slide with a 0.625" diameter alloy steel linear shaft, 28" rail length, 0.200" right hand select ball screw, specify part number 2RPS-1000-028.000-AA7R.



### Part Number

Series	Size	L	Lead
2RPS X XXX - 08 XX - XXX.XXX - YYYY			
2RPS X XXX - 10 XX - XXX.XXX - YYYY			
2RPS X XXX - 12 XX - XXX.XXX - YYYY			
2RPS X XXX - 16 XX - XXX.XXX - YYYY			
2RPS X XXX - 20 XX - XXX.XXX - YYYY			
2RPS X XXX - 24 XX - XXX.XXX - YYYY			
2RPS X XXX - 32 XX - XXX.XXX - YYYY			

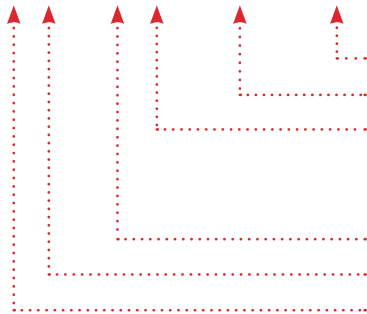

Substitute standard or select lead code from table for "YYYY"

Enter rail length in inches XXX.XXX (EX: 28" = 028.000)

Shafting material: **00** = Alloy Steel (Standard) **CC** = Ceramic Coated  
**S3** = 316 Stainless Steel **SS** = 440 Stainless Steel  
**S4** = 420 Stainless Steel  
**Note:** Ball bearings not suitable with ceramic coated shafting.

Shaft diameter dimension in 1/16" increments

Internal Lubrication: **No Entry** = None (Standard) **JKM** = Thru hole and internal felt wick

Bearing Type: **No Entry** = Simplicity FrelonGOLD® **E** = Simplicity Frelon® J  
**B** = Ball Bearing

### Standard Lead Table

Accurate to less than 0.007" per foot accumulative

Size	Available Lead Codes					
08	AAXR	AAXL				
10	AAXR	AAXL				
12	AAXR	AAXL				
16			ABXR	ABXL	ACXR	ADXR
20			ABXR	ABXL	ACXR	ADXR
24			ABXR	ABXL	ACXR	ADXR
32			ABXR	ABXL	ACXR	ADXR

AAXR = 0.20 Right Hand  
AAXL = 0.20 Left Hand  
ABXR = 0.25 Right Hand  
ABXL = 0.25 Left Hand  
ACXR = 0.50 Right Hand  
ADXR = 1.00 Right Hand  
ADXL = 1.00 Left Hand

**Note:** Additional leads available upon request.

### Select Lead Table

Accurate to less than 0.003" per foot accumulative

Size	Available Lead Codes					
08	AA7R	AA7L				
10	AA7R	AA7L				
12	AA7R	AA7L				
16			AB7R	AB7L	AC7R	AD7R
20			AB7R	AB7L	AC7R	AD7R
24			AB7R	AB7L	AC7R	AD7R
32			AB7R	AB7L	AC7R	AD7R

AA7R = 0.20 Right Hand  
AA7L = 0.20 Left Hand  
AB7R = 0.25 Right Hand  
AB7L = 0.25 Left Hand  
AC7R = 0.50 Right Hand  
AD7R = 1.00 Right Hand  
AD7L = 1.00 Left Hand

**Note:** Additional leads available upon request.

### Standard Length Table

Size	Available Rail Lengths - L * (in inches)																													
08	008	012	016		020	024	028		032	036	040		044	048	052		056	060	064		068	072	076		080	084	088		092	096
10	008	012	016		020	024	028		032	036	040		044	048	052		056	060	064		068	072	076		080	084	088		092	096
12		012		018		024		030		036		042		048		054		060		066		072		078		084		090	096	
16		012		018		024		030		036		042		048		054		060		066		072		078		084		090	096	
20		012		018		024		030		036		042		048		054		060		066		072		078		084		090	096	
24			016			024			032		040			048			056		064			072			080		088		096	
32						024			032		040			048			056		064			072			080		088		096	

\*Contact factory for longer or non-standard lengths.

# Simplicity® Linear Slides Both Ends Supported

## DIMENSIONAL INFORMATION

Series	Size	Linear Shaft Dia.	W	H	A	B	C	D	E	F	G	J	K	M	N	O	Tap	Hole Dia.	Key
2RPS	08	0.500	6.00	2.562	1.125	2.00	3.50	1.500	0.375	1.00	5.500	4.00	1.375	0.375	1.45	0.63	10-24	0.22	3/32 sq x 5/8 lg
2RPS	10	0.625	7.00	2.750	1.125	2.50	4.00	1.625	0.375	1.00	6.312	4.00	1.375	0.375	1.45	0.63	1/4-20	0.28	3/32 sq x 5/8 lg
2RPS	12	0.750	8.00	3.438	1.500	2.75	4.50	1.750	0.500	1.25	7.125	6.00	1.500	0.375	1.45	0.63	1/4-20	0.28	3/32 sq x 5/8 lg
2RPS	16	1.000	9.00	3.938	1.750	3.25	5.50	2.125	0.500	1.25	8.312	6.00	2.125	0.625	1.76	1.00	1/4-20	0.28	3/16 sq x 1" lg
2RPS	20	1.250	11.00	5.125	2.125	4.00	6.50	2.500	0.750	1.50	10.000	6.00	2.375	0.625	1.76	1.00	5/16-18	0.34	3/16 sq x 1" lg
2RPS	24	1.500	13.00	5.750	2.500	4.75	8.00	3.000	0.750	1.50	12.000	8.00	2.875	0.875	2.31	1.50	5/16-18	0.34	1/4 sq x 1.62 lg
2RPS	32	2.000	18.00	7.375	3.250	6.00	10.00	3.750	1.000	1.75	15.875	8.00	3.875	0.875	2.31	1.50	3/8-16	0.41	1/4 sq x 1.62 lg

Dimensions in inches

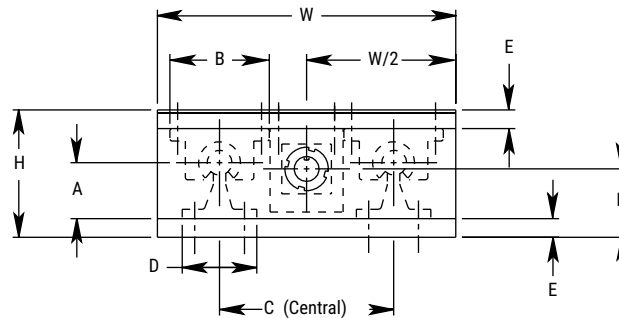
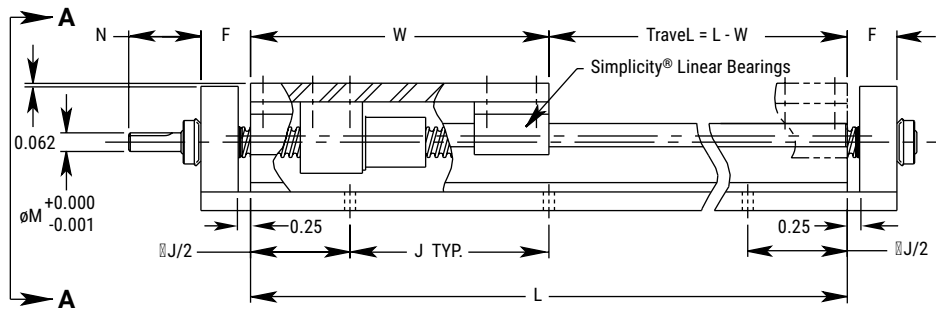
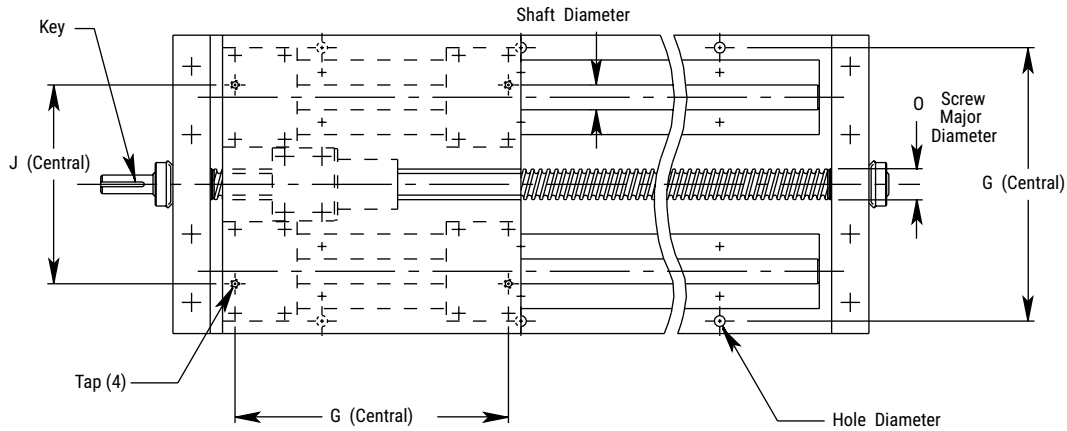

VIEW A - A

\*Hole distance to each end is equal unless specified at time of order.

# Simplicity® Linear Slides Low Profile

INCH

ISO METRIC

JIS METRIC

## Rail Mounted & Plate Supported Slide Assembly LRPS

### LOW PROFILE

#### Ordering Example:

To order a slide with a 0.625" diameter alloy steel linear shaft and 28" rail length, specify part number LRPS-1000-028.000.

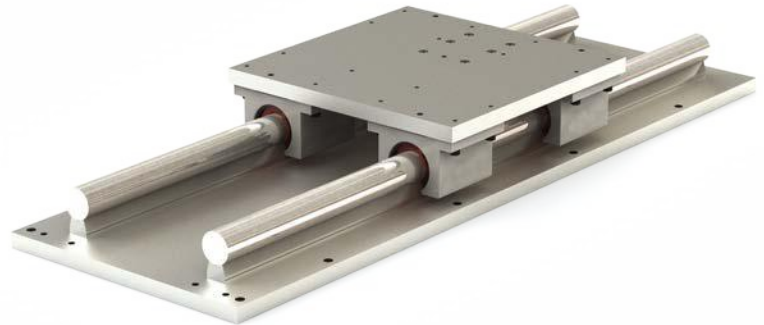

#### Part Number

Series	Size	L
LRPS X XXX - 08 XX - XXX.XXX		
LRPS X XXX - 10 XX - XXX.XXX		
LRPS X XXX - 12 XX - XXX.XXX		
LRPS X XXX - 16 XX - XXX.XXX		
LRPS X XXX - 20 XX - XXX.XXX		
LRPS X XXX - 24 XX - XXX.XXX		
LRPS X XXX - 32 XX - XXX.XXX		



Custom Solutions Available!  
Call 800-962-8979

- Enter rail length in inches XXX.XXX (EX: 28" = 028.000)
  - Shafting material:
    - 00** = Alloy Steel (Standard)
    - S3** = 316 Stainless Steel
    - S4** = 420 Stainless Steel
    - CC** = Ceramic Coated
    - SS** = 440 Stainless Steel
  - Shaft diameter dimension in 1/16" increments
  - Internal Lubrication:
    - No Entry** = None (Standard)
    - JKM** = Thru hole and internal felt wick
  - Bearing Type:
    - No Entry** = Simplicity FrelonGOLD®
    - E** = Simplicity Frelon® J
    - B** = Ball Bearing
- Note: Ball bearings not suitable with ceramic coated shafting.*

#### Standard Length Table

Size	Available Rail Lengths - L* (in inches)																													
08	008	012	016		020	024	028		032	036	040		044	048	052		056	060	064		068	072	076		080	084	088		092	096
10	008	012	016		020	024	028		032	036	040		044	048	052		056	060	064		068	072	076		080	084	088		092	096
12		012		018		024		030		036		042		048		054		060		066		072		078		084		090		096
16		012		018		024		030		036		042		048		054		060		066		072		078		084		090		096
20		012		018		024		030		036		042		048		054		060		066		072		078		084		090		096
24			016			024			032		040			048			056		064			072			080		088			096
32						024			032		040			048			056		064			072			080		088			096

\*Contact factory for longer or non-standard lengths.

# Simplicity® Linear Slides Low Profile

## DIMENSIONAL INFORMATION

Series	Size	Linear Shaft Dia.	W	H	A	B	C	D	E	F	G	J	Tap	Hole Dia.
LRPS	08	0.500	6.00	2.000	0.563	2.00	3.50	0.37	0.375	1.00	5.500	4.00	10-24	0.22
LRPS	10	0.625	7.00	2.313	0.688	2.50	4.00	0.45	0.375	1.00	6.312	4.00	1/4-20	0.28
LRPS	12	0.750	8.00	2.688	0.750	2.75	4.50	0.51	0.500	1.25	7.125	6.00	1/4-20	0.28
LRPS	16	1.000	9.00	3.188	1.000	3.25	5.50	0.69	0.500	1.25	8.312	6.00	1/4-20	0.28
LRPS	20	1.250	11.00	4.188	1.188	4.00	6.50	0.78	0.750	1.50	10.000	6.00	5/16-18	0.34
LRPS	24	1.500	13.00	4.625	1.375	4.75	8.00	0.93	0.750	1.50	12.000	8.00	5/16-18	0.34
LRPS	32	2.000	18.00	5.875	1.750	6.00	10.00	1.18	1.000	1.75	15.875	8.00	3/8-16	0.41

Dimensions in inches

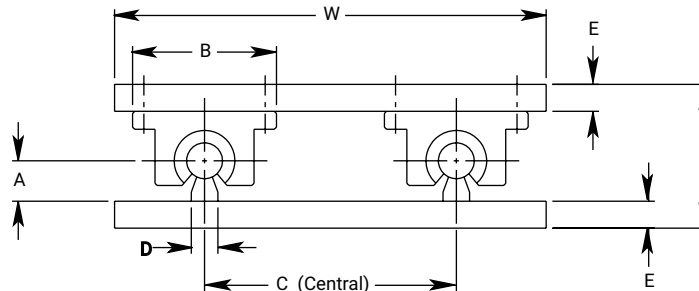
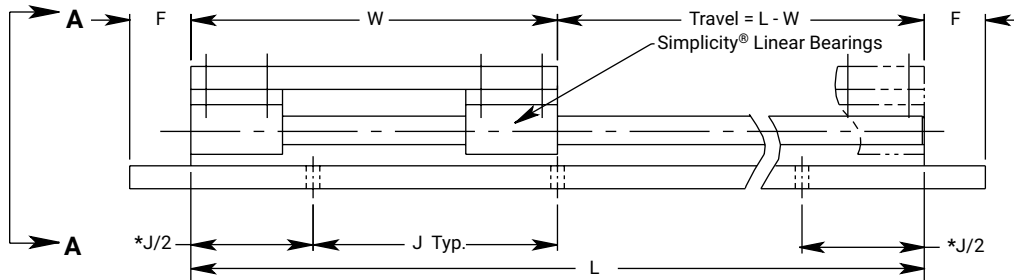
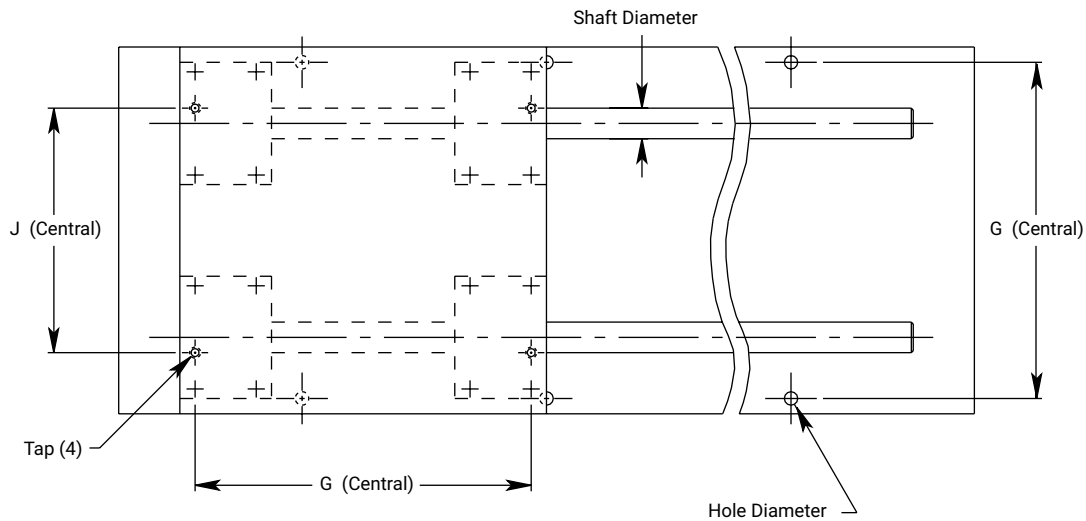

View A - A

\*Hole distance to each end is equal unless specified at time of order.

INCH

ISO METRIC

JIS METRIC

# Simplicity® Linear Slides Low Profile Ball Screw

INCH

ISO METRIC

JIS METRIC

## Rail Mounted & Plate Ball Screw Driven 2LRPS

LOW PROFILE – SUPPORTED ON BOTH ENDS

### Ordering Example:

To order a slide with a 0.625" diameter alloy steel linear shaft, 28" rail length, 0.200" right hand select ball screw – specify part number, 2LRPS-1000-028.000-AA7R.

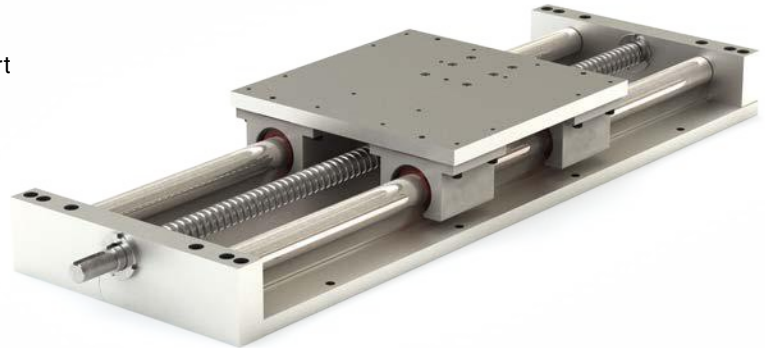

### Part Number

Series	Size	L	Lead
2LRPS X XXX - 08 XX - XXX.XXX - YYYY			
2LRPS X XXX - 10 XX - XXX.XXX - YYYY			
2LRPS X XXX - 12 XX - XXX.XXX - YYYY			
2LRPS X XXX - 16 XX - XXX.XXX - YYYY			
2LRPS X XXX - 20 XX - XXX.XXX - YYYY			
2LRPS X XXX - 24 XX - XXX.XXX - YYYY			
2LRPS X XXX - 32 XX - XXX.XXX - YYYY			

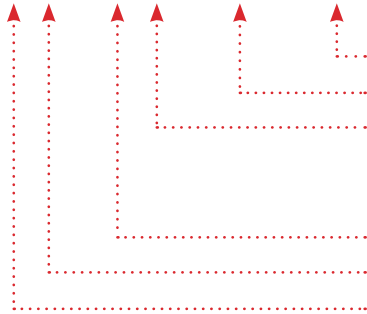

Substitute standard or select lead code from table for "YYYY"

Enter rail length in inches XXX.XXX (EX: 28" = 028.000)

Shafting material: **00** = Alloy Steel (Standard) **CC** = Ceramic Coated  
**S3** = 316 Stainless Steel **SS** = 440 Stainless Steel  
**S4** = 420 Stainless Steel  
**Note:** Ball bearings not suitable with ceramic coated shafting.

Shaft diameter dimension in 1/16" increments

Internal Lubrication: **No Entry** = None (Standard) **JKM** = Thru hole and internal felt wick

Bearing Type: **No Entry** = Simplicity FrelonGOLD® **E** = Simplicity Frelon®J  
**B** = Ball Bearing

### Standard Lead Table

Accurate to less than 0.007" per foot accumulative

Size	Available Lead Codes					
08	AAXR	AAXL				
10	AAXR	AAXL				
12	AAXR	AAXL				
16			ABXR	ABXL	ACXR	ADXR
20			ABXR	ABXL	ACXR	ADXR
24			ABXR	ABXL	ACXR	ADXR
32			ABXR	ABXL	ACXR	ADXR

AAXR = 0.20 Right Hand  
 AAXL = 0.20 Left Hand  
 ABXR = 0.25 Right Hand  
 ABXL = 0.25 Left Hand  
 ACXR = 0.50 Right Hand  
 ADXR = 1.00 Right Hand  
 ADXL = 1.00 Left Hand

**Note:** Additional leads available upon request.

### Select Lead Table

Accurate to less than 0.003" per foot accumulative

Size	Available Lead Codes					
08	AA7R	AA7L				
10	AA7R	AA7L				
12	AA7R	AA7L				
16			AB7R	AB7L	AC7R	AD7R
20			AB7R	AB7L	AC7R	AD7R
24			AB7R	AB7L	AC7R	AD7R
32			AB7R	AB7L	AC7R	AD7R

AA7R = 0.20 Right Hand  
 AA7L = 0.20 Left Hand  
 AB7R = 0.25 Right Hand  
 AB7L = 0.25 Left Hand  
 AC7R = 0.50 Right Hand  
 AD7R = 1.00 Right Hand  
 AD7L = 1.00 Left Hand

**Note:** Additional leads available upon request.

### Standard Length Table

Size	Available Rail Lengths – L* (in inches)																													
08	008	012	016		020	024	028		032	036	040		044	048	052		056	060	064		068	072	076		080	084	088		092	096
10	008	012	016		020	024	028		032	036	040		044	048	052		056	060	064		068	072	076		080	084	088		092	096
12		012		018		024		030		036		042		048		054		060		066		072		078		084		090		096
16		012		018		024		030		036		042		048		054		060		066		072		078		084		090		096
20		012		018		024		030		036		042		048		054		060		066		072		078		084		090		096
24			016			024			032		040			048			056		064			072			080		088			096
32						024			032		040			048			056		064			072			080		088			096

\*Contact factory for longer or non-standard lengths.

# Simplicity® Linear Slides Low Profile Ball Screw

## DIMENSIONAL INFORMATION

Series	Size	Linear Shaft Dia.	W	H	A	B	C	D	E	F	G	J	K	M	N	O	Tap	Hole Dia.	Key
2LRPS	08	0.500	6.00	2.000	0.563	2.00	3.50	0.37	0.375	1.00	5.500	4.00	1.000	0.375	1.45	0.63	10-24	0.22	3/32 sq x 5/8 lg
2LRPS	10	0.625	7.00	2.313	0.688	2.50	4.00	0.45	0.375	1.00	6.312	4.00	1.156	0.375	1.45	0.63	1/4-20	0.28	3/32 sq x 5/8 lg
2LRPS	12	0.750	8.00	2.688	0.750	2.75	4.50	0.51	0.500	1.25	7.125	6.00	1.344	0.375	1.45	0.63	1/4-20	0.28	3/32 sq x 5/8 lg
2LRPS	16	1.000	9.00	3.188	1.000	3.25	5.50	0.69	0.500	1.25	8.312	6.00	1.594	0.625	1.76	1.00	1/4-20	0.28	3/16 sq x 1" lg
2LRPS	20	1.250	11.00	4.188	1.188	4.00	6.50	0.78	0.750	1.50	10.000	6.00	2.094	0.625	1.76	1.00	5/16-18	0.34	3/16 sq x 1" lg
2LRPS	24	1.500	13.00	4.625	1.375	4.75	8.00	0.93	0.750	1.50	12.000	8.00	2.312	0.875	2.31	1.50	5/16-18	0.34	1/4 sq x 1.62 lg
2LRPS	32	2.000	18.00	5.875	1.750	6.00	10.00	1.18	1.000	1.75	15.875	8.00	2.937	0.875	2.31	1.50	3/8-16	0.41	1/4 sq x 1.62 lg

Dimensions in inches

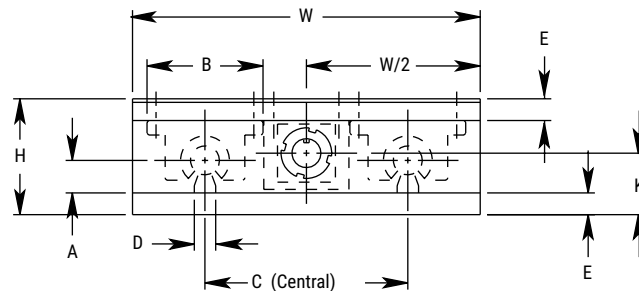
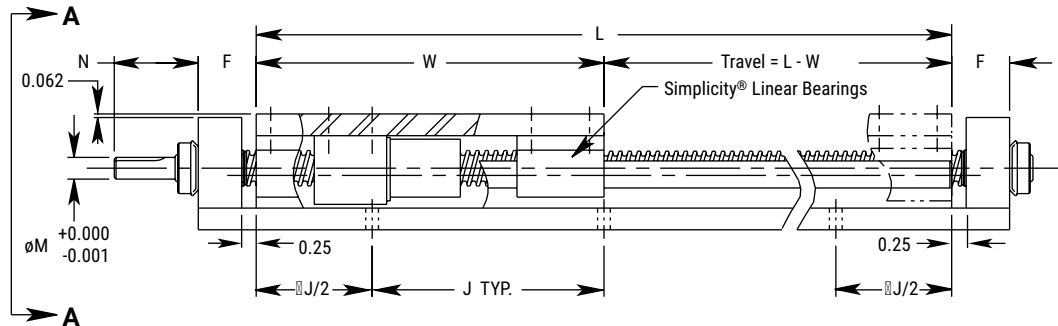
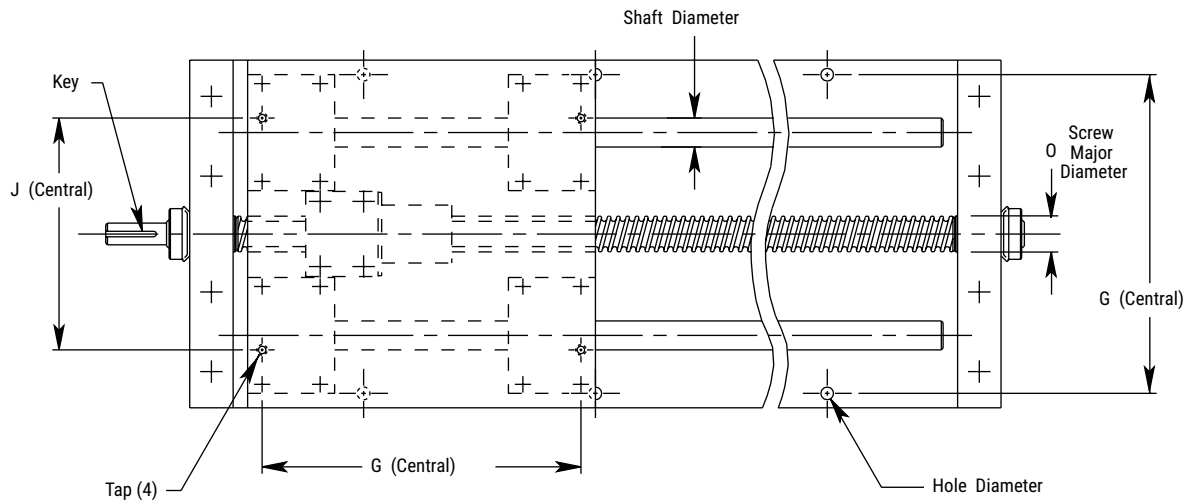

VIEW A - A

\*Hole distance to each end is equal unless specified at time of order.

INCH

ISO METRIC

JIS METRIC

# Simplicity® Linear Slides Self Centering

INCH

ISO METRIC

JIS METRIC

## Self-Centering Slide Assembly SC2RPS

### Ordering Example:

To order a slide with a 0.625" diameter alloy steel linear shaft, 56" rail length, 0.200" right hand select lead screw – specify part number, SC2RPS-1000-056.000-AA7LR.



### Part Number

Series	Size	L	Lead
SC2RPS X XXX - 08 XX - XXX.XXX - YYYYY			
SC2RPS X XXX - 10 XX - XXX.XXX - YYYYY			
SC2RPS X XXX - 12 XX - XXX.XXX - YYYYY			
SC2RPS X XXX - 16 XX - XXX.XXX - YYYYY			
SC2RPS X XXX - 20 XX - XXX.XXX - YYYYY			
SC2RPS X XXX - 24 XX - XXX.XXX - YYYYY			
SC2RPS X XXX - 32 XX - XXX.XXX - YYYYY			

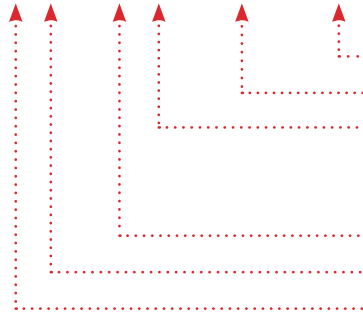

Substitute standard or select lead code from table for "YYYY"

Enter rail length in inches XXX.XXX (EX: 28" = 028.000)

Shafting material: **00** = Alloy Steel (Standard) **CC** = Ceramic Coated  
**S3** = 316 Stainless Steel **SS** = 440 Stainless Steel  
**S4** = 420 Stainless Steel  
**Note:** Ball bearings not suitable with ceramic coated shafting.

Shaft diameter dimension in 1/16" increments

Internal Lubrication: **No Entry** = None (Standard) **JKM** = Thru hole and internal felt wick

Bearing Type: **No Entry** = Simplicity FrelonGOLD® **E** = Simplicity Frelon® J  
**B** = Ball Bearing

### Standard Lead Table

Accurate to less than 0.007" per foot accumulative

Size	Available Lead Codes	
08	AAXLR	
10	AAXLR	
12	AAXLR	
16	ABXLR	
20	ABXLR	
24	ABXLR	ADXLR
32	ABXLR	ADXLR

AAXLR = 0.20 Leads  
 ABXLR = 0.25 Leads  
 ADXLR = 1.00 Leads

One left and one right hand lead ballscrew on each self-centering slide assembly.

**Note:** Additional leads available upon request.

### Select Lead Table

Accurate to less than 0.003" per foot accumulative

Size	Available Lead Codes	
08	AA7LR	
10	AA7LR	
12	AA7LR	
16	AB7LR	
20	AB7LR	
24	AB7LR	AD7LR
32	AB7LR	AD7LR

AA7LR = 0.20 Leads  
 AB7LR = 0.25 Leads  
 AD7LR = 1.00 Leads

One left and one right hand lead ballscrew on each self-centering slide assembly.

**Note:** Additional leads available upon request.

### Standard Length Table

Size	Available Rail Lengths - L* (in inches)																				
08	016	020	024	028	032	036	040	044	048	052	056	060	064	068	072	076	080	084	088	092	096
10	016	020	024	028	032	036	040	044	048	052	056	060	064	068	072	076	080	084	088	092	096
12		018	024	030	036	042	048	054	060	066	072	078	084	090	096						
16			024	030	036	042	048	054	060	066	072	078	084	090	096						
20			024	030	036	042	048	054	060	066	072	078	084	090	096						
24					032	040	048	056	064	072	080	088	096								
32						040	048	056	064	072	080	088	096								

\*Contact factory for longer or non-standard lengths.

# Simplicity® Linear Slides Self Centering

## DIMENSIONAL INFORMATION

Series	Size	Linear Shaft Dia.	W	H	A	B	C	D	E	F	G	J	K	M	N	O	Tap	Hole Dia.	Key
SC2RPS	08	0.500	6.00	2.562	1.125	2.00	3.50	1.500	0.375	1.00	5.500	4.00	1.375	0.375	1.45	0.63	10-24	0.22	3/32 sq x 5/8 lg
SC2RPS	10	0.625	7.00	2.750	1.125	2.50	4.00	1.625	0.375	1.00	6.312	4.00	1.375	0.375	1.45	0.63	1/4-20	0.28	3/32 sq x 5/8 lg
SC2RPS	12	0.750	8.00	3.438	1.500	2.75	4.50	1.750	0.500	1.25	7.125	6.00	1.500	0.375	1.45	0.63	1/4-20	0.28	3/32 sq x 5/8 lg
SC2RPS	16	1.000	9.00	3.938	1.750	3.25	5.50	2.125	0.500	1.25	8.312	6.00	2.125	0.625	1.76	1.00	1/4-20	0.28	3/16 sq x 1" lg
SC2RPS	20	1.250	11.00	5.125	2.125	4.00	6.50	2.500	0.750	1.50	10.000	6.00	2.375	0.625	1.76	1.00	5/16-18	0.34	3/16 sq x 1" lg
SC2RPS	24	1.500	13.00	5.750	2.500	4.75	8.00	3.000	0.750	1.50	12.000	8.00	2.875	0.875	2.31	1.50	5/16-18	0.34	1/4 sq x 1.62 lg
SC2RPS	32	2.000	18.00	7.375	3.250	6.00	10.00	3.750	1.000	1.75	15.875	8.00	3.875	0.875	2.31	1.50	3/8-16	0.41	1/4 sq x 1.62 lg

Dimensions in inches

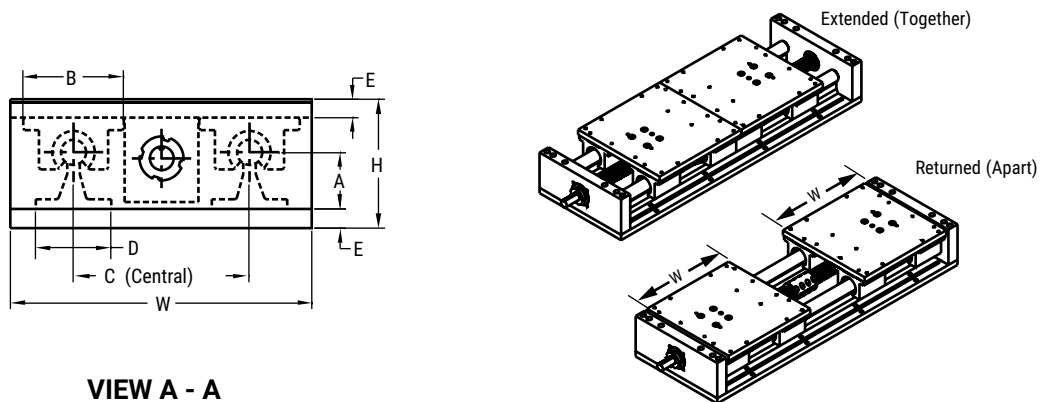
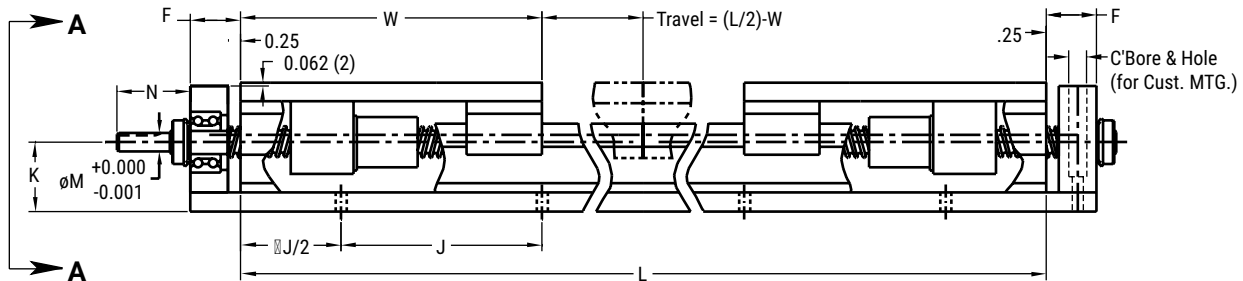
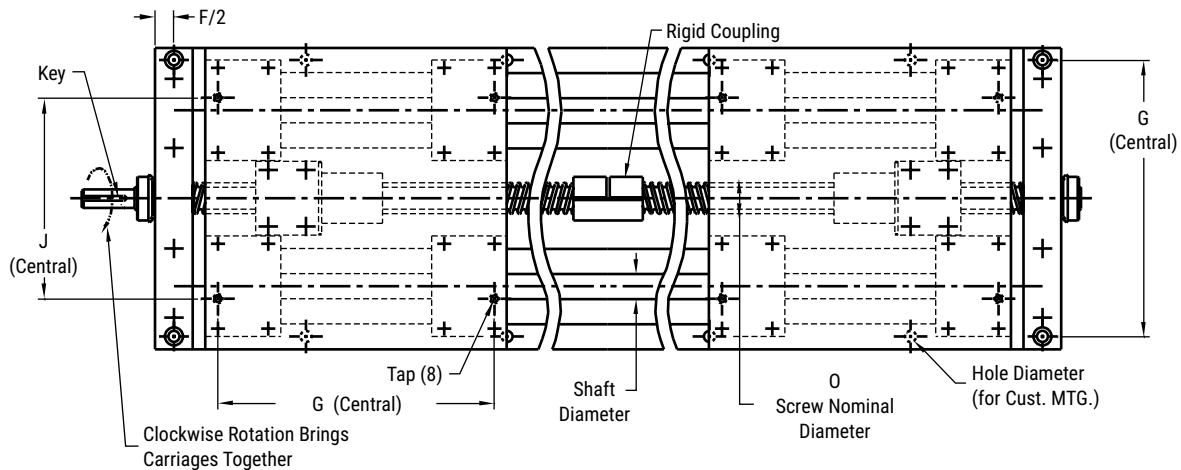

VIEW A - A

\*Hole distance to each end is equal unless specified at time of order.

# Simplicity® Linear Slides Handcrank & Wheel

INCH

ISO METRIC

JIS METRIC

## Slide Assembly with Hand Crank & Ball Screw Rotational Lock 2HCR & 2HWL

### Ordering Example:

To order a slide with a 0.625" diameter alloy steel linear shaft, 28" rail length, 0.200" right hand select ball screw and a hand wheel – specify part number, 2HWL-1000-028.000-AA7R.

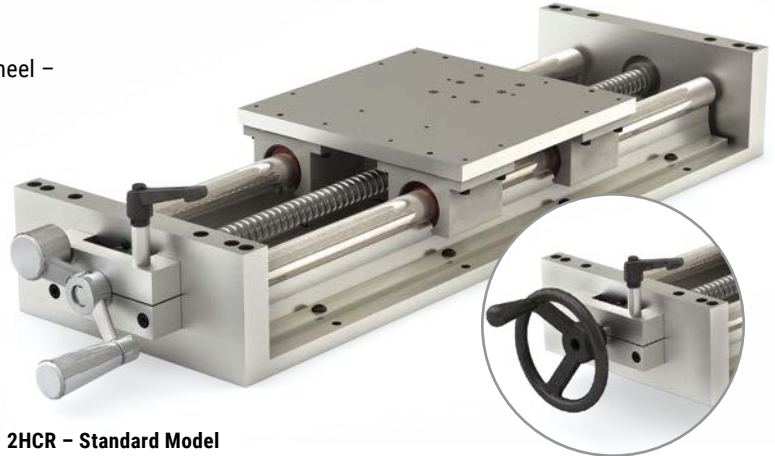

### Part Number

Series	Size	L	Lead
2HXX X XXX - 08 XX - XXX.XXX - YYYY			
2HXX X XXX - 10 XX - XXX.XXX - YYYY			
2HXX X XXX - 12 XX - XXX.XXX - YYYY			
2HXX X XXX - 16 XX - XXX.XXX - YYYY			
2HXX X XXX - 20 XX - XXX.XXX - YYYY			
2HXX X XXX - 24 XX - XXX.XXX - YYYY			
2HXX X XXX - 32 XX - XXX.XXX - YYYY			

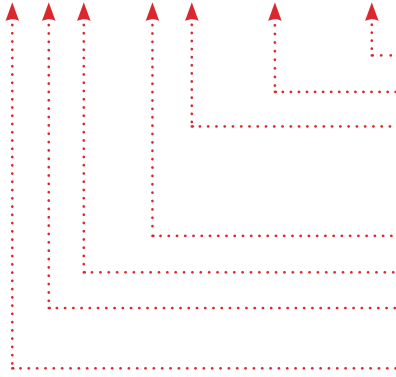

Substitute standard or select lead code from table for "YYYY"

Enter rail length in inches XXX.XXX (EX: 28" = 028.000)

Shafting material: **00** = Alloy Steel (Standard) **CC** = Ceramic Coated  
**S3** = 316 Stainless Steel **SS** = 440 Stainless Steel  
**S4** = 420 Stainless Steel  
 Note: Ball bearings not suitable with ceramic coated shafting.

Shaft diameter dimension in 1/16" increments

Internal Lubrication: **No Entry** = None (Standard) **JKM** = Thru hole and internal felt wick

Bearing Type: **No Entry** = Simplicity FrelonGOLD® **E** = Simplicity Frelon® J  
**B** = Ball Bearing

Handle Type: **CR** = Standard Model **WL** = Deluxe Model  
 (See table below)

### 2HCR – Standard Model

Cast aluminum counter balanced hand crank.  
 24 and 32 (only) spoked cast iron hand wheel with rigid, revolving crank handle.

### 2HWL – Deluxe Model

Aluminum hand wheel with fold-away composite handle.

### Standard Lead Table

Accurate to less than 0.007" per foot accumulative

Size	Available Lead Codes					
08	AAXR	AAXL				
10	AAXR	AAXL				
12	AAXR	AAXL				
16			ABXR	ABXL	ACXR	ADXR
20			ABXR	ABXL	ACXR	ADXR
24			ABXR	ABXL	ACXR	ADXL
32			ABXR	ABXL	ACXR	ADXL

AAXR = 0.20 Right Hand  
 AAXL = 0.20 Left Hand  
 ABXR = 0.25 Right Hand  
 ABXL = 0.25 Left Hand  
 ACXR = 0.50 Right Hand  
 ADXR = 1.00 Right Hand  
 ADXL = 1.00 Left Hand

Note: Additional leads available upon request.

### Select Lead Table

Accurate to less than 0.003" per foot accumulative

Size	Available Lead Codes					
08	AA7R	AA7L				
10	AA7R	AA7L				
12	AA7R	AA7L				
16			AB7R	AB7L	AC7R	AD7R
20			AB7R	AB7L	AC7R	AD7R
24			AB7R	AB7L	AC7R	AD7L
32			AB7R	AB7L	AC7R	AD7L

AA7R = 0.20 Right Hand  
 AA7L = 0.20 Left Hand  
 AB7R = 0.25 Right Hand  
 AB7L = 0.25 Left Hand  
 AC7R = 0.50 Right Hand  
 AD7R = 1.00 Right Hand  
 AD7L = 1.00 Left Hand

Note: Additional leads available upon request.

### Standard Length Table

Size	Available Rail Lengths – L* (in inches)																													
08	008	012	016		020	024	028		032	036	040		044	048	052		056	060	064		068	072	076		080	084	088		092	096
10	008	012	016		020	024	028		032	036	040		044	048	052		056	060	064		068	072	076		080	084	088		092	096
12		012		018		024		030		036		042		048		054		060		066		072		078		084		090	096	
16		012		018		024		030		036		042		048		054		060		066		072		078		084		090	096	
20		012		018		024		030		036		042		048		054		060		066		072		078		084		090	096	
24			016			024			032		040			048			056		064			072			080		088		096	
32						024			032		040			048			056		064			072			080		088		096	

\*Contact factory for longer or non-standard lengths.

# Simplicity® Linear Slides Handcrank & Wheel

## DIMENSIONAL INFORMATION

Series	Size	Linear Shaft Dia.	W	H	A	B	C	D	E	F	G	J	K	O	P	Q	R	S	T	U	V	X	Y	Z	Tap	Hole Dia.
2HXX	08	0.500	6	2.562	1.125	2.00	3.5	1.500	0.375	0.75	5.500	4.00	1.375	0.631	2.56	3.85	3.00	0.875	1.312	4.00	4	4	2.655	4.855	10-24	0.22
2HXX	10	0.625	7	2.750	1.125	2.50	4.0	1.625	0.375	0.75	6.312	4.00	1.375	0.631	2.56	3.85	3.00	0.875	1.312	4.00	4	4	2.655	4.855	1/4-20	0.28
2HXX	12	0.750	8	3.438	1.500	2.75	4.5	1.750	0.500	1.00	7.125	6.00	1.500	0.631	2.56	3.85	3.00	0.875	1.312	4.00	4	4	2.655	4.855	1/4-20	0.28
2HXX	16	1.000	9	3.938	1.750	3.25	5.5	2.125	0.500	1.00	8.312	6.00	2.125	1.000	2.56	3.69	4.25	1.125	2.000	4.25	5	6	3.185	5.745	1/4-20	0.28
2HXX	20	1.250	11	5.125	2.125	4.00	6.5	2.500	0.750	1.25	10.000	6.00	2.375	1.000	2.56	3.69	4.25	1.125	2.000	4.25	5	6	3.185	5.745	5/16-18	0.34
2HXX	24	1.500	13	5.750	2.500	4.75	8.0	3.000	0.750	1.25	12.000	8.00	2.875	1.500	3.15	5.81	6.50	1.500	3.000	6.90	8	8	4.310	7.460	5/16-18	0.34
2HXX	32	2.000	18	7.375	3.250	6.00	10.0	3.750	1.000	1.50	15.875	8.00	3.875	1.500	3.15	5.81	6.50	1.500	3.000	6.90	8	8	4.310	7.460	3/8-16	0.41

Dimensions in inches

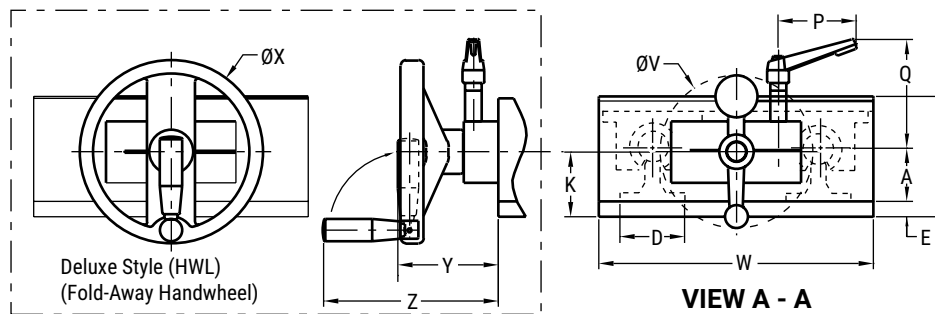
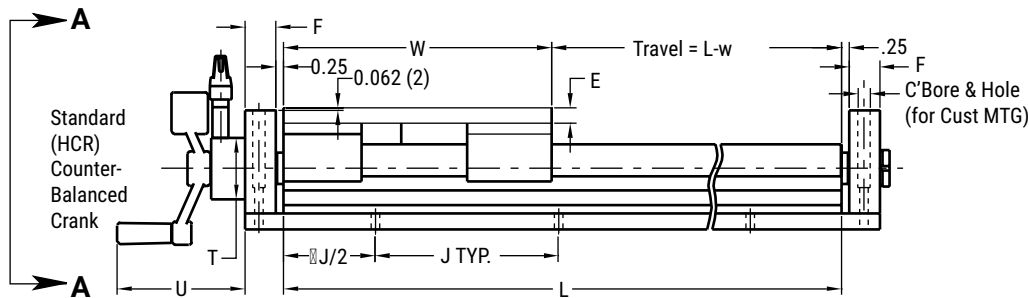
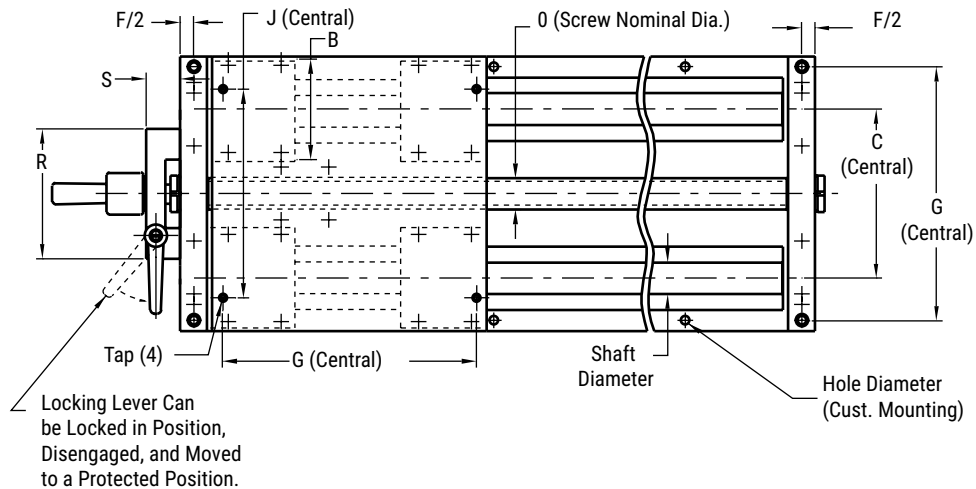

\*Hole distance to each end is equal unless specified at time of order.

# Simplicity® Linear Slides Nema Drive Kit

INCH

ISO METRIC

JIS METRIC

## Slide Assembly & Nema Drive Kit 2N42, 56, 143

### Ordering Example:

To order a slide with a 1" diameter alloy steel linear shaft, 28" rail length, 0.250" right hand select ball screw, and a NEMA 56 motor with a 0.625" shaft – specify part number, 2N56-1600-028.000-AB7R.

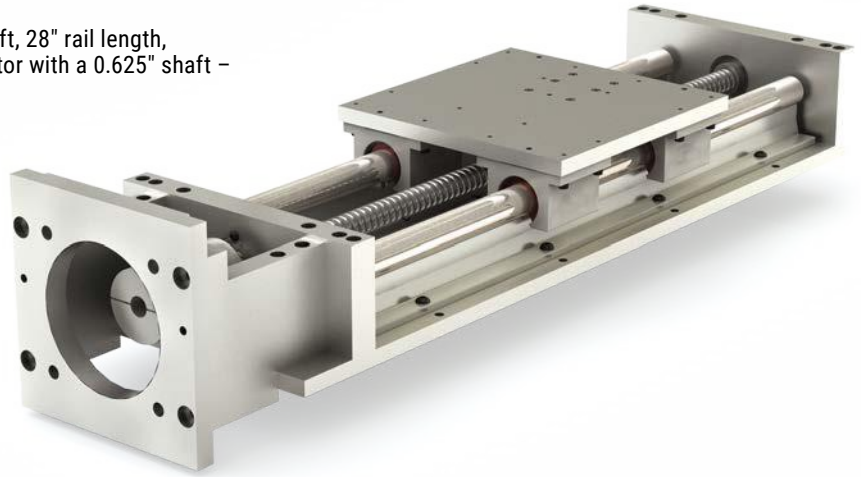

### Part Number

Series	Size	L	Lead
2NXX X XXX - 16 XX - XXX.XXX - YYYY			
2NXX X XXX - 20 XX - XXX.XXX - YYYY			
2NXX X XXX - 24 XX - XXX.XXX - YYYY			
2NXX X XXX - 32 XX - XXX.XXX - YYYY			

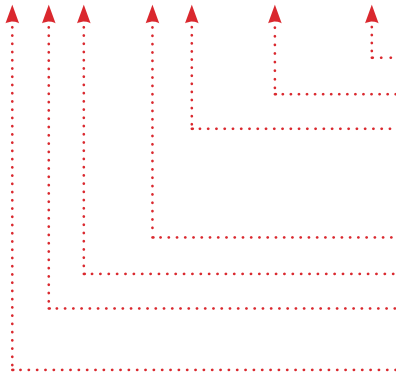

Substitute standard or select lead code from table for "YYYY"

Enter rail length in inches XXX.XXX (EX: 28" = 028.000)

Shafting material: **00** = Alloy Steel (Standard) **CC** = Ceramic Coated  
**S3** = 316 Stainless Steel **SS** = 440 Stainless Steel  
**S4** = 420 Stainless Steel  
**Note:** Ball bearings not suitable with ceramic coated shafting.

Shaft diameter dimension in 1/16" increments

Internal Lubrication: **No Entry** = None (Standard) **JKM** = Thru hole and internal felt wick

Bearing Type: **No Entry** = Simplicity FrelonGOLD® **E** = Simplicity Frelon® J  
**B** = Ball Bearing

Motor Mounting Dimensions: See table below

### Standard Lead Table

Accurate to less than 0.007" per foot accumulative

Size	Available Lead Codes				
16	ABXR	ABXL	ACXR	ADXR	
20	ABXR	ABXL	ACXR	ADXR	
24	ABXR	ABXL	ACXR	ADXR	ADXL
32	ABXR	ABXL	ACXR	ADXR	ADXL

ABXR = 0.25 Right Hand  
 ABXL = 0.25 Left Hand  
 ACXR = 0.50 Right Hand  
 ADXR = 1.00 Right Hand  
 ADXL = 1.00 Left Hand

**Note:** Additional leads available upon request.

### Select Lead Table

Accurate to less than 0.003" per foot accumulative

Size	Available Lead Codes					
16	AB7R	AB7L	AC7R	AD7R		
20	AB7R	AB7L	AC7R	AD7R		
24	AB7R	AB7L	AC7R	AD7R	AD7L	
32	AB7R	AB7L	AC7R	AD7R	AD7L	

AB7R = 0.25 Right Hand  
 AB7L = 0.25 Left Hand  
 AC7R = 0.50 Right Hand  
 AD7R = 1.00 Right Hand  
 AD7L = 1.00 Left Hand

**Note:** Additional leads available upon request.

### Motor Mounting Dimensions

Coupling MAX\* Torque Dynamic Capacity = 200 in.-lb.

Size	Drive	R	S	V	X	Y	Z
42A	NEMA 42	3.000	0.375	5.000	0.28	3.750	2.652
42B	NEMA 42	2.188	0.625	5.000	5/16-18	4.950	3.500
56	NEMA 56	4.500	0.625	7.000	0.41	5.875	4.154
143	NEMA 143/145	4.500	0.875	7.000	0.41	5.875	4.154

**Note:** Contact factory for international drives and low profile slide assembly availability.

\*Due to ball screw and nut life/torque capacities for 16 and 20 size slides, do not exceed 100 in.-lb. of input torque without consulting factory.

### Standard Length Table

Size	Available Rail Lengths – L** (in inches)														
16	012	018	024	030	036	042	048	054	060	066	072	078	084	090	096
20	012	018	024	030	036	042	048	054	060	066	072	078	084	090	096
24		016	024	032	040	048	056	064	072	080	088	096			
32			024	032	040	048	056	064	072	080	088	096			

\*\*Contact factory for longer or non-standard lengths.

# Simplicity® Linear Slides Nema Drive Kit

## DIMENSIONAL INFORMATION

Series	Size	Linear Shaft Dia.	W	H	A	B	C	D	E	F	G	J	K	M	N	O	Q	Tap	Hole Dia.
2NXX	16	1.00	9.00	3.938	1.750	3.25	5.50	2.12	0.50	1.00	8.312	6.00	2.125	0.625	1.76	1.00	3.00	1/4-20	0.28
2NXX	20	1.25	11.00	5.125	2.125	4.00	6.50	2.50	0.75	1.25	10.000	6.00	2.375	0.625	1.76	1.00	3.00	5/16-18	0.34
2NXX	24	1.50	13.00	5.750	2.500	4.75	8.00	3.00	0.75	1.25	12.000	8.00	2.875	0.875	2.31	1.50	2.62	5/16-18	0.34
2NXX	32	2.00	18.00	7.375	3.250	6.00	10.00	3.75	1.00	1.75	15.875	8.00	3.875	0.875	2.31	1.50	2.62	3/8-16	0.41

Dimensions in inches

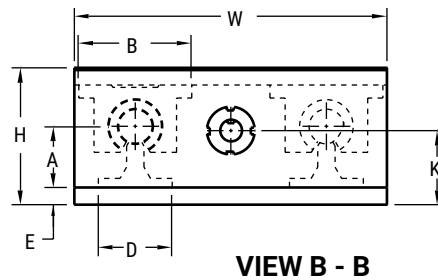
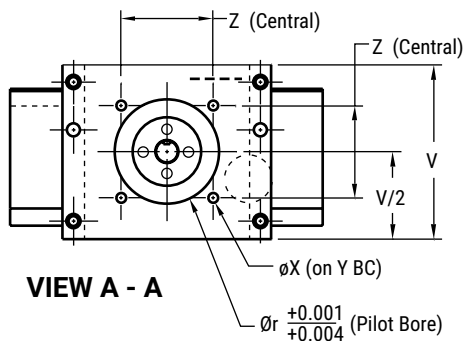
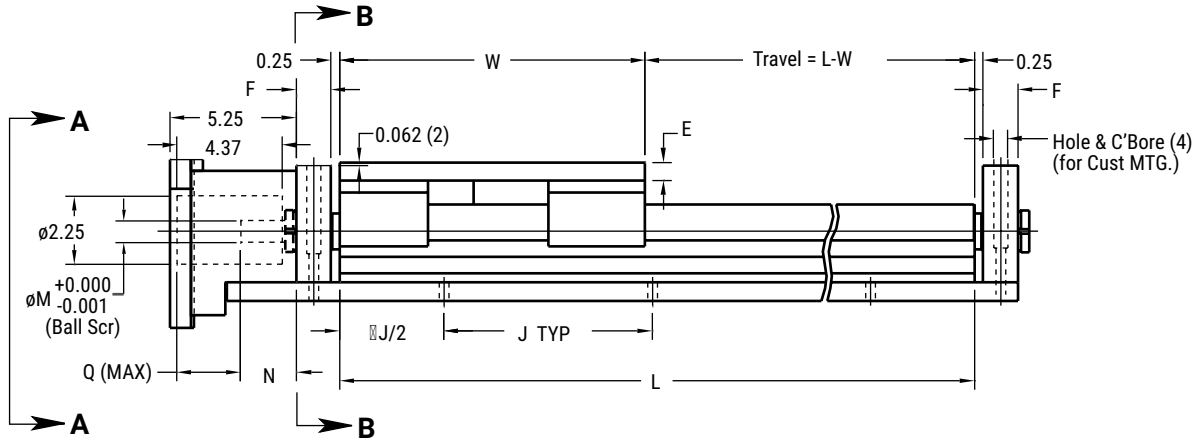
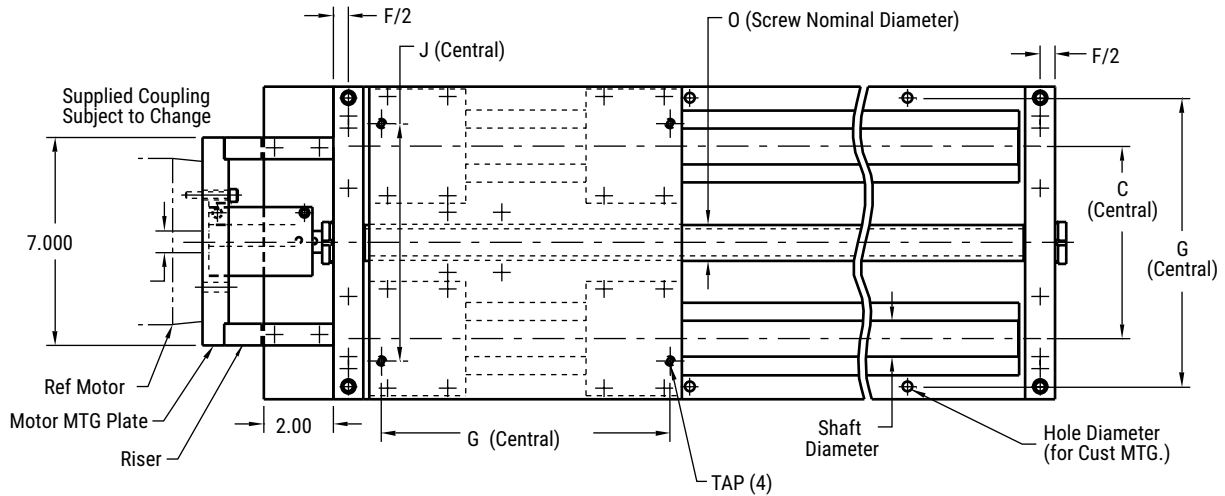

\*Hole distance to each end is equal unless specified at time of order.

# Simplicity® Linear Slides Nema Drive Kit

INCH

ISO METRIC

JIS METRIC

## Slide Assembly & NEMA Drive Kit 2N23 & 2N34

### Ordering Example:

To order a slide with a 0.625" diameter alloy steel linear shaft, 28" rail length, 0.200" right hand select ball screw, and a NEMA 23 motor with a 0.250" shaft – specify part number, 2N23A-1000-028.000-AA7R.



### Part Number

Series	Size	L	Lead
2NXX X XXX - 08 XX - XXX.XXX - YYYY			
2NXX X XXX - 10 XX - XXX.XXX - YYYY			
2NXX X XXX - 12 XX - XXX.XXX - YYYY			
2NXX X XXX - 16 XX - XXX.XXX - YYYY			
2NXX X XXX - 20 XX - XXX.XXX - YYYY			

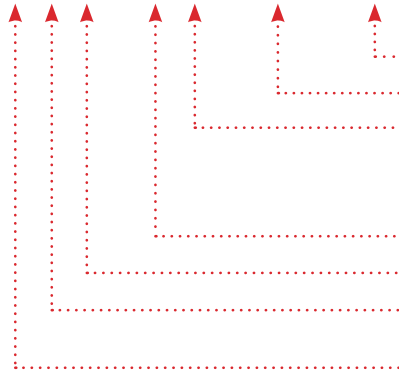

Substitute standard or select lead code from table for "YYYY"

Enter rail length in inches XXX.XXX (EX: 28" = 028.000)

Shafting material: **00** = Alloy Steel (Standard) **CC** = Ceramic Coated  
**S3** = 316 Stainless Steel **SS** = 440 Stainless Steel  
**S4** = 420 Stainless Steel  
 Note: Ball bearings not suitable with ceramic coated shafting.

Shaft diameter dimension in 1/16" increments

Internal Lubrication: **No Entry** = None (Standard) **JKM** = Thru hole and internal felt wick

Bearing Type: **No Entry** = Simplicity FrelonGOLD® **E** = Simplicity Frelon® J  
**B** = Ball Bearing

Motor Mounting Dimensions: See table below

### Standard Lead Table

Accurate to less than 0.007" per foot accumulative

Size	Available Lead Codes					
08	AAXR	AAXL				
10	AAXR	AAXL				
12	AAXR	AAXL				
16			ABXR	ABXL	ACXR	ADXR
20			ABXR	ABXL	ACXR	ADXR

AAXR = 0.20 Right Hand  
 AAXL = 0.20 Left Hand  
 ABXR = 0.25 Right Hand  
 ABXL = 0.25 Left Hand  
 ACXR = 0.50 Right Hand  
 ADXR = 1.00 Right Hand

Note: Additional leads available upon request.

### Select Lead Table

Accurate to less than 0.003" per foot accumulative

Size	Available Lead Codes					
08	AA7R	AA7L				
10	AA7R	AA7L				
12	AA7R	AA7L				
16			AB7R	AB7L	AC7R	AD7R
20			AB7R	AB7L	AC7R	AD7R

AA7R = 0.20 Right Hand  
 AA7L = 0.20 Left Hand  
 AB7R = 0.25 Right Hand  
 AB7L = 0.25 Left Hand  
 AC7R = 0.50 Right Hand  
 AD7R = 1.00 Right Hand

Note: Additional leads available upon request.

### Motor Mounting Dimensions

Coupling MAX\* Torque Dynamic Capacity = 50 in.-lb.

Size	Drive	R	S	V	X	Y	Z
23A	NEMA 23	1.502	0.250	2.500	10-32	2.625	1.856
23B	NEMA 23	1.502	0.375	2.500	10-32	2.625	1.856
34A	NEMA 34	2.875	0.375	3.500	10-32	3.875	2.740
34B	NEMA 34	2.875	0.500	3.500	10-32	3.875	2.740

Note: Contact factory for international drives and low profile slide assembly availability.

\*Due to ball screw and nut life/torque capacities for 08, 10, or 12 size slides, do not exceed 30 in.-lb. of input torque without consulting factory.

### Standard Length Table

Size	Available Rail Lengths - L** (in inches)																												
08	008	012	016		020	024	028		032	036	040		044	048	052		056	060	064	068	072	076		080	084	088		092	096
10	008	012	016		020	024	028		032	036	040		044	048	052		056	060	064	068	072	076		080	084	088		092	096
12		012		018		024		030		036		042		048		054		060		066		072		078		084		090	096
16		012		018		024		030		036		042		048		054		060		066		072		078		084		090	096
20		012		018		024		030		036		042		048		054		060		066		072		078		084		090	096

\*\*Contact factory for longer or non-standard lengths.

# Simplicity® Linear Slides Nema Drive Kit

## DIMENSIONAL INFORMATION

Series	Size	Linear Shaft Dia.	W	H	A	B	C	D	E	F	G	J	K	M	N	O	Q	Tap	Hole Dia.
2NXX	08	0.500	6.00	2.562	1.125	2.00	3.50	1.500	0.375	0.75	5.500	4.00	1.375	0.375	1.45	0.631	1.31	10-24	0.22
2NXX	10	0.625	7.00	2.750	1.125	2.50	4.00	1.625	0.375	0.75	6.312	4.00	1.375	0.375	1.45	0.631	1.31	1/4-20	0.28
2NXX	12	0.750	8.00	3.438	1.500	2.75	4.50	1.750	0.500	1.00	7.125	6.00	1.500	0.375	1.45	0.631	1.31	1/4-20	0.28
2NXX	16	1.000	9.00	3.938	1.750	3.25	5.50	2.125	0.500	1.00	8.312	6.00	2.125	0.625	1.76	1.000	1.19	1/4-20	0.28
2NXX	20	1.250	11.00	5.125	2.125	4.00	6.50	2.500	0.750	1.25	10.000	6.00	2.375	0.625	1.76	1.000	1.19	5/16-18	0.34

Dimensions in inches

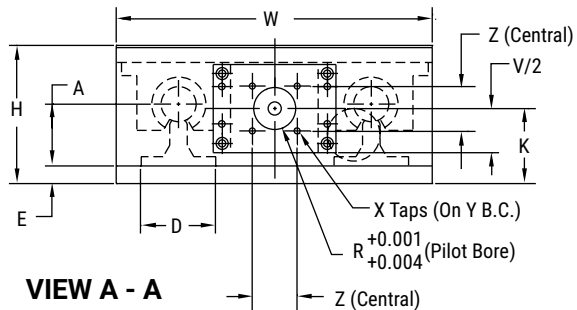
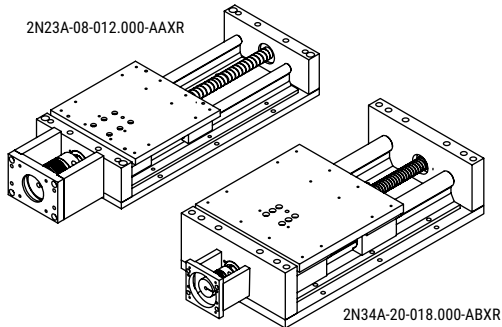
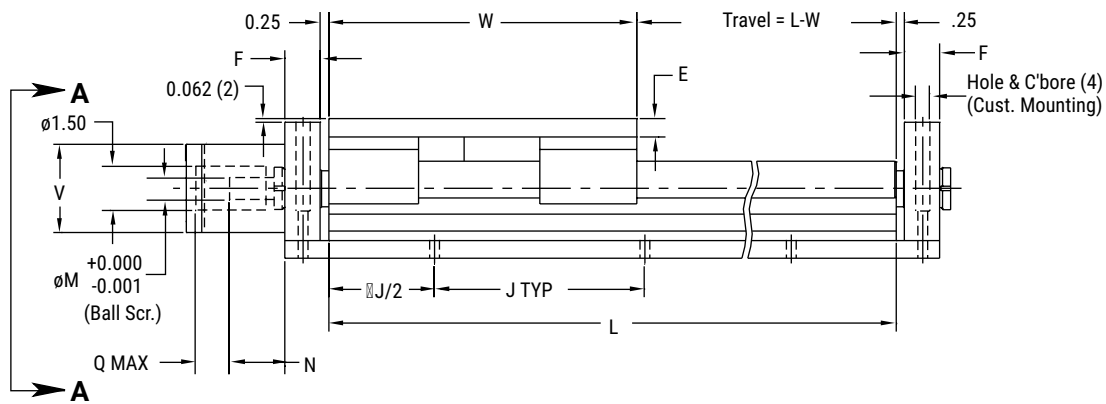
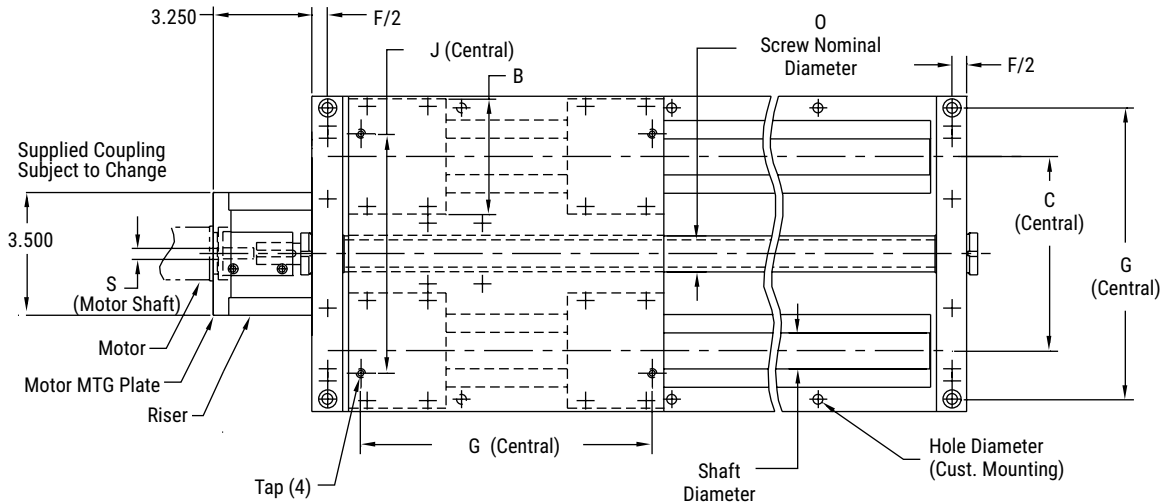

\*Hole distance to each end is equal unless specified at time of order.

INCH

ISO METRIC

JIS METRIC

# Simplicity<sup>®</sup> Linear Slides

INCH

ISO METRIC

JIS METRIC

## Slide Selection Information

1. Determine the size and stroke of slide
2. Is a lube system required?
3. Please furnish the following to the factory:
  - a. Model designation
  - b. Lube system requirements
  - c. Mounting orientation, saddle position if mounted at an angle
  - d. Load to be carried and approximate center of gravity from saddle center
  - e. Location and magnitude of any force which resists the motion of the slide
  - f. Acceleration rate and maximum velocity of the saddle
  - g. Deceleration rate
  - h. Service life requirements
  - i. Type of environment the slide will operate in

## Model Number

Series Code    Size Code    Length Code    Ball Screw Lead Code

## Mounting Orientation

Please indicate the parameters of your application in the boxes below:

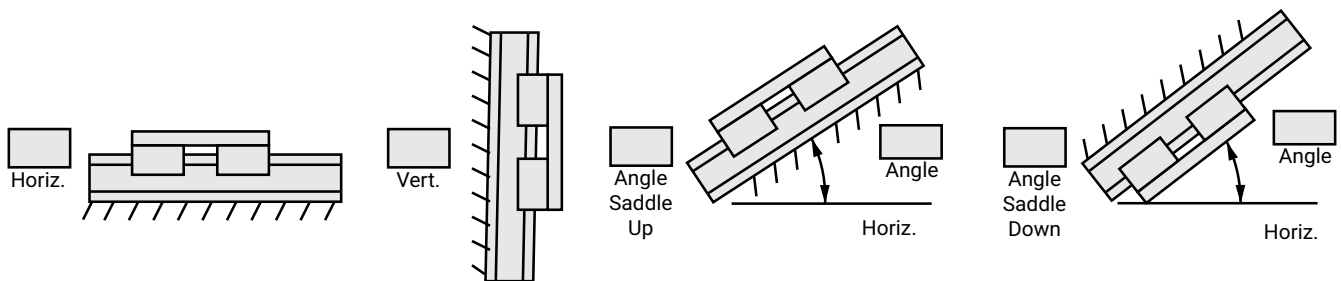

Cycle Rate:	<input type="text"/>	Per Hour:	<input type="text"/>	Per Minute:	<input type="text"/>
MAX Saddle Velocity:	<input type="text"/>	Inch/Second:	<input type="text"/>		
Acceleration Rate:	<input type="text"/>	Inches/Second <sup>2</sup> :	<input type="text"/>		
Deceleration Rate:	<input type="text"/>	Inches/Second <sup>2</sup> :	<input type="text"/>		
Load:	<input type="text"/>	lbs.	<input type="text"/>		

## Location of Center of Gravity from Saddle Center

Please indicate the parameters of your application in the boxes below:

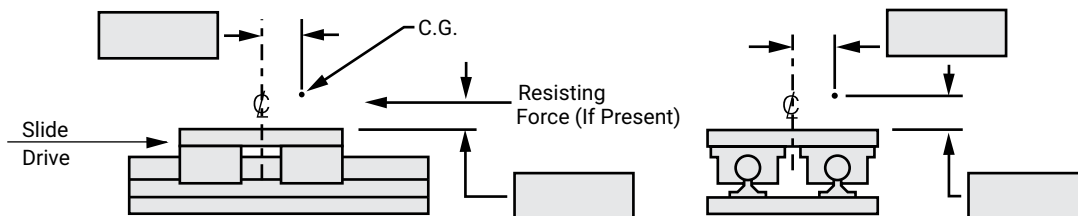

**Note:** Example of "Resisting Force" would be tool thrust for a drill head mounted on slide.

Resisting Force:	<input type="text"/>	lbs.
Life Requirement:	<input type="text"/>	Strokes: <input type="text"/> Hours

# Simplicity® Linear Slides Load Capacities

The safe loading recommendations shown apply to plain bearing, non-lubricated slide applications. All slides are to be fully supported and rigidly mounted. **Load capacities shown reflect the use of Simplicity linear plain bearings.** Contact PBC Linear for load capacities for linear slides with ball bearings.

## Standard Mounting

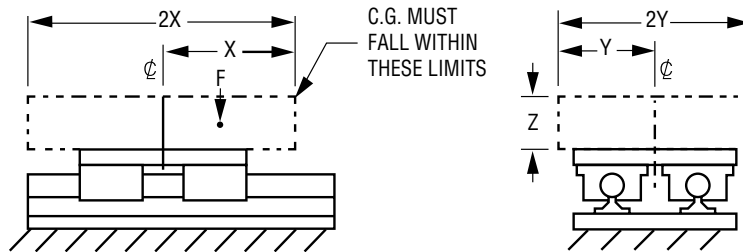

### RECOMMENDED SAFE LOADING

Size	F MAX lb.	F MAX N	X in.	Y in.	Z in.
08	1450	6450	4.00	2.37	3.00
10	2200	9786	4.75	2.76	3.50
12	2850	12677	5.00	2.85	4.00
16	5275	23464	5.50	3.37	4.50
20	7750	34473	6.75	4.05	5.50
24	10600	47151	7.86	4.90	6.50
32	18750	83400	10.75	6.00	9.00

**Note:** Load ratings apply to Simplicity plain bearings only.

## Side Mounting

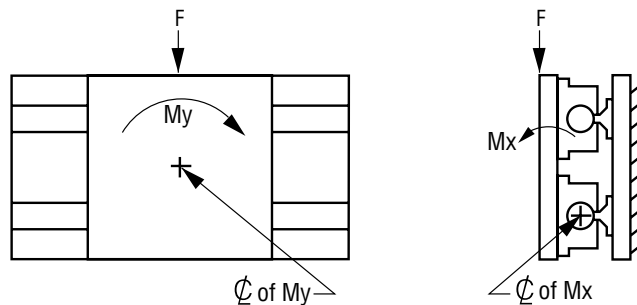

### RECOMMENDED SAFE LOADING

Size	F MAX lb.	My in.-lb.	Mx in.-lb.	F Max N	My nm	Mx nm
08	540	910	1500	2402	103	169
10	760	1680	2750	3381	190	311
12	840	1710	2875	3737	193	325
16	1050	3300	4430	4671	373	501
20	1750	6175	8750	7784	698	989
24	2100	9600	12600	9341	1085	1424
32	3300	19000	28050	14679	2147	3169

**Note:** Load ratings apply to Simplicity plain bearings only.

INCH

ISO METRIC

JIS METRIC

# Simplicity® Linear Slides Load Capacities

## Inverted Mounting

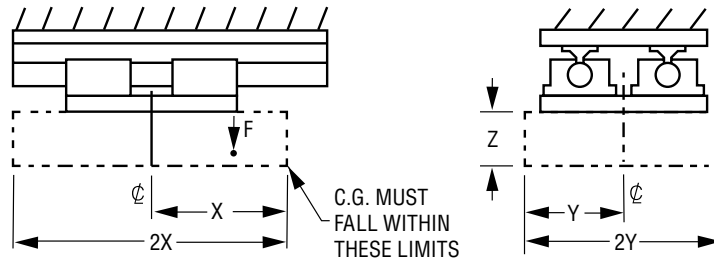

### RECOMMENDED SAFE LOADING

Size	F MAX lb.	F MAX N	X in.	Y in.	Z in.
08	195	867	4.85	2.91	3.00
10	285	1268	5.69	3.33	3.50
12	315	1401	6.52	3.75	4.00
16	450	2002	7.31	4.58	4.50
20	712	3167	8.84	5.42	5.50
24	900	4003	10.50	6.67	6.50
32	1425	6339	14.67	8.33	9.00

**Note:** Load ratings apply to Simplicity plain bearings only.

## Vertical Mounting

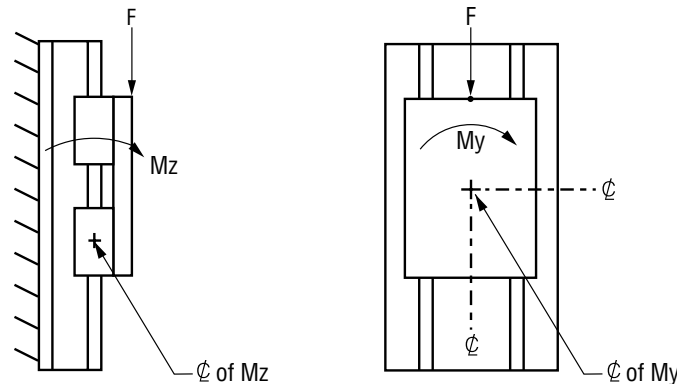

### RECOMMENDED SAFE LOADING

Size	F MAX <sup>1,2</sup> lb.	My in.-lb.	Mz in.-lb.	F MAX N	My nm	Mz nm
08	260	1445	1500	1157	163	169
10	300	2750	2750	1334	311	311
12	300	2875	2875	1334	325	325
16	600	5000	4430	2669	565	501
20	675	9500	8750	3003	1073	989
24	710	14400	12600	3158	1627	1424
32	900	32300	28050	4003	3649	3169

**Note:** Load ratings apply to Simplicity plain bearings only. <sup>1</sup> Applies only when using 2RPS and 2LRPS slides. <sup>2</sup> If "F" is exceeded consult factory. For RPS, FMAX is dependent upon customer's method of moving the slide.

# Simplicity® Linear Slides Column Load Chart

## Compression (Column) Load

Compression-column load is a load that tends to buckle or compress the screw shaft.

### How To Use Chart:

1. Determine maximum compression load (lb.)
2. Determine slide length. ("L" dimension)
3. Determine end fixity and slide designation (2RPS and 2LRPS)
4. Find the point at which load and length intersect
5. Select a slide above or to the right of the intersecting point

**Note:** Applies primarily to vertical applications.

### Column Load Formulas:

$$P_c = C_c \cdot 14.03 \times 10^6 \cdot \left( \frac{D^4}{L^2} \right)$$

$P_c$  = Critical column load (lb.)

$D$  = Root diameter of screw (in.) (See chart)

$L$  = Slide length (in.)

$C_c$  = End fixity factor

$C_c$  = .25 for 1RPS

$C_c$  = 2.0 for 2RPS and 2LRPS

**Note:** Chart figures at 80% of actual load. Do not exceed these figures.

Curve #	Slide Series		Lead	D (in.)
1	1 & 2RPS-08	2LRPS-08	AAxx	.500
	1 & 2RPS-10	2LRPS-10		
	1 & 2RPS-12	2LRPS-12		
2	1 & 2RPS-16	2LRPS-16	ABxx	.840
	1 & 2RPS-20	2LRPS-20		
	1 & 2RPS-16	2LRPS-16	ADxx	
	1 & 2RPS-20	2LRPS-20		
	1 & 2RPS-16	2LRPS-16	ACxx	
	1 & 2RPS-20	2LRPS-20		
3	1 & 2RPS-24	2LRPS-24	ADxx	1.140
	1 & 2RPS-32	2LRPS-32		
4	1 & 2RPS-24	2LRPS-24	ACxx	1.260
	1 & 2RPS-32	2LRPS-32		
5	1 & 2RPS-24	2LRPS-24	ABxx	1.375
	1 & 2RPS-32	2LRPS-32		

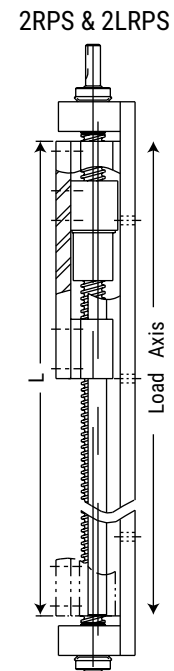
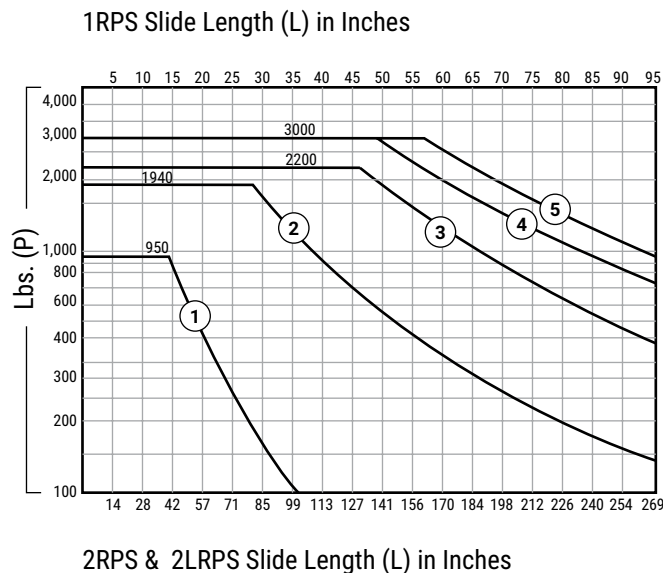
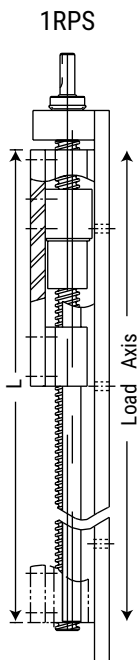

# Simplicity® Linear Slides Critical Speed Chart

INCH

ISO METRIC

JIS METRIC

## Critical Speed

The maximum speed at which a ball screw or ball nut can rotate without producing destructive resonant vibrations. The critical speed is a function of the ball screw diameter, the unsupported length of the screw, rigidity of the bearing supports, and RPM.

### How To Use Chart:

1. Determine end fixity. How many ends are fixed? (Slide designation, 2RPS and 2LRPS)
2. Determine slide length. ("L" dimension)
3. Find the length – fixity vertical line, read up to find the intersecting, at the required travel rate
4. Select a slide above or to the right of the intersection point
5. Higher speeds and/or longer lengths are available as cost effective specials, having a larger ball screw and bearings

## Critical Speed Formulas:

$$N = C_s \cdot 7.93 \times 10^4 \cdot \left(\frac{DH}{L^2}\right)$$

**N** = Critical speed (MAX) (expressed in in./sec.)

**D** = Root diameter of screw (See chart)

**H** = Lead of screw (in.) (See chart)

**L** = Slide length (in.)

**C<sub>s</sub>** = End fixity factor

**C<sub>s</sub>** = 0.36 for 1RPS

**C<sub>s</sub>** = 1.47 for 2RPS and 2LRPS

**Note:** Chart figures at 80% of actual load. Do not exceed these figures.

Curve #	Slide Series		Lead	D (in.)	H (in.)
1	1 & 2RPS-08	2LRPS-08	AAxx	.500	.200
	1 & 2RPS-10	2LRPS-10			
	1 & 2RPS-12	2LRPS-12			
2	1 & 2RPS-16	2LRPS-16	ABxx	.840	.250
	1 & 2RPS-20	2LRPS-20			
3	1 & 2RPS-24	2LRPS-24	ABxx	1.375	.250
	1 & 2RPS-32	2LRPS-32			
4	1 & 2RPS-16	2LRPS-16	ACxx	.870	.500
	1 & 2RPS-20	2LRPS-20			
5	1 & 2RPS-24	2LRPS-24	ACxx	1.260	.500
	1 & 2RPS-32	2LRPS-32			
6	1 & 2RPS-16	2LRPS-16	ADxx	.840	1.000
	1 & 2RPS-20	2LRPS-20			
7	1 & 2RPS-24	2LRPS-24	ADxx	1.140	1.000
	1 & 2RPS-32	2LRPS-32			

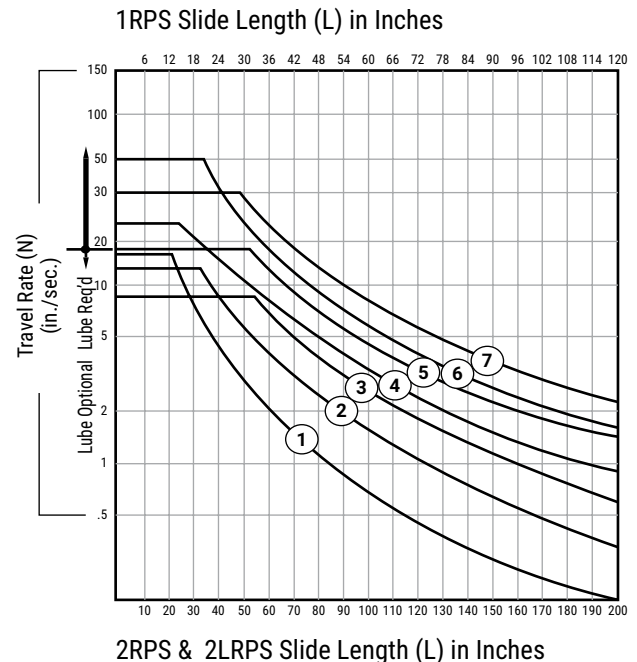
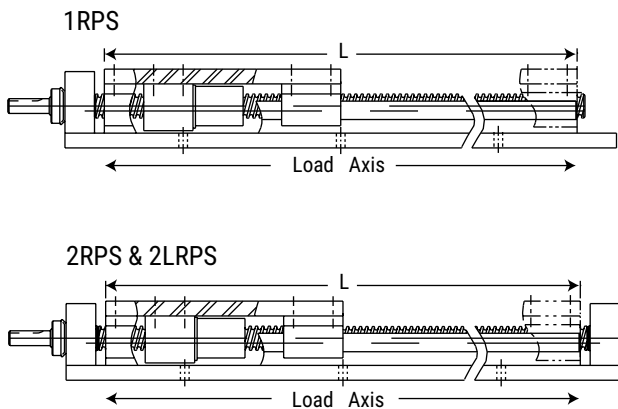

# Round Shaft Technology Technical

## TABLE OF CONTENTS

### Simplicity® Linear Plain Bearings

Ratings for Plain Bearings . . . . .	138
Types & Effects of Lubrication . . . . .	139
Load Capacity . . . . .	140
Wear Rate . . . . .	141
Coefficient of Friction . . . . .	142
Cantilevered Loads . . . . .	143
Shaft Deflection . . . . .	145
Installation . . . . .	147
Chemical Reaction Chart . . . . .	151

### Linear Ball Bearings

Load Rating . . . . .	152
Life expectancy & Calculations . . . . .	153
Clearance & Mounting . . . . .	155

### Roller Pillow Block Bearings

Load & Sizing . . . . .	157
Adjustments & Curves . . . . .	158
Cross Reference Guide. . . . .	159



Email an Application Engineer



# Ratings Simplicity® Plain Bearings

## Classes of Plain Bearings

Simplicity bearings are in a class of bearings known as Plain bearings, which means that they have no rolling elements. There are three classes of Plain bearings:

- Class I** – Require an outside source of lubrication (oil, grease, etc.).
- Class II** – Lubrication is impregnated within the walls of the bearing. (Bronze, powder metal, etc.) Typically, these bearings require an added lubricant also.
- Class III** – Self-lubricating bearings, which do not require added lubricants.

Simplicity bearings are Class III Plain bearings and are self-lubricating.

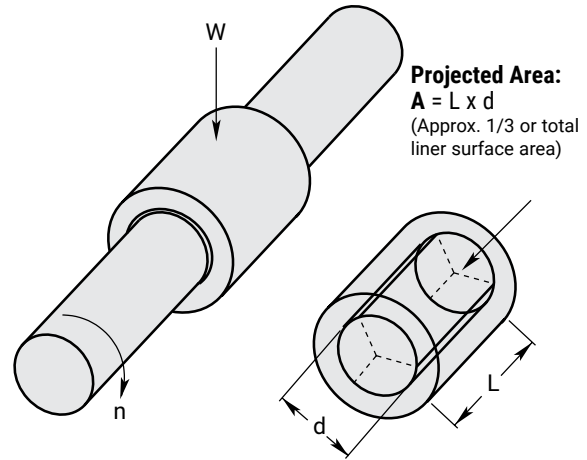

**Projected Area:**  
 $A = L \times d$   
 (Approx. 1/3 of total liner surface area)

- W** = MAX load
- L** = bearing length
- d** = shaft diameter
- A** = projected contact area
- n** = rotational speed (rpm)

## Rating a Plain Bearing

Plain bearing performance capacity is rated by PV.

- P** = Pressure or load in pounds per square inch (psi) or kilograms per square centimeter (kg/cm<sup>2</sup>).
- V** = Velocity or surface speed in feet per minute (fpm or sfm) or meters per minute (m/min.).
- PV** = Pressure velocity value (Pressure x Velocity).

## Formulas for Ratings

Pressure is over the projected area of load:

$$A = L \cdot d$$

$$P = \frac{W}{A} \text{ psi (or kg/cm}^2\text{)}$$

### Velocity:

Linear = total distance traveled in one minute

### Rotational Velocity:

$$V = \frac{\pi \cdot d \cdot n}{12} \text{ fpm (or m/min.)}$$

### Pressure velocity value (PV):

$$PV = P \cdot V \text{ psi} \cdot \text{fpm (or kg/cm}^2 \cdot \text{m/min.)}$$

## Simplicity Maximum Parameters

Maximum Parameters	P	V Running Dry	PV
Frelon® J	1500 psi or 105.45 kgf/cm <sup>2</sup>	140 sfm or 42.67 m/min.	10,000 psi x ft./min. or 215 kgf/cm <sup>2</sup> x m/min.
FrelonGOLD®	3000 psi or 210.9 kgf/cm <sup>2</sup>	300 sfm or 91.44 m/min.	20,000 psi x ft./min. or 430 kgf/cm <sup>2</sup> x m/min.

**Note:** All three parameters must be met by an application for the bearing to perform properly.

## PV equivalents

	Inch	Technical Metric	Int'l Metric (SI)
Load	1 psi	.0703 kgf/cm <sup>2</sup>	.0069 N/mm <sup>2</sup>
Velocity	1 ft./min.	.3048 m/min.	.00508 m/sec.
PV	1 PV	.0214 PV	.000036 PV
FrelonGOLD MAX PV	20,000	430	.72
Frelon J MAX PV	10,000	215	.36

# Types & Effects of Lubrication Simplicity® Plain Bearings

## Types and Effects of Lubrication

Lubrication is any outside technique used for reducing the friction, wear, or both of a bearing. **Proper lubrication of Simplicity bearings is critical.** Evaluate lubrication needs on an application-by-application basis to determine whether or not it should be used at all, what type is needed, and how it is applied. Below are some criteria on which to base the lubricant decision:

Do not use WD40™, PTFE sprays, or other oils, greases, or sprays that contain fluorocarbons or silicone. In testing, these lubricants have proven to cause long-term stick-slip problems with the Frelon lined bearings. They tend to become a gummy substance that ultimately increases friction.

WD40™ is a registered trademark of the WD40 Corporation.

### Recommended Lubricants:

- Waylube oils
- Lightweight oils
- 3-in-1 type oils
- Lightweight petroleum based greases

## Using Oils with Simplicity

### DO NOT USE ANY TYPE OF MOTOR OIL OR OILS WITH ADDITIVES!

These types of oils work well short term, but quickly become ineffective, and will cause stick-slip reactions in the bearing. As a rule of thumb, the less additives in the oil, the better the performance. Recommended oils are Mobil Vactra #2 (a way lube oil) and any standard 3-in-1 oil. The 3-in-1 oils are tremendous cleaning oils and are the best in preparing for a proper transfer of PTFE to the shafting.

## Grease Products

**DO NOT USE A MOLY FILLED OR OTHER TYPE FILLED GREASES!** They become like a lapping compound on the ID of the bearing and increase wear dramatically.

## Proper Use of Greases

Proper use of grease is critical for trouble-free operation.

Be sure the felt wick is removed from a "FL-xx-JKM" bearing because grease inserted through the zerk will cause the wick to act like a brake.

### Do not fill all of the running clearance with grease!

The temptation is to treat it like a rolling element bearing and fill it until it weeps from the end. This will cause greater friction and binding.

The rule of thumb for the bearing liner that "thin is better" applies to the use of grease also.

If grease is used and does not work in the application, it is possible to salvage the bearing with minimal work and to continue to operate. Follow the steps below:

1. If possible, remove the bearing from the housing, wipe the grease from the liner, use a 3-in-1 type oil to clean the excess remaining grease, and reinstall.
2. If it is not possible to remove the bearing, wipe as much grease as possible away from the ends of the bearing, then start to fill with a 3-in-1 type oil for cleaning the liner. To speed the cleaning process, apply forced air to the bearing through the zerk hole and continue using oil lubrication.

## Effects of Lubrication

Lubrication can greatly increase the performance of a bearing when applied properly as noted earlier. Actual performance results for specific applications are difficult to predict due to the number of elements involved (temperature change with lube, useable life, or aging of lubricant, etc.). Specific application testing is recommended to establish specific performance parameters.

# Load Capacity Simplicity® Plain Bearings

## Load Capacity (Pressure)

Depending upon the material used, a plain bearing's load capacity can greatly exceed a rolling element bearing. There are three basic reasons for this:

1. The area of surface contact with the shaft is far greater than rolling element bearings, which have point-to-point contact with a given number of balls.
2. A rolling element bearing must be oriented properly for the ball tracks to carry the load adequately, while a Plain bearing can be mounted in any orientation.
3. Only one or two of the tracks in a rolling element bearing will actually carry any of the load applied.

Simplicity bearings have a thin liner that is bonded to a metal shell at the molecular level, allowing the load to be transferred throughout the bearing. This gives it an advantage over other Plain bearings of solid plastic or polymer materials. These other materials will tend to "cold flow" under pressure. "Cold flow" means to deform or lose shape. The idea is similar to pressing your finger into a bar of soap – material will move or deform as pressure is applied.

## Linear Surface Speeds (Velocity)

In typical applications, speed is a known quantity and easily converted. Typically feet per minute or meters per minute are used. The most important factor that speed (along with friction) produces is heat buildup. This is not a critical factor in most linear applications because the heat is dissipated over the length of travel, and it does not affect the bearing. Short stroke or extremely high speed applications may see the effects of heat buildup in thermal expansion and the bearing ID locking on the shaft. A compensated ID bearing (FLC) is recommended in these applications.

## Factors that Contribute to Wear Life

Plain bearings are rated by the wear rate of the bearing material. Wear is greatly dependent upon the proper application of the bearing and material used.

- Proper mating of shaft and liner materials.
- Surface finish 8-16 Ra (.20-.40 mm) is required. Peaks in the surface that are polished to a radius provide the best running surface. Sharp peaks in the finish will be like a fine lapping compound wearing the I.D. of the bearing.

**Note:** Shafting damaged by use with ball bearings can be salvaged and used with Simplicity bearings. Spin in a lathe and polish with sand papers in this order: 120 grit, 180 grit, and 300 grit. This will also remove sharp peaks in the surface finish.

- **Surface speed** - at high speeds, heat buildup will affect liner wear.
- **Break-in transfer** - proper transfer process of the liner to the shaft.
- **Lubrication** - proper lubrication can greatly improve the wear rate of a bearing. At the same time, improper lubrication can increase wear and failure.
- **Load & Wear Relationship** - wear rate is proportional to load to the third power: wear rate  $\propto (\text{load})^3$ .

If load is reduced to 1/2, wear will be reduced to  $(1/2)^3$ .

- **Contamination** - while migrating into the bearing and embedding into the liner, certain types of contamination may, over time, cause increased wear to the liner.

**Note:** This is not an all inclusive list. There are many more factors within an application that can affect wear to different degrees. These are the major issues and the first things to address in a design.

# Wear Rate Simplicity® Plain Bearings

## Wear Rate vs. Life Expectancy

A rolling element linear bearing's life expectancy is usually expressed in total inches or meters. A rolling element rotary bearing's life expectancy is expressed in hours of operation. Both are also rated for average (L-50) and minimum (L-10) life. L-50 life is the average life that can be expected from 50% of rolling element bearings. In other words, 50% will not reach the average life expectancy. L-10 life is the minimum life (1/5 the average life) expected from 90% of rolling element bearings. In other words, 10% will not reach the minimum life expectancy. Theoretically they could fail upon installation.

Plain bearings are not rated by a life expectancy but by the wear rate of the bearing material. Wear is greatly dependent upon the proper application of the bearing and material used. If it is not properly applied, it will fail. Failure, however, is subjective and dependent upon

specific application requirements. 0.002" running clearance may not be acceptable in one application while another may be able to run a bearing until the liner is completely worn through. The user may then rotate it 30 degrees and continue to run it. This broad range of acceptability makes it difficult to determine life expectancy.

The first step is to determine what wear is acceptable for your application. Then utilizing the test data below, you can estimate the wear expected for your given application.

### Wear Test Sample

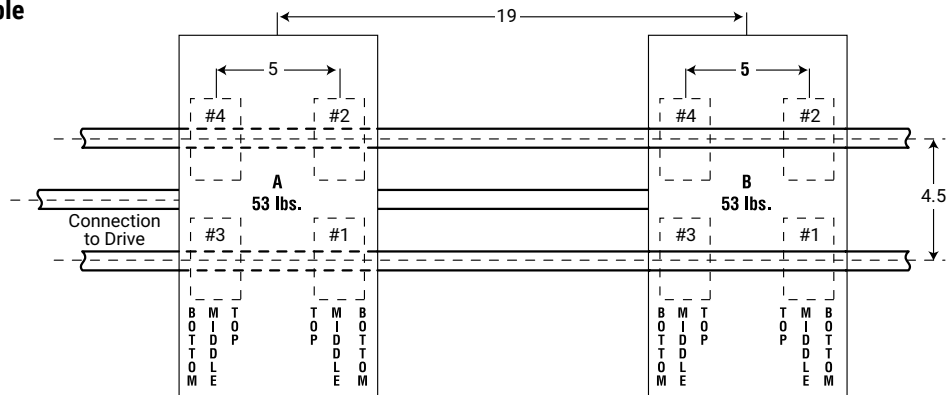

**Conducted by:** Pacific Bearing® Company

**Bearing Material:** FrelonGOLD®

**Shaft Material:** Standard RC60 steel shafting

**Surface Finish:** 8-12 Ra

**Speed:** 140 fpm (70 cycles/min.; 1,680"/min.;  
100,800"/hour; 2,419,200"/day)

**Stroke:** 12"

**Load:** 10.87 psi (53 lb.)

**Bearings Used:** FLN12 (3/4" open style bearings)

**Lubrication:** None

**Total Wear to Bearing Material:** FrelonGOLD = 0.00042"

**Note:** Wear is an average of totals taken from 4 bearings per carriage.

### FrelonGOLD® Linear Wear Test

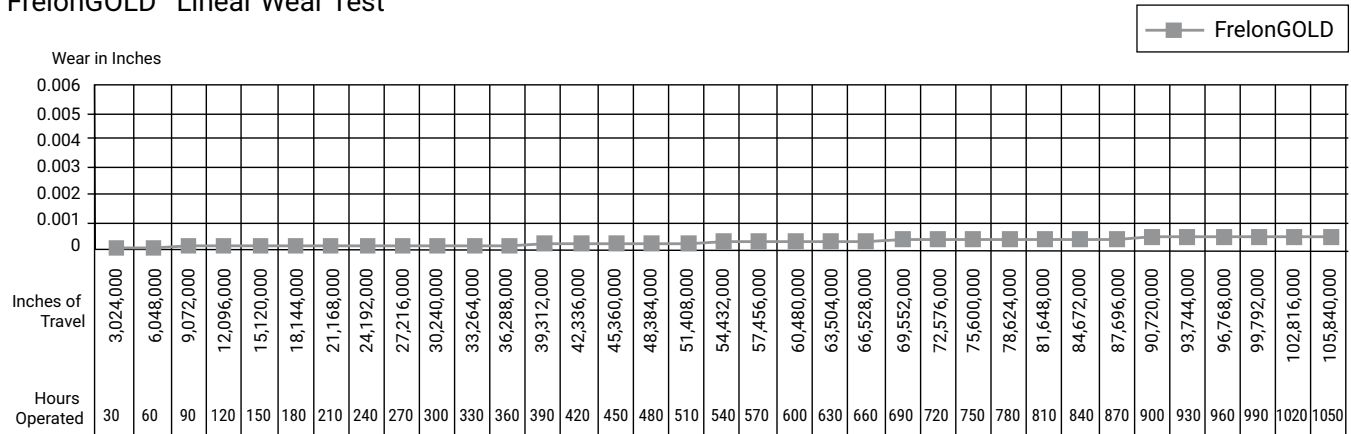

# Coefficient of Friction Simplicity® Plain Bearings

## Coefficient of Friction

A frequent misconception of Plain bearings is that wear and friction are basically synonymous, in that, high friction equals high wear or that low friction equals low wear. While there can be a relation between the two, they should be addressed as separate issues in the design process.

For example, dry running virgin (unfilled) PTFE on steel's coefficient of friction (c.o.f.) is approximately 0.1 while filled PTFE's c.o.f. can range from 0.125 to 0.4 depending on the fillers used. By comparison, however, the virgin PTFE will wear at a much greater rate.

### FRICION TEST SAMPLE #1

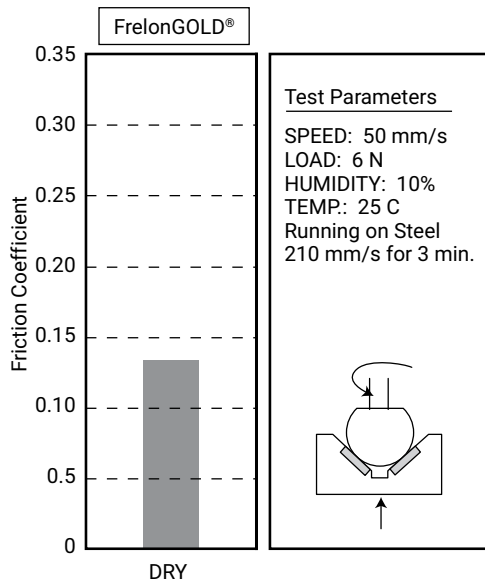

**Conducted by:** Dr. Tillwich GmbH

**Managing Director:** Mr. Werner Stehr (World leading tribologist with a seat on the ISOTC123 Committee establishing standards for tribological testing)

**Bearing Material:** FrelonGOLD®

**Shaft Material:** Standard RC60 steel shafting

**Surface Finish:** 8-12 Ra

**Speed:** 50 mm/sec.

**Load:** 6 N

**Temperature:** 25° C

**Lubrication:** None

**Average Coefficient of Friction:**  
 FrelonGOLD = 0.125

### FRICION TEST SAMPLE #2

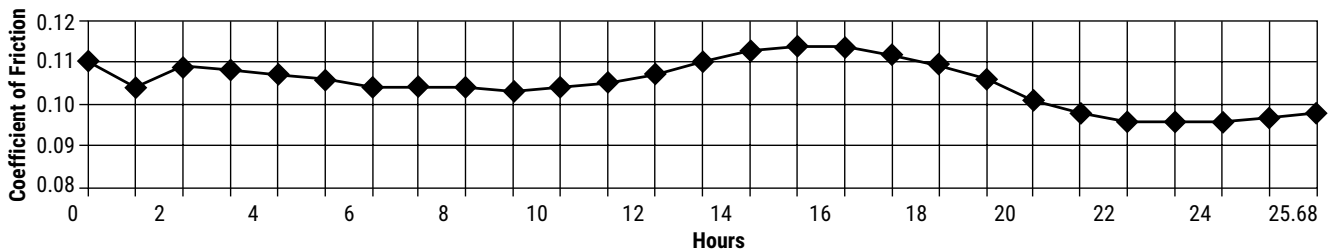

**Conducted by:** FrelonGOLD material processor

**Bearing Material:** FrelonGOLD

**Shaft Material:** CRS 1018

**Speed:** 100 fpm

**Load:** 100 psi

**Duration:** 25.68 hours

**Lubrication:** None

**Surface Finish:** 8 Ra

**Average COF:** 0.10

**Max. COF:** 0.15

**Min. COF:** 0.08

**Average Running Temperature:** 95.4° F

# Cantilevered Loads Simplicity® Plain Bearings

## Cantilevered Loads

- Maximum 2:1 ratio
- 1x = bearing separation on same shaft
- 2x = distance from shaft to load or force

**Example:** If 2x equals 10" then 1x must be at least 5"

**CAUTION** Binding will occur if the 2:1 ratio is exceeded!!

This principle is NOT load dependent. It is NOT due to edge loading. It is also NOT dependent on the driving force used. The bearings will bind whether hand or mechanically driven. This principle is a product of friction.

**Working through the following equation will explain why this is a product of friction:**

- P = force being applied
- L = distance out from shaft that P is being applied
- s = center to center spacing of bearings
- f = resultant force on bearings by shaft
- F = friction force on each bearing
- $\mu$  = coefficient of friction (about 0.25 when not moving)

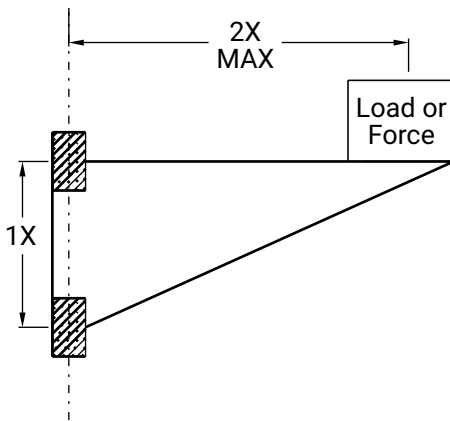

**Balance the moments:**  $f \cdot s = L \cdot P$   
 $L / s = f / P$

**Compute friction force:**  $F = f \cdot \mu$

**Note:** Total friction force pushing up is  $2 \cdot F$ . To lock up the slide, the total friction force must be equal to (or greater than) P.

$$P = 2 \cdot F = 2 \cdot f \cdot \mu$$

**Substitute for P:**

$$L / s = f / (2 \cdot f \cdot \mu) = 1 / (2 \cdot \mu) \Rightarrow L / s = 1 / (2 \cdot \mu)$$

**Note:** The forces drop out of the equation.

Assume static coefficient of friction is 0.25 ( $\mu = 0.25$ ) then  $L / s = 2$  That is the 2:1 ratio.

There may be other factors that add to the braking effect, but the coefficient of friction is the main cause.

**Note:** Proper lubrication can help to drop friction and extend the 2:1 ratio.

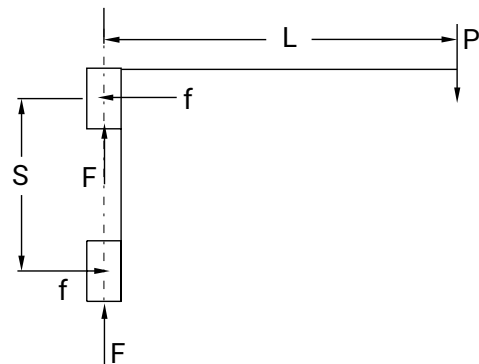

# Cantilevered Loads Simplicity® Plain Bearings

## Counterbalance

If holding the 2:1 ratio is not possible, one method of preventing binding problems is using a counter balance.

For efficient counter balances in horizontal applications, use this formula:  
 $M \cdot Y = W \cdot Z$

**Note:** To avoid problems when running without mass:

$$(M) Z = 1-1/2 s$$

W can be calculated. Load on bearing will be:

$$\frac{M + W}{\# \text{ of bearings}}$$

**Example:**  $50 \cdot 24 = W \cdot Z$  ( $Z = 1-1/2 \cdot 6 = 9$ )

$$W = \frac{50 \cdot 24}{9} = 133 \text{ lb.}$$

Load per bearing:  $\frac{50 + 133}{4} = 45.75 \text{ lb. / bearing}$

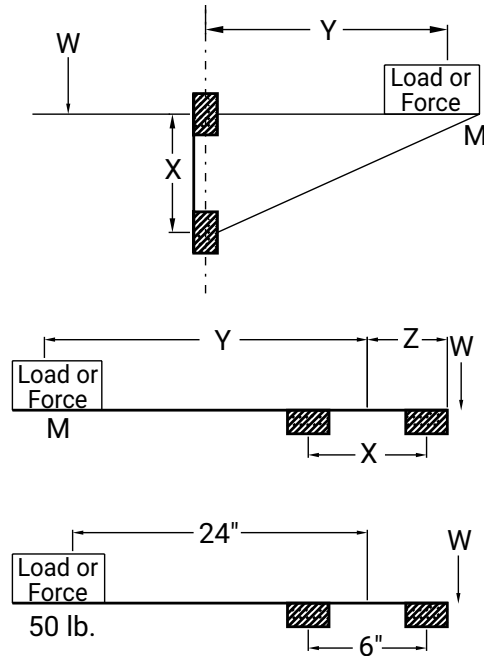

## Cantilever Loads and Drive Force Location without Counterbalance

d = distance from shaft to Drive Force

l = distance from shaft to the load center of gravity

s = center-to-center spacing of the bearings on the shaft  
 (If non-self-aligning, then outside to outside distance should be used.)

L = l / s = Load Force Ratio

D = d / s = Drive Force Ratio

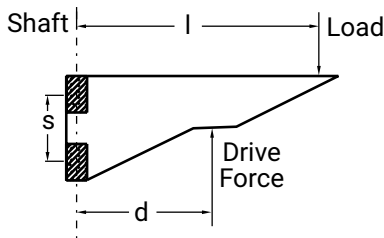

## Hanging or "Top Heavy" Horizontal Applications with High Acceleration Rates:

If your application will have high acceleration forces, use this formula for the value of the Drive Force Ratio:

$$D = 0.8 \cdot L \cdot a \quad \text{where } a \text{ is acceleration in g's.}$$

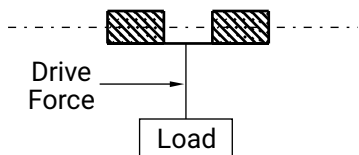

## General Rules:

1. Drive Force Ratio (D) should never be larger than 2. A Drive Force Ratio (D) larger than 2 can cause the slide to lock up.
2. Load Force Ratio (L) can be larger than 2, but as this ratio increases, the drive force required to move the slide increases dramatically. A Load Force Ratio (L) larger than 4 is not recommended.
3. If the slide is occasionally operated unloaded, use the distance to the slide's center of gravity as the distance to the load (l).

## Vertical Applications:

1. If L is between 0 and 2, the lowest drive forces occur when the value of D is about 90% of L ( $D = 0.9 \cdot L$ ). However, D values between 0 and L will work fine.
2. If L is between 2 and 4, use this equation:  $D = 4 - L$

## Horizontal Applications:

For best results, the drive force should be applied as close to the shaft as possible no matter what the value of the Load Force Ratio (L) is.

# Shaft Deflection

## Single Point Shaft Deflection

In applications where a support rail is not used, shaft deflection can become critical in the function of the bearing. If deflection is greater than the misalignment capabilities of a standard pillow block, binding can occur.

One solution would be to increase shaft and bearing size (to lessen the amount of deflection) or to use an open bearing configuration with a support rail.

Follow the formulas below to check shaft deflection and sag.

### Deflection at Center

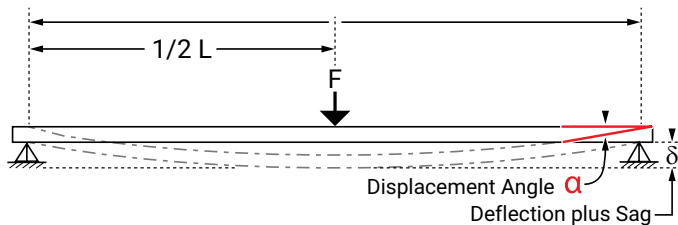

### Formula for Inch and Metric Shafting Deflection

Total shaft deflection in horizontal applications:

$$\text{Total Deflection } (\delta) = \text{Def} + \text{Sag} = \frac{FL^3}{48EI} + \frac{5wL^4}{384EI}$$

$$\text{Deflection} = (FL^3) / (48EI)$$

$$\text{Sag} = (5wL^4) / (384EI)$$

**Deflection** = Deflection due to load at center of shaft\*

**Sag** = Deflection of shaft due to its own weight\*

**L** = Shaft unsupported length\*

**F** = load being applied at center of shaft\*\*

**alpha** = Displacement angle

**EI** = (Modulus of Elasticity, **E**) • (Second Moment of Area, **I**)

**w** = Unit weight of shaft. (lb/in for inch shafts and N/mm for metric shafts)

\* inch for inch shafts, mm for metric shafts

\*\* lb for inch shafts, N for metric shafts

**Notes:**  $I = \pi \cdot \text{diam}^4 / 64$

$sw = \pi \cdot \text{diam}^2 / 4 \cdot \text{density}$

**E** = Modulus of Elasticity (Young's modulus)

## Total Deflection Example

ø1 in. Shaft

24 in. Length (L)

250 lb. load (W)

$$\text{Deflection} = \frac{F \cdot L^3}{48EI}$$

$$= \frac{250 \text{ lb.} \cdot (24 \text{ in.})^3}{48(1.45 \cdot 10^6) \text{ in.}^2 \text{ lb.}}$$

$$= \frac{3,456,000 \text{ in.}^3 \text{ lb.}}{69,600,000 \text{ in.}^2 \text{ lb.}}$$

$$\text{Deflection} = 0.0497 \text{ in.}$$

$$\text{SAG} = \frac{5wL^4}{384EI}$$

$$= \frac{5(0.222)(24^4) \text{ lb. in}^3}{384(1.45 \cdot 10^6) \text{ lb. in}^2}$$

$$\text{SAG} = \frac{368,271 \text{ lb. in}^3}{556,800,000 \text{ lb in}^2}$$

$$\text{SAG} = 0.000661 \text{ in.}$$

$$\begin{aligned} \text{Total Deflection } (\delta) &= \text{Deflection} + \text{SAG} \\ &= 0.0497 \text{ in.} + 0.000661 \text{ in.} \end{aligned}$$

$$\text{Total Deflection } (\delta) = 0.0504 \text{ in.}$$

# Shaft Deflection

## Two Point Shaft Deflection

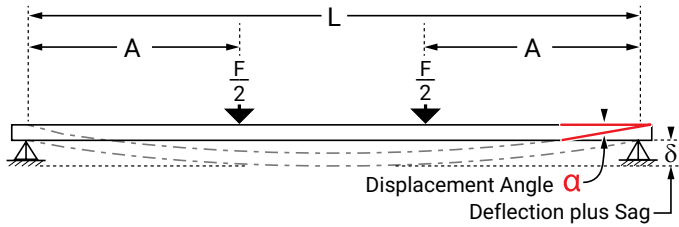

$$\delta = \frac{FA(3L^2 - 4A^2)}{48 EI} + \frac{5wL^4}{384 EI}$$

	Shaft Unit of measure	Inch	Metric
$\delta$	= Total Deflection	in.	mm
L	= Distance between the shaft support	in.	mm
E	= Modulus of elasticity	lb./in. <sup>2</sup>	N/mm <sup>2</sup>
I	= Shaft moment of inertia	in. <sup>4</sup>	mm <sup>4</sup>
w	= Unit weight of shaft (ref. table below)	lb./in.	N/mm
F	= Load applied (including carriage weight)	lb.	N
A	= Distance to end	in.	mm
a	= Displacement angle	deg.	deg.

## Inch Shafting

Shaft Diameter	Hardened Steel		Stainless Steel	
	EI LB·IN. <sup>2</sup>	w LB/IN.	EI LB·IN. <sup>2</sup>	w LB/IN.
3/16"	1.76E+03	0.0077	1.76E+03	7.70E-03
1/4"	5.60E+03	0.0138	5.59E+03	1.37E-02
3/8"	2.85E+04	0.0311	2.84E+04	3.10E-02
1/2"	9.04E+04	0.0553	9.01E+04	5.51E-02
5/8"	2.21E+05	0.0865	2.20E+05	8.62E-02
3/4"	4.59E+05	0.1250	4.57E+05	1.24E-01
7/8"	8.51E+05	0.1700	-	-
1"	1.45E+06	0.2220	1.45E+06	2.21E-01
1-1/8"	2.33E+06	0.2810	-	-
1-1/4"	3.55E+06	0.3470	3.54E+06	3.46E-01
1-3/8"	5.20E+06	0.4200	-	-
1-1/2"	7.36E+06	0.4990	7.33E+06	4.98E-01
1-3/4"	1.36E+07	0.6800	-	-
2"	2.33E+07	0.8880	2.32E+07	8.85E-01
2-1/2"	5.68E+07	1.3900	-	-
3"	1.18E+08	2.0000	-	-
4"	3.72E+08	3.5500	-	-

## Metric Shafting

Shaft Diameter	Hardened Steel		Stainless Steel	
	EI N·mm <sup>2</sup>	w N/mm	EI N·mm <sup>2</sup>	w N/mm
4 mm	2.54E+06	0.00096	2.53E+06	0.00096
5 mm	6.22E+06	0.00150	6.19E+06	0.00150
6 mm	1.29E+07	0.00217	1.29E+07	0.00216
8 mm	4.10E+07	0.00386	4.08E+07	0.00384
10 mm	1.00E+08	0.00603	9.96E+07	0.00601
12 mm	2.08E+08	0.00869	2.07E+08	0.00866
16 mm	6.57E+08	0.01550	6.54E+08	0.01540
20 mm	2.54E+09	0.02420	1.60E+09	0.02410
25 mm	3.92E+09	0.03780	3.90E+09	0.03760
30 mm	8.14E+09	0.05440	8.10E+09	0.05420
40 mm	2.57E+10	0.09670	2.56E+10	0.09640
50 mm	6.28E+10	0.15100	6.25E+10	0.15100
60 mm	1.30E+11	0.21800	-	-
80 mm	4.12E+11	0.38700	-	-

TECHNICAL

## Displacement Angle (values calculated on previous page)

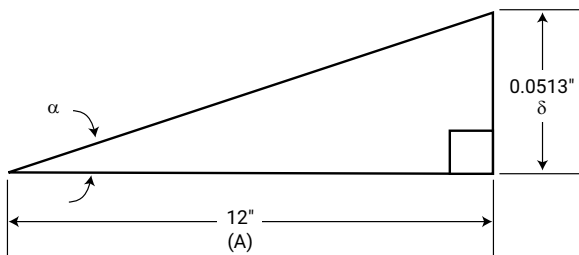

$$\pm = \tan^{-1} \frac{\delta}{A}$$

$$\pm = \tan^{-1} \frac{0.0504 \text{ in.}}{12 \text{ in.}}$$

$$\pm = 0.240^\circ \text{ Displacement Angle}$$

$$0.240^\circ < 1/2^\circ \text{ Allowable} = \text{Good Design}$$

# Installation Simplicity® Linear Plain Bearings

## Installing Simplicity® Bearings

Applies to standard linear bearing series.

For sleeve and flange bearings, see product pages 38–39, 60–62, 70–71, and 78–80.

### Straight Bore Housing – Press Fit Bearing

**This type of configuration is NOT recommended for the vast majority of applications using Simplicity bearings.**

**It does NOT allow for any misalignment or shaft deflection.**

Misalignment or shaft deflection will cause the bearing to bind on the shafting.

Extremely high precision applications may be able to employ this type of mounting. Typically the shafting has been aligned with a laser or some other highly precise equipment.

Due to bore closure in the pressing process, use a “C” series (compensated I.D.) bearing.

**Example:** FLC24, FMC30, FJC30.

The recommended installation procedure is to freeze the bearings at 0°F (-17.75°C) for 30-45 minutes. Using gloves, remove the bearings from the freezer and slip them into the housing. As they heat to room temperature, full contact between bearing and housing will be achieved. The greatest advantage to this technique over traditional pressing is greater accuracy in alignment.

This type of mounting will not allow for misalignment or shaft deflection. Both are very critical in the smooth operation of Simplicity bearings. A rolling element bearing may appear to initially operate in this condition, but it is operating in an extremely preloaded condition and will prematurely fail and in most cases destroy the shafting. Simplicity bearings will indicate the problem immediately upon installation by failing to move due to the binding condition. There are alternative mounting options that work extremely well.

Part No.	MIN Housing I.D. in.	MAX Housing I.D. in.	Part No.	MIN Housing I.D. mm	MAX Housing I.D. mm	Part No.	MIN Housing I.D. mm	MAX Housing I.D. mm	Part No.	MIN Housing I.D. mm	MAX Housing I.D. mm	Part No.	MIN Housing I.D. mm	MAX Housing I.D. mm
FLC03	0.3729	0.3737	FMC05	11.972	11.995	FMTC06	11.954	11.972	FGC06	11.952	11.970	FJC06	11.961	11.979
FLC04	0.4978	0.4986	FMC08	15.954	15.972	FMTC08	14.954	14.972	FGC08	14.952	14.970	FJHC08	14.961	14.979
FLC06	0.6228	0.6236	FMC10	18.948	18.969	FMTC10	16.954	16.972	FGC10	16.952	16.970	FJC08	14.961	14.979
FLC08	0.8725	0.8734	FMC12	21.944	21.965	FMTC12	18.948	18.969	FGC12	21.945	21.966	FJC10	18.952	18.973
FLC10	1.1224	1.1234	FMC16	25.944	25.965	FMTC14	20.944	20.965	FGC15	24.945	24.966	FJC12	20.952	20.997
FLC12	1.2474	1.2484	FMC20	31.940	31.961	FMTC16	23.944	23.965	FGC16	25.945	25.966	FJC13	22.952	22.973
FLC16	1.5596	1.5607	FMC25	39.932	39.957	FMTC20	27.944	27.965	FGC18	27.945	27.966	FJC16	27.952	27.973
FLC20	1.9970	1.9981	FMC30	46.932	46.957	FMTC25	34.940	34.961	FGC20	31.945	31.966	FJC20	31.950	31.971
FLC24	2.3717	2.3729	FMC40	61.917	61.947	FMTC30	39.932	39.957	FGC25	39.937	39.962	FJC25	39.941	39.966
FLC32	2.9965	2.9977	FMC50	74.917	74.947	FMTC40	51.932	51.957	FGC30	44.937	44.962	FJC30	44.941	44.966
FLC40	3.7461	3.7473	FMC60	89.906	89.936	FMTC50	61.917	61.947	FGC35	51.937	51.962	FJC35	51.938	51.963
FLC48	4.4953	4.4966	FMC80	119.886	119.921				FGC40	59.927	59.957	FJC38	56.938	56.963
FLC64	5.9949	5.9963							FGC50	74.927	74.957	FJC40	59.928	59.958
												FJC50	79.922	79.952
												FJC60	89.919	89.949
												FJC80	119.899	119.934
												FJC100	149.896	149.931
												FJC120	179.875	179.915
												FJC150	209.849	209.895

TECHNICAL

# Installation Simplicity® Linear Plain Bearings

## Straight Bore Housing - Slip Fit Bearing

There are three basic configurations that work well, depending on the misalignment and shaft deflection in the application:

### 1. Virtually NO misalignment

This method allows for NO or very little shaft deflection and misalignment. Standard I.D. bearings will need tighter alignment than a "C" series (compensated I.D.) bearing. Standard retention methods are acceptable.

**Example:** snap rings, epoxy, etc.

**Note:** If using epoxy, do not touch the bearing liner with the bonding agent.

This type of mounting will allow for minimum misalignment or shaft deflection. Both are very critical in the smooth operation of Simplicity bearings. A rolling element bearing may appear to initially operate in this condition, but it is operating in an extremely preloaded condition and will prematurely fail and in most cases destroy the shafting. Simplicity bearings will indicate the problem immediately upon installation by failing to move due to the binding condition.

Part No.	MIN Housing I.D. in.	MAX Housing I.D. in.	Part No.	MIN Housing I.D. mm	MAX Housing I.D. mm	Part No.	MIN Housing I.D. mm	MAX Housing I.D. mm	Part No.	MIN Housing I.D. mm	MAX Housing I.D. mm	Part No.	MIN Housing I.D. mm	MAX Housing I.D. mm
FL03	0.3755	0.3764	FM05	12.016	12.043	FMT06	12.016	12.043	FG06	12.016	12.043	FJ06	12.016	12.043
FL04	0.5006	0.5017	FM08	16.016	16.043	FMT08	15.016	15.043	FG08	15.016	15.043	FJH08	15.016	15.043
FL06	0.6256	0.6267	FM10	19.020	19.053	FMT10	17.016	17.043	FG10	17.016	17.043	FJ08	15.016	15.043
FL08	0.8758	0.8771	FM12	22.020	22.053	FMT12	19.020	19.053	FG12	22.020	22.053	FJ10	19.020	19.053
FL10	1.1258	1.1271	FM16	26.020	26.053	FMT14	21.020	21.053	FG15	25.020	25.053	FJ12	21.020	21.053
FL12	1.2510	1.2525	FM20	32.025	32.064	FMT16	24.020	24.053	FG16	26.020	26.053	FJ13	23.020	23.053
FL16	1.5635	1.5650	FM25	40.025	40.064	FMT20	28.020	28.053	FG18	28.020	28.053	FJ16	28.020	28.053
FL20	2.0012	2.0030	FM30	47.025	47.064	FMT25	35.025	35.064	FG20	32.025	32.064	FJ20	32.025	32.064
FL24	2.3762	2.3780	FM40	62.030	60.076	FMT30	40.025	40.064	FG25	40.025	40.064	FJ25	40.025	40.064
FL32	3.0012	3.0030	FM50	75.030	75.076	FMT40	52.030	52.076	FG30	45.025	45.064	FJ30	45.025	45.064
FL40	3.7514	3.7535	FM60	90.036	90.090	FMT50	62.030	62.076	FG35	52.030	52.076	FJ35	52.030	52.076
FL48	4.5014	4.5035	FM80	120.036	120.090				FG40	60.030	60.076	FJ38	57.030	57.076
FL64	6.0017	6.0042							FG50	75.030	75.076	FJ40	60.030	60.076
												FJ50	80.030	80.076
												FJ60	90.036	90.090
												FJ80	120.036	120.090
												FJ100	150.043	150.106
												FJ120	180.043	180.106
												FJ150	210.050	210.122

# Installation Simplicity® Linear Plain Bearings

## Straight Bore Housing – Slip Fit Bearing

### 2. Standard applications with average misalignment

A self-aligning O.D. bearing is recommended. **Example:** FLA24, FMA30, FJA30.

The recommended method of retention for this mounting is a snap ring at each end.

**Note:** Do not use epoxy in this configuration. It will lock the bearing in place not allowing it to self-align. Be sure to install the o-rings around the O.D. of the bearing to reduce noise while the bearing is in operation. FMT and FG series are NOT available with a self-aligning O.D.

Part No.	MIN Housing I.D. in.	MAX Housing I.D. in.	Part No.	MIN Housing I.D. mm	MAX Housing I.D. mm	Part No.	MIN Housing I.D. mm	MAX Housing I.D. mm	Part No.	MIN Housing I.D. mm	MAX Housing I.D. mm	Part No.	MIN Housing I.D. mm	MAX Housing I.D. mm
FLA03	0.3755	0.3764	FMA05	12.016	12.043	FMT06	N/A	N/A	FG06	N/A	N/A	FJA06	12.016	12.043
FLA04	0.5006	0.5017	FMA08	16.016	16.043	FMT08	N/A	N/A	FG08	N/A	N/A	FJHA08	15.016	15.043
FLA06	0.6256	0.6267	FMA10	19.020	19.053	FMT10	N/A	N/A	FG10	N/A	N/A	FJA08	15.016	15.043
FLA08	0.8758	0.8771	FMA12	22.020	22.053	FMT12	N/A	N/A	FG12	N/A	N/A	FJA10	19.020	19.053
FLA10	1.1258	1.1271	FMA16	26.020	26.053	FMT14	N/A	N/A	FG15	N/A	N/A	FJA12	21.020	21.053
FLA12	1.2510	1.2525	FMA20	32.025	32.064	FMT16	N/A	N/A	FG16	N/A	N/A	FJA13	23.020	23.053
FLA16	1.5635	1.5650	FMA25	40.025	40.064	FMT20	N/A	N/A	FG18	N/A	N/A	FJA16	28.020	28.053
FLA20	2.0012	2.0030	FMA30	47.025	47.064	FMT25	N/A	N/A	FG20	N/A	N/A	FJA20	32.025	32.064
FLA24	2.3762	2.3780	FMA40	62.030	60.076	FMT30	N/A	N/A	FG25	N/A	N/A	FJA25	40.025	40.064
FLA32	3.0012	3.0030	FMA50	75.030	75.076	FMT40	N/A	N/A	FG30	N/A	N/A	FJA30	45.025	45.064
FLA40	3.7514	3.7535	FMA60	90.036	90.090	FMT50	N/A	N/A	FG35	N/A	N/A	FJA35	52.030	52.076
FLA48	4.5014	4.5035	FMA80	120.036	120.090				FG40	N/A	N/A	FJA38	57.030	57.076
FLA64	6.0017	6.0042							FG50	N/A	N/A	FJA40	60.030	60.076
												FJA50	80.030	80.076
												FJA60	90.036	90.090
												FJA80	120.036	120.090
												FJA100	150.043	150.106
												FJA120	180.043	180.106
												FJA150	210.050	210.122

TECHNICAL

# Installation Simplicity® Linear Plain Bearings

## Straight Bore Housing – Slip Fit Bearing

### 3. Severe misalignment

#### POSSIBLE SOLUTIONS for use with Standard “FL”:

1. Undersize the bearing O.D. (see chart) and install o-rings.
2. Oversize the housing I.D. (see chart) and install the standard bearing with o-rings.

The additional clearance created by either method will allow the bearing to float in the housing and match the non-parallelism of the shafting.

**CAUTION** This solution is only for SEVERE cases that the standard self-aligning will not accommodate.

The recommended method of retention for this mounting is a snap ring at each end. Accessories, including o-rings can be found on [page 29](#).

**Note:** Do not use epoxy in this configuration. It will lock the bearing in place, not allowing it to self-align.

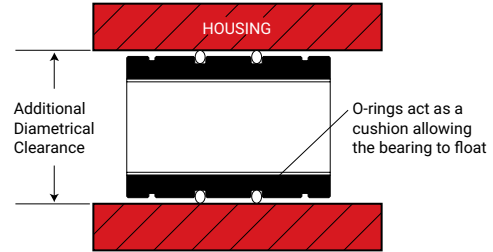

Part No.	MAX Additional Clearance in.	Part No.	MAX Additional Clearance mm	Part No.	MAX Additional Clearance mm	Part No.	MAX Additional Clearance mm	Part No.	MAX Additional Clearance mm
FL03	0.0070	FM05	0.203	FMT06	0.203	FG06	0.203	FJ06	0.203
FL04	0.0080	FM08	0.203	FMT08	0.203	FG08	0.203	FJ08	0.203
FL06	0.0080	FM10	0.203	FMT10	0.203	FG10	0.203	FJ10	0.203
FL08	0.0080	FM12	0.203	FMT12	0.203	FG12	0.203	FJ12	0.203
FL10	0.0100	FM16	0.254	FMT14	0.203	FG15	0.254	FJ13	0.203
FL12	0.0100	FM20	0.254	FMT16	0.254	FG16	0.254	FJ16	0.254
FL16	0.0120	FM25	0.305	FMT20	0.254	FG18	0.254	FJ20	0.254
FL20	0.0120	FM30	0.305	FMT25	0.254	FG20	0.254	FJ25	0.305
FL24	0.0120	FM40	0.305	FMT30	0.305	FG25	0.305	FJ30	0.305
FL32	0.0120	FM50	0.305	FMT40	0.305	FG30	0.305	FJ35	0.305
FL40	0.0160	FM60	0.406	FMT50	0.305	FG35	0.305	FJ38	0.305
FL48	0.0160	FM80	0.508			FG40	0.305	FJ40	0.305
FL64	0.0200					FG50	0.305	FJ50	0.406
								FJ60	0.406
								FJ80	0.508
								FJ100	0.610
								FJ120	0.610
								FJ150	0.610

# Chemical Reaction Chart

The original Frelon® J has almost universal chemical inertness. Only molten sodium and fluorine at elevated temperatures and pressures show any signs of attack. It is approved for use with liquid oxygen, N2O2 hydrazine, UDMH, hydrocarbon fuels, high strength hydrogen peroxide, etc.

The FrelonGOLD® material is a composite of PTFE and a bearing filler. The PTFE is chemically inert. The chemical resistance shown in the chart below is defined by the compatibility of the filler with the various chemicals.

Other data in the chart below applies to the bearing shell and pillow block materials. The table is provided as a reference only. The data given will be affected by factors such as temperature, PV, degree of contact, strength of solution, etc. In each specific application, it is always advisable to conduct specific testing to determine suitability of use. This table only addresses general corrosion, NOT galvanic, SCC, or other types of corrosion. Corrosion rates are at room temperature unless otherwise noted.

Standard and hard coat data only apply when the coating is intact. If the coating is worn through or damaged, an area of galvanic and pitting corrosion will be created. Then use the bare aluminum data.

Standard Simplicity® products use aluminum alloy, which is known to have the best corrosion resistance of the high strength aluminum alloys. The sulfuric bath anodizing and nickel acetate sealing provide the best corrosion

resistance available in anodized coatings. They can withstand a rigorous 14-day exposure in a 5% salt spray solution at 96°F per military specifications without significant damage. With the coating intact, it is considered to be inert in most fluids with a pH value between 5 and 8. Hard coat anodizing provides the same chemical resistance but is applied to a 0.002" thickness, providing a more durable surface that will stand up to greater abuse. However, if the coating is penetrated, the resistance is reduced.

Special stainless steel bearings use AISI 316 stainless, which has superior resistance over 303, 304, 420, 440, 17-4PH, and most other common stainless grades. 316 is generally considered to be the most corrosion resistant of conventional stainless steels.

**Note:** This information was compiled for Pacific Bearing® Company by Materials Engineering, Inc. of Virgil, IL. This specification information is believed to be accurate and reliable, however, no liability is assumed. Information is for reference only. User must test specific applications.

Performance	Wear
E = Excellent	< 0.002" per year
G = Good	< 0.020" per year
S = Satisfactory	< 0.050" per year
U = Unsatisfactory	> 0.040" per year

Chemical	Frelon GOLD	Bare Aluminum	Standard & Hard Coat Anodized Aluminum	316 Stainless Steel
Acetic Acid, 20%	U	G	G	E
Acetone	G	E	E	E
Ammonia, Anhydrous	G	E	E	E
Ammonium Hydroxide, 10%	U	U	U	E
Ammonium Chloride, 10%	U	U	U	G
Ammyl Acetate (122°F / 50°C)	G	E	E	E
Barium Hydroxide	U	U	U	G
Beer	G	E	E	E
Boric Acid Solutions	G	E	E	G
Butane	G	G	G	G
Calcium Chloride, 20%	G	G	G	G
Calcium Hydroxide, 10%	G	G	G	G
Carbon Dioxide	G	E	E	G
Carbon Monoxide	G	E	E	E
Chlorine Gas, Dry	G	G	G	G
Chlorine Gas, Wet	U	U	U	U
Chromic Acid, 10%	U	G	E	E
Citric Acid, 5%	G	E	E	E
Ethyl Acetate	G	E	E	G
Ethyl Alcohol	G	E	E	G
Ethylene Glycol	G	E	E	G
Ferric Chloride, 50%	U	U	U	U
Formic Acid - Anhydrous	U	E	E	E
Gasoline, Unleaded	G	G	G	G
Hydrochloric Acid, 20%	U	U	U	U
Hydrochloric Acid, 35%	U	U	U	U
Hydrocyanic Acid, 10%	U	G	G	G
Hydrofluoric Acid - Dilute	U	U	U	U
Hydrofluoric Acid, 48%	U	U	U	U
Hydrogen	G	E	E	E
Hydrogen Peroxide - Dilute	U	E	E	G

Chemical	Frelon GOLD	Bare Aluminum	Standard & Hard Coat Anodized Aluminum	316 Stainless Steel
Hydrogen Sulfide, Dry	U	G	E	E
JP-4	G	G	G	G
Kerosene	G	G	G	G
Lactic Acid, 10%	G	G	G	E
Magnesium Chloride, 50%	G	U	U	G
Mercury	U	U	U	E
Methyl Alcohol	G	G	G	G
Methyl Ethyl Ketone	G	G	G	G
Methylene Chloride	G	E	E	G
Mineral Oil	G	G	G	G
Naptha	G	G	G	G
Nitric Acid, 70%	U	U	U	E
Phosphoric Acid, 10%	U	U	U	E
Sodium Chloride	G	U	U	E
Sodium Hydroxide, 20%	G	U	U	G
Sodium Hypochlorite, 20%	U	G	G	U
Sodium Peroxide, 10%	U	G	G	G
Steam (see water)	-	-	-	-
Sulfur Dioxide, Wet	U	U	U	G
Sulfur Dioxide, Dry	G	G	G	G
Sulfur Trioxide	U	G	G	G
Sulfuric Acid, 50%	U	U	U	U
Sulfurous Acid	U	G	G	E
Toluene (122°F / 50°C)	G	E	E	E
Turpentine	G	G	E	E
Water, Demineralized	U	G	E	E
Water, Distilled	G	U	S	G
Sea Water	G	G	E	G
Water, Sewage	G	U	S	G
Xylene	G	G	G	G
Zinc Chloride Solutions	U	U	U	G

TECHNICAL

# Linear Ball Bearings Technical Information

## Load Rating and Life Expectancy

The life (L) of a linear bearing can be obtained from the following equation with the basic dynamic load rating and the load applied to the bearing:

$$L = \left( \frac{f_H \cdot f_T \cdot f_C \cdot C}{f_W \cdot P} \right)^3 \cdot 50 \quad (1)$$

- L:** Rated life (km)
- C:** Basic dynamic load rating (N/lbf)
- P:** Working load (N/lbf)
- f<sub>W</sub>:** Load coefficient
- f<sub>H</sub>:** Hardness factor
- f<sub>T</sub>:** Temperature coefficient
- f<sub>C</sub>:** Contact coefficient

The lifespan (L<sub>h</sub>) of a linear ball bearing in hours can be obtained by calculating the traveling distance per unit time. The lifespan can be obtained from the following equation if the stroke length and the number of strokes are constant:

$$L_h = \left( \frac{L \cdot 10^3}{2 \cdot s \cdot n_1 \cdot 60} \right) \quad (2)$$

- L<sub>h</sub>:** Lifespan (hr)
- L:** Rated life (km)
- s:** Stroke length (m)
- n<sub>1</sub>:** Number of strokes per minute (cpm)
- 50:** Constant base line (km)

## Relation Between Ball Circuits and Load Rating

Linear ball bearings are constructed so that the ball circuits are spaced equally. The load rating varies according to the loaded position. The load ratings of the linear ball bearings from the dimensional tables are per track and increased loading can be achieved by equally sharing the load between the tracks.

The table shows the increased value by the number of ball circuits in such cases.

- Notes:** (1) 3 track bearing is equal.
- (2) Open bearing load is de-rated by 50% if going against the opening.

Number of Rows	4	5	6
Co			
Load Rating Specified on the Tables			
Co <sub>max</sub>			
MAX Load Rating			
Load Ratio Co <sub>max</sub> /Co	1.414	1.463	1.280

## Sample Calculations

1. Obtaining the rated life L and lifespan L<sub>h</sub> of the Simplicity® linear ball bearing used in the following conditions:

- Linear ball bearing: EP20G
- Stroke length: 50 mm
- Number of strokes per minute: 50 cpm
- Load per bush: 490 N

The basic dynamic load rating of the linear ball bearing is 860 N from the dimension tables on page 79. From equation (1), therefore, the rated life L is obtained as follows:

$$L = \left( \frac{f_H \cdot f_T \cdot f_C \cdot C}{f_W \cdot P} \right)^3 \cdot 50 \quad f_H=f_T=f_C=f_W=1.0$$

$$= \left( \frac{860}{490} \right)^3 \cdot 50 = 270 \text{ km}$$

From equation (2), the lifespan L<sub>h</sub> is obtained as follows:

$$L_h = \frac{L \cdot 10^3}{2 \cdot s \cdot n_1 \cdot 60} = \frac{270 \cdot 10^3}{2 \cdot 0.05 \cdot 50 \cdot 60} = 901 \text{ hr}$$

2. Select the ball bearing type by satisfying the following conditions:

- Number of linear bushing used 4
- Stroke length 1 m
- Traveling speed 10 m/min.
- Number of strokes per minute 5 cpm
- Lifespan 10,000 hr
- Total load 980 N

From equation (2), the traveling distance within the lifespan is obtained as follows:

$$L = 2 \cdot s \cdot n_1 \cdot 60 \cdot L_h = 6,000 \text{ km}$$

From equation (1), the basic dynamic load rating is obtained as follows:

$$C = \sqrt[3]{\frac{L}{50} \cdot \left( \frac{f_W}{f_H \cdot f_T \cdot f_C} \right) \cdot P} = 1492 \text{ N}$$

Assume the following with a pair of shafts each with two linear ball bearings: f<sub>C</sub> = 0.81 f<sub>W</sub> = f<sub>T</sub> = f<sub>H</sub> = 1

As a result, EP20G is selected from the dimension table as the Simplicity® linear ball bearing type satisfying the value of C.

# Load Rating & Rating Life Linear Ball Bearings

## Load Rating

### Basic Dynamic Load Rating (C) –

This term is arrived at based on an evaluation of a number of identical linear systems individually run in the same conditions, if 90% of them can run with the load (with a constant value in a constant direction) for a distance of 50 km without damage caused by rolling fatigue. This is the basis of the rating.

### Allowable Static Moment (M) –

This term defines the allowable limit value of static moment load, with reference to the amount of permanent deformation similar to that used for evaluation of basic rated load (Co).

### Static Safety Factor (fs) –

This factor is used based on the application condition.

### STATIC SAFETY FACTORS Table 1

Condition of use	Low Limit of fs
When the shaft has less deflection and shock	1 to 2
When elastic deformation should be considered with respect to cantilever load	2 to 4
When the equipment is subject to vibration and impacts	3 to 5

### Basic Static Load Rating (Co) –

This term defines a static load such that, at the contacting position where the maximum stress is exercised, the sum of the permanent deformation of the rolling elements and that of the rolling plain is 0.0001 times of the diameter of the rolling elements.

## Rating Life

### Rating Life of the Linear System

As long as the linear system reciprocates while being loaded, continuous stress can cause flaking on the rolling bodies and planes due to material fatigue. The system's distance of travel until the first flaking occurs is called the life of the system. The life of the system varies even when similar conditions are used – dimensions, structure, material, heat treatment, and processing method. The material fatigue causes the essential variations. The rating life defined below is used as an index for the life expectancy of the linear system.

### Rating Life (L)

Rating life is the total travelling distance that 90% of a group of systems of the same size can reach without causing any flaking when they operate under the same conditions. The rating life can be obtained from the following equation with the basic dynamic load rating and the load on the linear system:

For ball type:

$$L = \left(\frac{C}{p}\right)^3 \cdot 50 \quad (1)$$

L: Rating life (km)

C: Basic dynamic load rating (N)

p: Load (N)

Consideration and influence of vibration impact loads and distribution of load should be taken into account when designing a linear motion system. It is difficult to calculate the actual load. The rating life is also affected by the operating temperature. In these conditions, the expression (1) is arranged as follows:

$$L = \left(\frac{f_H \cdot f_T \cdot f_C \cdot C}{f_W \cdot p}\right)^3 \cdot 50$$

For ball type:

L: Rating life (km)

f<sub>H</sub>: Hardness factor (See Fig.1)

C: Basic dynamic load rating (N)

f<sub>T</sub>: Temperature coefficient (See Fig.2)

p: Load (N)

f<sub>C</sub>: Contact coefficient (See Table 2)

f<sub>W</sub>: Load coefficient (See Table 3)

The rating life in hours can be calculated by obtaining the travelling distance per unit time. The rating life in hours can be obtained from the following expression when the stroke length and the number of strokes are constant:

$$L_h = \left(\frac{L \cdot 10^3}{2\ell_s \cdot n_1 \cdot 60}\right)$$

L<sub>h</sub> : Rating life in hours (hr)

ℓ<sub>s</sub> : Stroke length (m)

L : Rating life (km)

n<sub>1</sub> : No. of strokes per minute (cpm)

# Rating Life Linear Ball Bearings

## Rating Life

### Hardness Factor (fH)

The shaft must be sufficiently hardened when a linear bushing is used. If not properly hardened, permissible load is lowered and the life of the linear ball bearings will be shortened.

FIG. 1

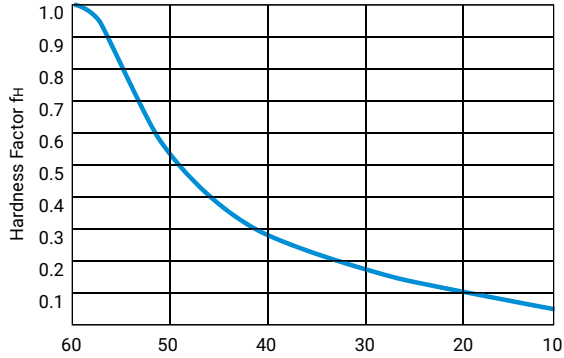

### Temperature Coefficient (fT)

If the temperature of the linear system exceeds 100°C, hardness of the linear system and the shaft lowers to decrease the permissible load compared to that of the linear system used at room temperature. As a result, the abnormal temperature rise shortens the rating life.

FIG. 2

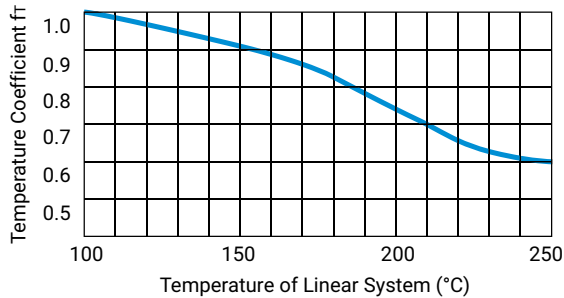

**Notes:** Maximum temperature of plastic retainer 212°F or 100°C.  
Maximum temperature 176° per Table 6 on page 134.

### Contact Coefficient (fc) – Table 2

Generally two or more linear bearings are used on one shaft. Thus, the load on each linear system differs depending on each processing accuracy. Because the linear bushings are not loaded equally, the number of linear bushings per shaft changes the permissible load off the system.

CONTACT COEFFICIENT Table 2

Number of Linear Systems per Shaft	Contact coefficient - FC
1	1.00
2	0.81
3	0.72
4	0.66
5	0.61

### Load Coefficient (fw) – Table 3

When calculating the load on the linear system, it is necessary to accurately obtain object weight, inertial force based on motion speed, moment load, and each transition as time passes. However, it is difficult to calculate those values accurately because reciprocating motion involves the repetition of start and stop as well as vibration and impact. A more practical approach is to obtain the load coefficient by taking the actual operating conditions into account.

LOAD COEFFICIENT Table 3

Operating Conditions	FW
Operation at low speed (15 m/min. or less) without impulsive shock from outside	1.0 to 1.5
Operation at intermediate speed (60 m/min. or less) without impulsive shock	1.5 to 2.0
Operation at high speed (over 60 m/min.) with impulsive shock from outside	2.0 to 3.5

# Clearance & Mounting Linear Ball Bearings

## Clearance & Fit

Standard-type Simplicity® linear ball bearings matched to a shaft that provides inadequate clearance may result in early bearing failure and/or rough linear motion. The clearance adjustable linear ball bearings and open linear ball bearings can be adjusted when assembled in the housing by controlling the housing bore. However, too much clearance

will increase the deformation of the linear ball bearing, which will affect its precision and life. Therefore, the appropriate clearance between the ball bearing and shaft, and the appropriate linear ball bearing housing bore are required based on application.

## RECOMMENDED FIT OF LINEAR BALL BEARINGS

Model	Division	Shaft		Housing	
		Normal Fit	Transitional	Loose Fit	Tight Fit
JP	High Precision	g6	h6	H7	J7
IP	High Precision	g6	h6	H7	J7
EP	High Precision	h6	j6	H7	J7

## Shaft & Housing

To optimize performance of the Simplicity® linear ball bearing it is recommended that a high precision shaft and pillow block are required.

### Shaft

The rolling balls in linear ball bearings are in-line contact with the shaft surface. Therefore, the shaft dimensions, tolerance, surface finish, and hardness greatly affect the performance of the linear ball bearing. The shaft should be manufactured to the following tolerances:

1. Surface finish critically affects the smooth rolling of balls; shaft surface finish should be Ra 8-10.

2. Shaft hardness should be HRC 60 to 64. Hardness less than HRC 60 will decrease the life/load.

3. Preload increases the frictional resistance slightly. If the preload is too tight, the deformation of the bearing sleeve will shorten the linear ball bearing's life.

### Housing

There are a wide variety of housings differing in design, machining, and mounting. See mounting requirements below.

## Mounting

When inserting the linear ball bearing into the housing, do not hit the linear ball bearing on the end-retaining ring, but apply pressure either by hand or arbor on the linear ball bearing sleeve (See Fig.1) To insert the shaft into the mounted linear ball bearing, make sure the shaft is chamfered and be careful not to push on the balls by inserting the shaft at an angle.

**Note:** If two shafts are used in parallel, the parallelism is an important factor to assure smooth linear movement and not damage the linear ball bearings.

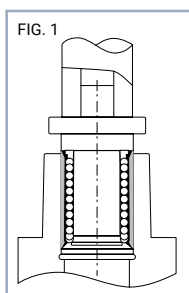

## Examples of Mounting

The popular way to mount linear ball bearings is with a slight preload. PBC Linear recommends a slight clearance fit-up to ensure proper life. The examples, Figs. 2 to 6, show the inserted linear ball bearing using a variety of retention methods.

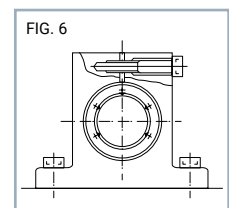
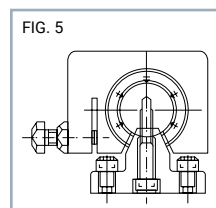
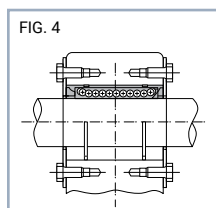
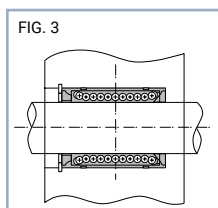
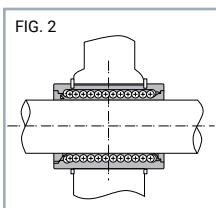

# Clearance & Mounting Linear Ball Bearings

## Frictional Resistance

The static frictional resistance of the Simplicity® linear system is so low that it is only slightly different from the kinetic frictional resistance, enabling smooth linear movement from low to high speeds. In general, the frictional resistance is expressed by the following equation.

$$F = \mu \cdot W + f$$

F : Frictional resistance     $\mu$  : Coefficient of friction

W : Load weight            f : Sealing resistance

The frictional resistance of each PBC Linear system depends on the model, load weight, speed, and lubricant. The sealing resistance depends on the lip interference and lubricant, regardless of the load weight. The sealing resistance of one linear system is about 200 to 500 gf. The coefficient of friction depends on the load weight, moment load, and preload.

COEFFICIENT OF LINEAR SYSTEM FRICTION ( $\mu$ ) Table 5

Linear System Type	Models	Coefficient of Friction ( $\mu$ )
Linear Bearing	JP, EP, IP	0.002 to 0.003

## Ambient Working Temperature

The ambient working temperature range for each PBC linear system depends on the model. Consult PBC Linear on use outside the recommended temperature range.

Temperature conversion equation:

$$C = \frac{5}{9}(F - 32) \quad F = 32 + \frac{9}{5}C$$

AMBIENT WORKING TEMPERATURE Table 6

Linear System Type	Models	Ambient Working Temperature
Linear Ball Bearing	JP, EP, IP	-20 to 80°C, -4 to 176°F

## Lubrication and Dust Prevention

Using PBC Linear systems without lubrication increases the abrasion of the rolling elements, shortening the life span. Systems, therefore, require appropriate lubrication. PBC Linear ball bearings are shipped with an anti-corrosion treatment, which must be cleaned prior to applying grease or oil. For lubrication, PBC Linear recommends turbine oil conforming to ISO Standards G32 to G68 or lithium base soap grease No.2. Prior to usage, apply lubricant directly inside the linear bearing and shaft, and re-lubricate periodically according to the operating conditions. Some systems from PBC Linear are sealed to block dust out and seal lubricant in. If used in a harsh or corrosive environment a protective cover should be used.

# Loads Roller Pillow Block Bearings

## Orientation & Cantilever Loads

When a linear motion system is subjected to a cantilever load or moment, the system designer must take into consideration these type of loads will greatly affect the performance of the system. Roller Pillow Blocks are not suitable for these types of applications because the moments will load the side rollers and cause premature failure. If the moments or cantilever loads are minor, loads may be acceptable. For this reason we ask that you consult the factory.

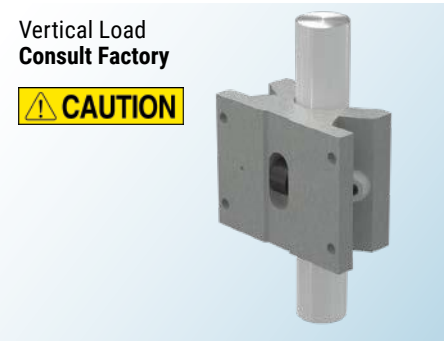
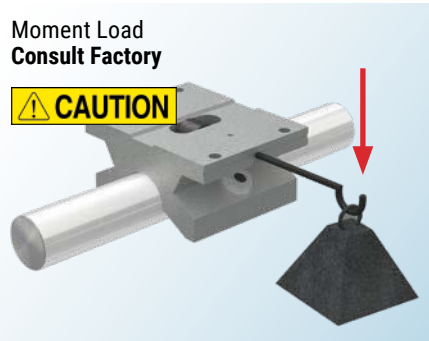
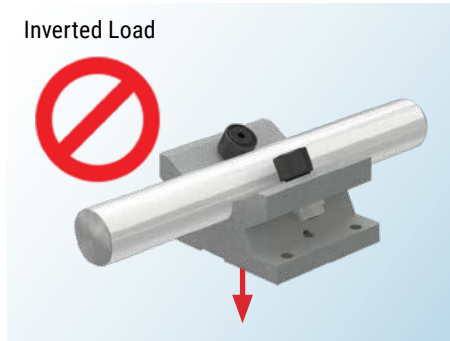
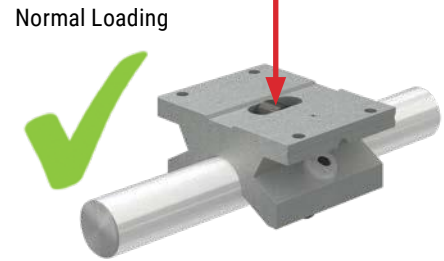

 Consult Factory  
800-962-8979

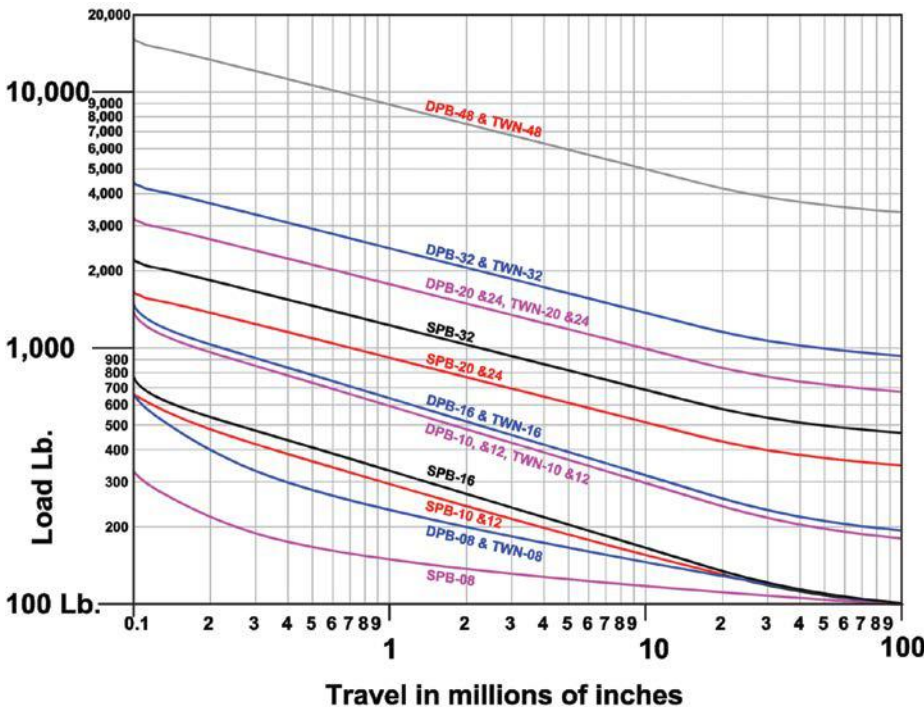

## Determining Pillow Block Size & Model

To determine the proper size Roller Pillow Block for an application, refer to the chart using the worst-case load and the required travel life. Select the Roller Pillow Block above where the lines intersect. This should be suitable for anticipated travel life and loading.

**Note:** Shock, vibration, and moments may affect the life of the pillow block.

**Note:** Chart is rated at 10% accuracy. Figures are based on a safety factor of one.

TECHNICAL

# Adjustments & Curves Roller Pillow Block Bearings

## Adjustments

Roller Pillow Blocks are factory set for Simplicity® 60 Plus® shafting. Adjustments can be made to the eccentric cam follower to either increase or decrease the shaft clearance.

Located on the same side of the Roller Pillow Block as the set screw, the eccentric cam follower is adjusted by using a stubby allen wrench while allowing a 0.002" feeler gauge to freely move between the shaft and the eccentric roller. The fixed side must remain in contact with the shaft. If care is taken not to overload the roller, then a slight pre-load is possible. Rollers should never be tightened to the point where they cannot move freely.

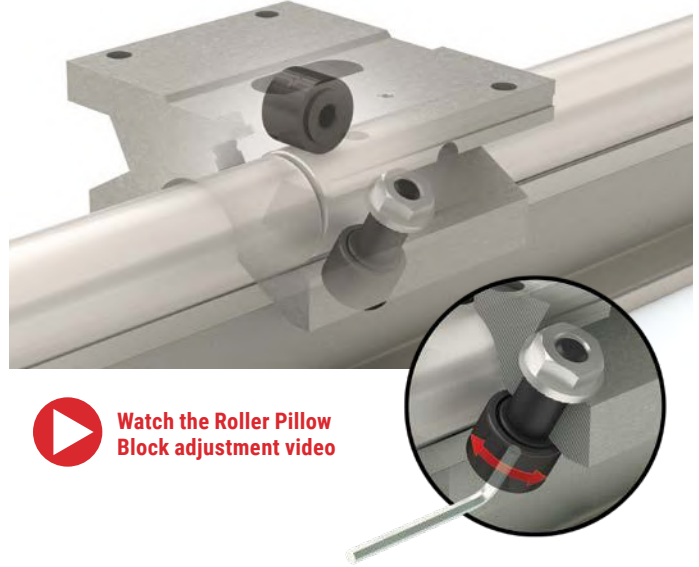

## Turning a Curve

A single Roller Pillow Block has the ability to turn a curve or run on a non-linear system. The following table lists the minimum track radius that the single Roller Pillow Block can tolerate without additional alteration.

Pillow Block Size	Minimum Shaft Radius
8	6"
10	12"
12	14"
16	18"
20	36"
24	40"
32	44"
48	52"

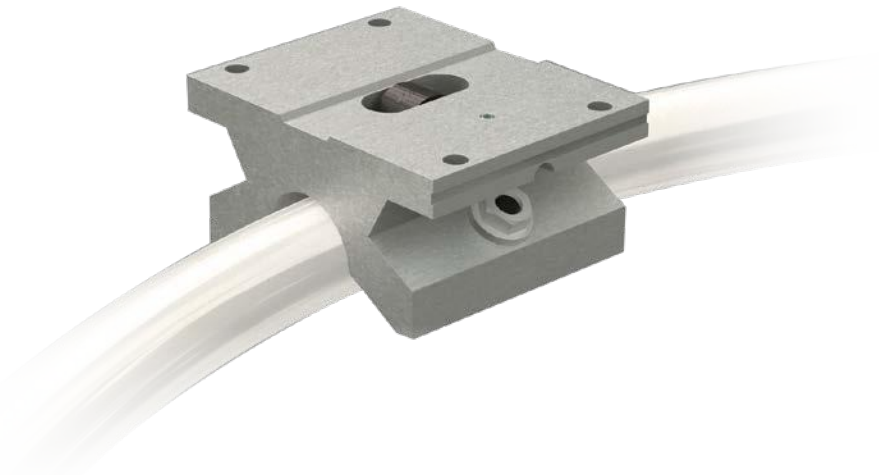

## Lubrication, Rails & Bearings

The rollers are internally lubricated for life, but the rails must always have a layer of grease. As a guideline, reapply fresh grease every 50,000 cycles.

# Cross Reference Guide Roller Pillow Block Bearings

## Cross Reference Guide

Below is a chart that cross-references our product with competitors.  
For more assistance, please consult the factory.

### Standard Linear Ball Bearings

PBC Linear	PBC Linear Sealed	Thomson	Thomson Sealed	INA	INA Sealed	NB Steel Retainer	NB Steel Retainer Sealed	NB Plast'c Retainer	NB Plast'c Retainer Sealed
IP4G-0S	IP4G	A4812		KBZ04	KBZ04PP	SW4	SW4UU	SW4G	SW4GUU
IP6G-0S	IP6G	A61014		KBZ06	KBZ06PP	SW6	SW6UU	SW6G	SW6GUU
IP8G-0S	IP8G	A81420	A81420DD	KBZ08	KBZ08PP	SW8	SW8UU	SW8G	SW8GUU
IP10G-0S	IP10G	A101824		KBZ10	KBZ10PP	SW10	SW10UU	SW10G	SW10GUU
IP12G-0S	IP12G	A122026	A122026DD	KBZ12	KBZ12PP	SW12	SW12UU	SW12G	SW12GUU
IP16G-0S	IP16G	A162536	A162536DD	KBZ16	KBZ16PP	SW16	SW16UU	SW16G	SW16GUU
IP20G-0S	IP20G	A203242		KBZ20	KBZ20PP	SW20	SW20UU	SW20G	SW20GUU
IP24G-0S	IP24G	A243848		KBZ24	KBZ24PP	SW24	SW24UU	SW24G	SW24GUU
IP32G-0S	IP32G	A324864		KBZ32	KBZ32PP	SW32	SW32UU	SW32G	SW32GUU

### Open Type Linear Ball Bearings

PBC Linear	PBC Linear Sealed	Thomson	Thomson Sealed	INA	INA Sealed	NB Steel Retainer	NB Steel Retainer Sealed	NB Plast'c Retainer	NB Plast'c Retainer Sealed
IP8G-OP-0S	IP8G-OP	OPN81420	OPN81420DD	KBZ08OP	KBZ08OPPP	SW8OP	SW8OPUU	SW8GOP	SW8GOPUU
IP10G-OP-0S	IP10G-OP	OPN101824		KBZ10OP	KBZ10OPPP	SW10OP	SW10OPUU	SW10GOP	SW10GOPUU
IP12G-OP-0S	IP12G-OP	OPN122026	OPN122026DD	KBZ12OP	KBZ12OPPP	SW12OP	SW12OPUU	SW12GOP	SW12GOPUU
IP16G-OP-0S	IP16G-OP	OPN162536	OPN162536DD	KBZ16OP	KBZ16OPPP	SW16OP	SW16OPUU	SW16GOP	SW16GOPUU
IP20G-OP-0S	IP20G-OP	OPN203242		KBZ20OP	KBZ20OPPP	SW20OP	SW20OPUU	SW20GOP	SW20GOPUU
IP24G-OP-0S	IP24G-OP	OPN243848		KBZ24OP	KBZ24OPPP	SW24OP	SW24OPUU	SW24GOP	SW24GOPUU
IP32G-OP-0S	IP32G-OP	OPN324864		KBZ32OP	KBZ32OPPP	SW32OP	SW32OPUU	SW32GOP	SW32GOPUU

### High Load Self Aligning Linear Ball Bearings

PBC Linear	Thomson	INA	NB
IPS6	SUPER6	KX6PP	TW6UU
IPS8	SUPER8	KX8PP	TW8UU
IPS10	SUPER10	KX10PP	TW10UU
IPS12	SUPER12	KX12PP	TW12UU
IPS16	SUPER16	KX16PP	TW16UU
IPS20	SUPER20	KX20PP	TW20UU
IPS24	SUPER24	KX24PP	TW24UU
IP8-OP	SUPER80PN	KX08PP	TW80PUU
IP10-OP	SUPER100PN	KX010PP	TW100PUU
IP12-OP	SUPER120PN	KX012PP	TW120PUU
IP16-OP	SUPER160PN	KX016PP	TW160PUU
IP20-OP	SUPER200PN	KX020PP	TW200PUU
IP24-OP	SUPER240PN	KX024PP	TW240PUU

PBC Linear	Thomson	INA	NB
IPPS08-GL	SPB8UU	KGX8PP	TWA8UU
IPPS10-GL	SPB10UU	KGX10PP	TWA10UU
IPPS12-GL	SPB12UU	KGX12PP	TWA12UU
IPPS16-GL	SPB16UU	KGX16PP	TWA16UU
IPPS20-GL	SPB20UU	KGX20PP	TWA20UU
IPPS24-GL	SPB24UU	KGX24PP	TWA24UU
IPPNS08-GLP	SPB80PN	KGX08PP	TWD8UU
IPPNS10-GLP	SPB100PN	KGX010PP	TWD10UU
IPPNS12-GLP	SPB120PN	KGX012PP	TWD12UU
IPPNS16-GLP	SPB160PN	KGX016PP	TWD16UU
IPPNS20-GLP	SPB200PN	KGX020PP	TWD20UU
IPPNS24-GLP	SPB240PN	KGX024PP	TWD24UU

TECHNICAL



Consult Factory • 800-962-8979



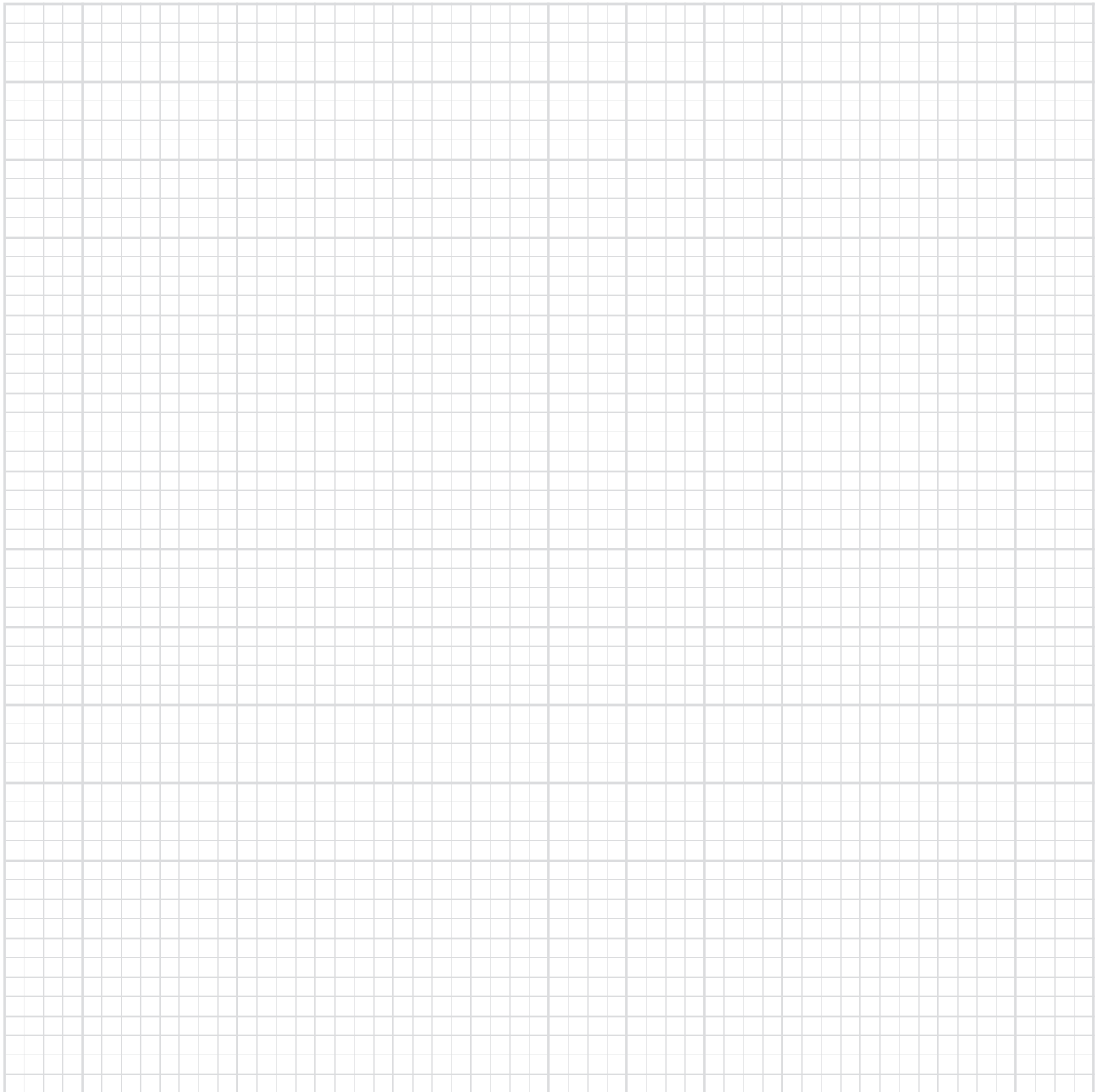



A Pacific Bearing Company

Engineering Your Linear Motion Solutions



## Global Footprint



### 📍 PBC Linear Worldwide Headquarters

6402 E. Rockton Road, Roscoe, Illinois 61073 USA

Tel: +1.815.389.5600 • Toll-Free: +1.800.962.8979

Fax: +1.815.389.5790

sales@pbclinear.com • pbclinear.com

### 📍 PBC Linear Europe GmbH European Headquarters

Bonner Straße 363, 40589 Duesseldorf, Germany

Tel: +49 211 545590 20 • Fax: +49 211 545590 39

info@pbclinear.eu • pbclinear.eu

### 📍 PBC-MOONS China Headquarters

168 Mingjia Road, Minhang District, Shanghai 201107, P.R. China

Tel: +86 21 52634688 • Fax: +86 21 52634098

info@moons.com.cn • www.moons.com.cn

## Range of Offerings



Components

Mechatronics

### Request a FREE Product Sample



Simplicity Metric FM08  
8 mm Aluminum Shaft



Simplicity Inch FL08  
1/2" Aluminum Shaft



Simplicity Inch FL08  
Stainless Steel RC 50 Shaft

[pbclinear.com/Contact-Us/Sample-Request](http://pbclinear.com/Contact-Us/Sample-Request)

### Distributed by

PBC Linear has a global network of distributors with thousands of locations worldwide.

Visit [pbclinear.com](http://pbclinear.com) to find a distributor near you.

All information within this catalog is correct at the time of printing. However, in some instances adjustments need to be made, and this may cause specific information to become outdated. For the most current version, please reference our online catalog through the resources menu at [pbclinear.com](http://pbclinear.com).

©2014 PBC Linear®, A Pacific Bearing Company • "PBC Linear" and "PBC Lineartechnik GmbH" are subsidiaries of Pacific Bearing Company ("PBC"). Specifications are subject to change without notice. It is the responsibility of the user to determine and ensure the suitability of PBC's products for a specific application. PBC's only obligation will be to repair or replace, without charge, any defective components if returned promptly. No liability is assumed beyond such replacement. Other corporate and product names, images, text and logos may be trademarks or copyrights of other companies and are used only for explanation and to the owners benefit; without intent to infringe. This document may not be reproduced, in part or whole, without the prior written authorization of PBC. Consult [pbclinear.com](http://pbclinear.com) for the latest technical updates.

LITRST-006 v42 (09-2025)