

SH. 1
OF 1

CAT NO

436.1XRLZ-18

CUSTOMER DIMENSIONS

DO NOT
SEPARATE
PRINT FROM
WORK

LOT NO

OPER

TOOLS

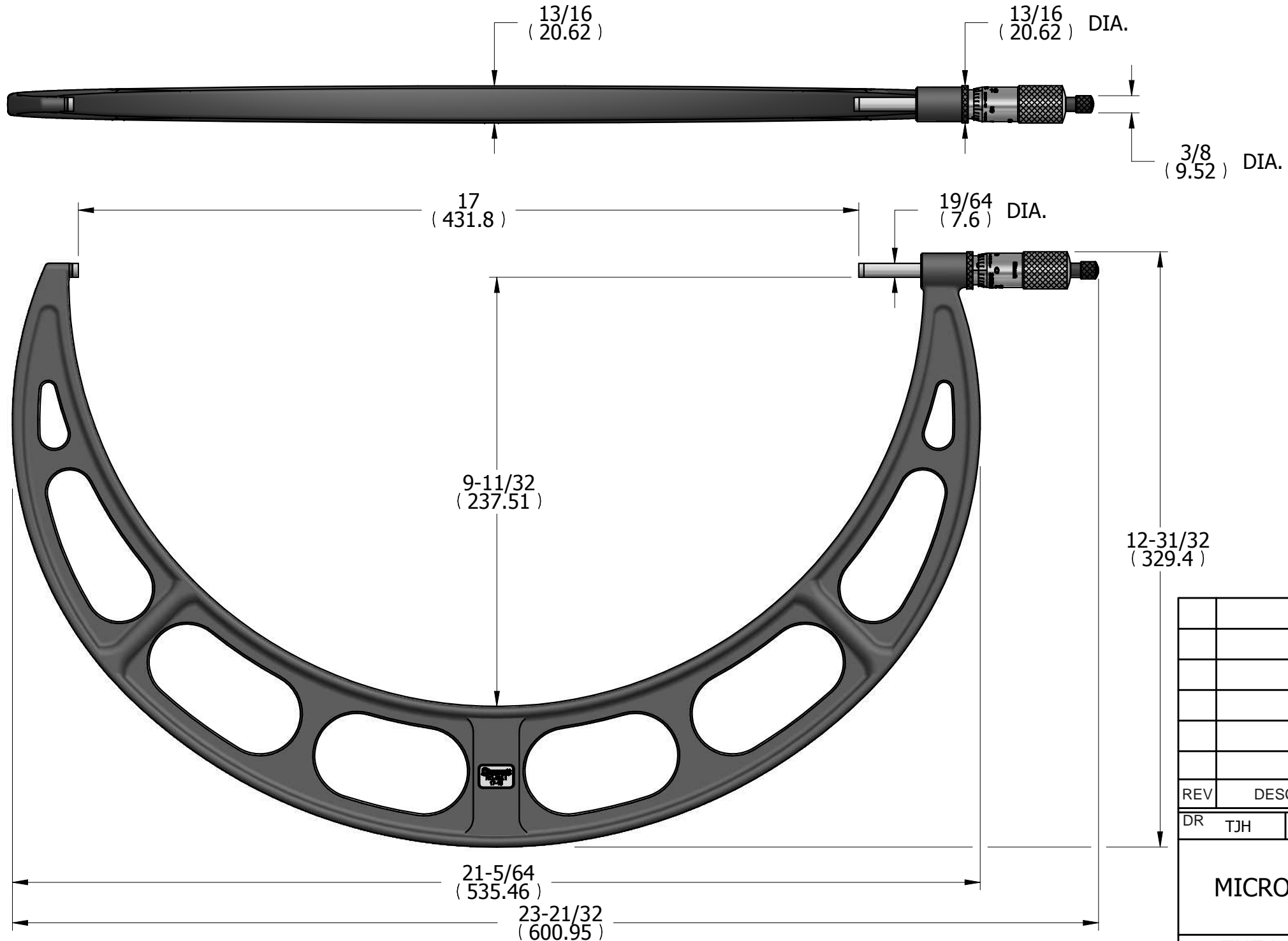

REV	DESCRIPTION	DATE	BY
DR	TJH	CHK	DATE 6/25/15

MICROMETER CALIPER

THE L.S. STARRETT CO.
ATHOL, MASS.

FRACTIONAL TOLERANCE +- 1/64 UNLESS OTHERWISE NOTED